

cannon

# Interconnect Solutions for e-mobility

IEC, SAE and GB/T



**ITT**

ENGINEERED FOR LIFE

# We Connect

## The future of e-mobility

Drawing upon 100 years of interconnect excellence and nearly a decade of innovation in the Electric Vehicle industry, ITT represents a committed partner to today's e-mobility industry, bringing connection solutions to the market that are truly Engineered for Life.

## Global solutions for the EV industry

### The ITT difference

- Proven application expertise
- Global capabilities & local support
- Unrivalled customization expertise
- A committed innovator & business partner

### About ITT

ITT is a diversified leading manufacturer of highly engineered critical components and customized technology solutions for the energy, transportation and industrial markets. Building on its heritage of innovation, ITT partners with its customers to deliver enduring solutions to the key industries that underpin our modern way of life. Founded in 1920, ITT is headquartered in White Plains, N.Y., with employees in more than 35 countries and sales in a total of approximately 125 countries. For more information visit [www.itt.com](http://www.itt.com)



# IEC, SAE and GB/T e-mobility Interconnect Solutions

ITT's class leading UL and CE certified connectors, plugs, inlets, outlets and accessories offer recognized, trusted and proven charging solutions for today's e-mobility markets. Built in accordance with all key regional standards - IEC 62196 for Europe, SAE J1772 for the Americas and Japan and GB/T 20234 for China they provide a truly global portfolio.

ITT offers a fully comprehensive range of AC charging options— with an industry leading amperage range from 10A to 80A, single and triple phase variants, low contact resistance and a minimum of 10k mating cycles. In addition to off the shelf solutions our EV offering is fully customizable to meet specific requirements and we are able to offer variants on colors, harnesses and terminals.

By using common coupler connector/plug elements such as an ergonomically designed handle, robust contact system, innovative wire positioners and strain relief system ITT is able to serve global industry players with a consistent, recognizable look and feel to support their own product, user and brand experience.



## Key features

- Cable options certified and approved to regional requirements
- Sealing to meet and exceed specifications
- Up to 80A AC Charging option
- Low contact resistance
- Minimum 10k mating cycles
- Connector and plug strain relief provides protection from cable overstressing

## Applications

- Home EV Charging Units
- Public Charging Stations
- Roadside Assistance Trucks
- Fleet Trucks
- EV Mass Transit Vehicles
- Electric Watercraft
- Passenger Vehicles
- Electric Motorcycles
- Electric Agriculture Vehicles

## An e-mobility leader

- A truly global product portfolio
- Extensive customization options
- A track record of EV innovation
- A pioneer in DC fast charging technology

## The Gen 2+ Contact System

ITT's new Gen2+ contact system utilizes a state of the art canted coiled spring design that delivers extended lifetime usage and minimizes mechanical stress, miss alignment and power loss.





## IEC electric vehicle charging solutions

ITT's IEC e-mobility solutions are built in accordance with IEC 62196-1 and 62196-2 standards for single and three phase charging systems.

IEC performance data	
Temperature Range	-30°C to +50°C
Durability	10,000 mating cycles min
Sealing Requirements	IP 44 min per IEC 61851-1 and tested in accordance with IEC 60525
Certifications Connector	CE, ETL, IEC 62196-1 and IEC 62196-2
Certifications Cable	DIN EN 50620

### Key Features

- Drain holes at the bottom of the coupler connector/plug – eliminates latch freezing and includes protective shield from small diameter metal penetration to the wiring.
- Textured coupler connector/plug handle – provides enhanced grip while in use.
- Optional mating face protection – lanyard dust caps options for coupler connector/plug and spring cap options for inlets provide additional protection when connectors are not in use.



## ECIER Outlet

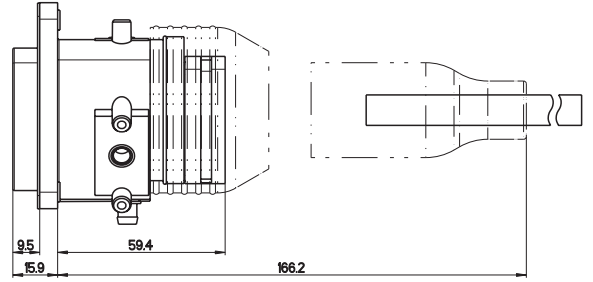
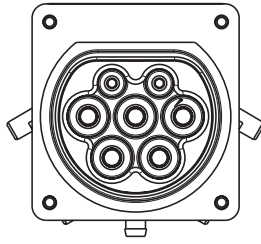

### How to order

**ECIER 20 2 1 -017 S 2 A 1 A 0 A 0 -001**

- Connector Series & Style
- Current Rating (Cable size)
- Cable Rating
- Powering System (Connector Voltage Rating)
- Cable Length (3 Digits)
- Sealing Method
- Compression Limiter / Metal Inserts in Flange Holes
- Dust Cap / Spring Cap
- Drain Spout
- Locking Device
- Rubber Boot
- Mounting Hole Pattern
- Flange Gasket
- Modification Code - If Applicable (3 digits)

## Explanation

### Connector Series & style

**ECIER** - EVC IEC 62196 Type 2 Connector EVSE  
Rear mount inlet

### Current Rating (Cable size)

20A, 32A, 63A

### Cable Rating

2 - Level 2

### Powering System (Connector Voltage Rating)

- 1 - Single phase (240VAC)
- 3 - Three phase (480VAC)

### Cable Length (3 Digits)

XXX - Length in 0.1m\*XXX (017 = 1.7m)

### Sealing Method

S - Sealed

### Compression Limiter / Metal Inserts in Flange Holes

- 0 - Without compression limiter/inserts
- 1 - Compression limiter (front mounting)
- 2 - Compression limiter with threaded inserts M4 (front mounting)

### Dust Cap / Spring Cap

- A - No dust cap supplied
- C - Dust cap stainless steel lanyard (155mm)
- D - Dust cap stainless steel lanyard (125mm)
- E - Dust cap PA lanyard (155mm)
- K - With mounting ring thin (to be used with mounting hole pattern "B" only) (metal inserts M4)
- L - With mounting ring (to be used with mounting hole pattern "B" only) (metal inserts M4)
- M - Dust cap PA lanyard, ring terminal (125mm)
- N - Dust cap PA lanyard (125mm)

### Drain Spout

- 0 - Without drain spout
- 1 - With drain spout, without tube
- 2 - With drain spout with tube; 1m long
- 3 - With drain spout with tube, 2m long

### Locking Device

- A - No locking device
- B - Motorized switch assembly (No male connector supplied for locking).
- C - Motorized switch assembly including connector & 300mm cable

- D - Motorized switch assembly including connector & 300mm cable & socket contacts on single wires
- E - Solenoid 12VDC assembly (cable length 250mm)
- F - Solenoid 24VDC assembly (cable length 250mm)
- G - Solenoid 12VDC assembly (same as cable length)
- H - Solenoid 24VDC assembly (same as cable length)

### Rubber Boot

0 - No rubber boot supplied

### Mounting Hole Pattern

- B - 58x61mm
- C - 52x52mm

### Flange Gasket

- 0 - No flange gasket supplied.
- 1 - With flange gasket

**Modification Code - If Applicable (3 digits)**  
001 to 999 - For customer specific modification

Dimensions shown in mm  
Specifications and dimensions subject to change

## ECCE Plug

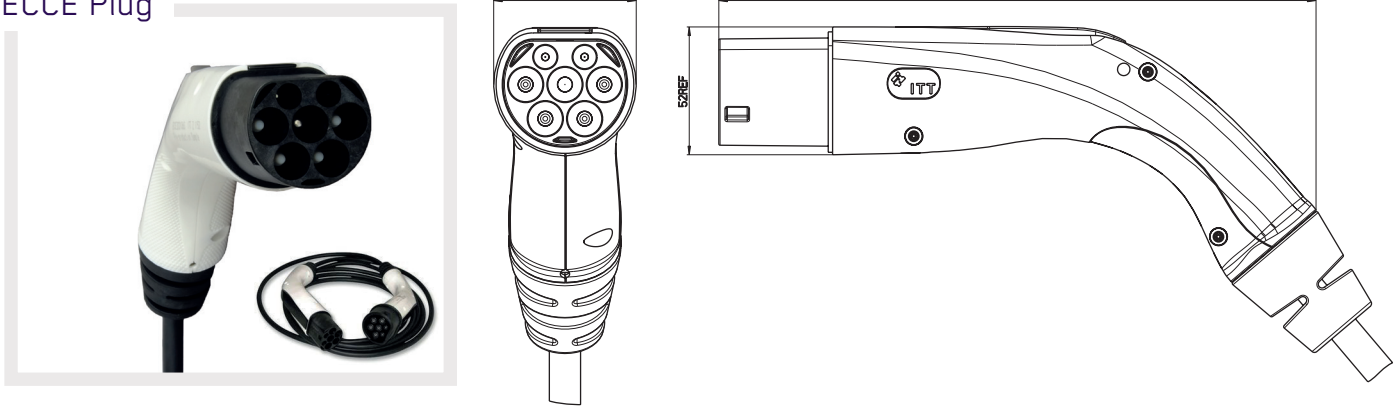

### How to order

ECCE 20 2 1 -017 S 0 A -ECCV 0 A -001

- Connector Series & Style
- Current Rating (Cable size)
- Cable Rating
- Powering System (Connector Voltage Rating)
- Cable Length (3 Digits)
- Sealing Method
- Direction of Cable Strain Relief
- Dust Cap
- Modification Code (4 Letters)
- Direction of Cable Outlet
- Dust Cap
- Modification Code - If Applicable (3 digits)

## Explanation

### Connector Series & style

**ECCE** - EVC IEC 62196 Type 2 mode 3 connection cable EVSE coupler to vehicle coupler

### Current Rating (Cable size)

20A, 32A, 63A

### Cable Rating

2 - Level 2

### Powering System (Connector Voltage Rating)

1 - Single phase (240VAC)  
3 - Three phase (480VAC)

### Cable Length (3 Digits)

XXX - Length in 0.1m\*XXX (017 = 1.7m)

### Sealing Method

S - Sealed

### Direction of strain relief ECCE

0 - Straight cable strain relief  
1 - Angled cable strain relief (90° Downwards) (not for 63A)

### Dust Cap

A - No dust cap supplied  
B - Dust cap rubber lanyard (187mm)  
C - Dust cap stainless steel lanyard (155mm)  
D - Dust cap stainless steel lanyard (125mm)  
E - Dust cap PA lanyard (155mm)  
F - Dust cap PA lanyard (125mm)

### Modification Code (4 Letters)

**ECCV** - Connection cable IEC type 2 connector on 2-end  
**GBCV** - Connection cable GBCV connector on 2-end  
**EJCV** - Connection cable IEC type 1 connector on 2-end (same connector as J2CE) only 1 phase existing

### Direction of strain relief of second connector

0 - Straight cable strain relief  
1 - Angled cable strain relief (90° Downwards) (not for 63A)

### Dust Cap

A - No dust cap supplied  
B - Dust cap rubber lanyard (only for GBCV at second end)  
C - Dust cap stainless steel lanyard (155mm)  
D - Dust cap stainless steel lanyard (125mm)  
E - Dust cap PA lanyard (155mm)  
F - Dust cap PA lanyard (125mm)

### Modification Code - If Applicable (3 digits)

001 to 999 - For customer specific modification

## ECCV Connector

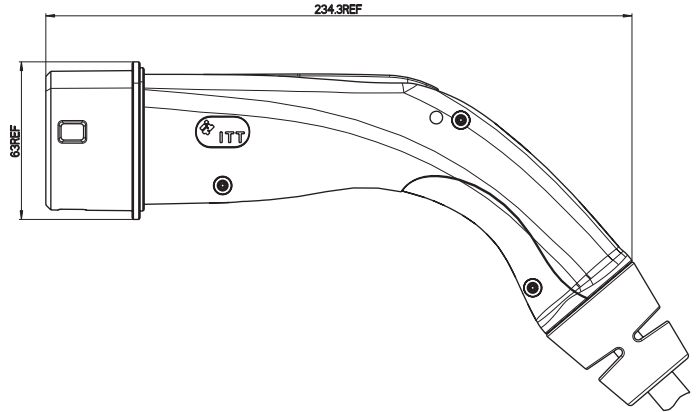
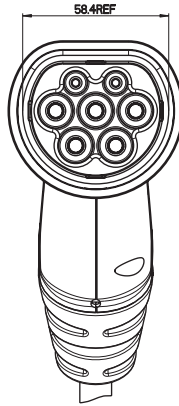

### How to order

ECCV 20 2 1 -017 S 0 A -001

Connector Series & Style

Current Rating (Cable size)

Cable Rating

Powering System (Connector Voltage Rating)

Cable Length (3 Digits)

Sealing Method

Direction of Cable Strain Relief

Dust Cap

Modification Code - If Applicable (3 digits)

### Explanation

#### Connector Series & style

**ECCV** - EVC IEC 62196 Type 2 Connector vehicle coupler

#### Current Rating (Cable size)

20A, 32A, 63A

#### Cable Rating

2 - Level 2

#### Powering System (Connector Voltage Rating)

1 - Single phase (240VAC)

3 - Three phase (480VAC)

#### Cable Length (3 Digits)

**XXX** - Length in 0.1m\*XXX (017 = 1.7m)

#### Sealing Method

S - Sealed

#### Direction of Cable Strain Relief

0 - Straight cable strain relief

1 - Angled cable strain relief (90° Downwards)

#### Dust Cap

**A** - No dust cap supplied

**C** - Dust cap stainless steel lanyard (155mm).

**D** - Dust cap stainless steel lanyard (125mm)

**E** - Dust cap PA lanyard (155mm)

**F** - Dust cap PA lanyard (125mm)

#### Modification Code - If Applicable (3 digits)

**001 to 999** - For customer specific modification

Dimensions shown in mm

Specifications and dimensions subject to change



## ECIV Inlet

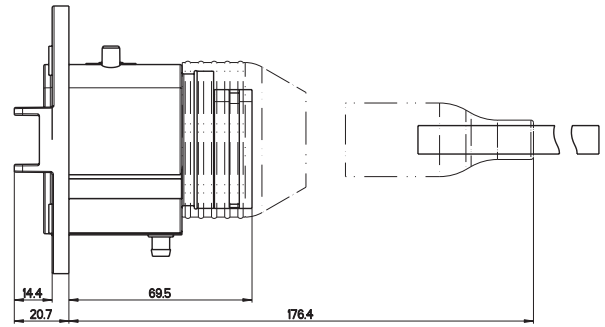
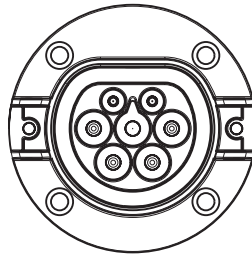

### How to order

ECIV 20 2 1 -017 S 1 A 1 A 0 A 0 -001

Connector Series & Style

Current Rating (Cable size)

Cable Rating

Powering System (Connector Voltage Rating)

Cable Length (3 Digits)

Sealing Method

Compression Limiter / Metal Inserts in Flange Holes

Dust Cap / Spring Cap

Drain Spout

Locking Device

Rubber Boot

Mounting Hole Pattern

Flange Gasket

Modification Code - If Applicable (3 digits)

## Explanation

### Connector Series & style

ECIV - EVC IEC 62196 Type 2 Connector vehicle inlet

### Current Rating (Cable size)

20A, 32A, 63A

### Cable Rating

2 - Level 2

### Powering System (Connector Voltage Rating)

1 - Single phase (240VAC)

3 - Three phase (480VAC)

### Cable Length (3 Digits)

XXX - Length in 0.1m\*XXX (017 = 1.7m)

### Sealing Method

S - Sealed

### Compression Limiter / Metal Inserts in Flange Holes

0 - Without compression limiter/inserts

1 - Compression limiter (front mounting)

2 - Compression limiter with threaded inserts M4 (front mounting)

3 - Compression limiter with threaded inserts M5 (front mounting)

### Dust Cap / Spring Cap

A - No dust cap supplied

C - Dust cap stainless steel lanyard (155mm)

D - Dust cap stainless steel lanyard (125mm)

E - Dust cap PA lanyard (155mm)

G - With spring cap (Opening to left)

H - With spring cap (Opening to the right)

M - Dust Cap PA Lanyard, ring terminal (125mm)

N - Dust cap PA lanyard (125mm)

### Drain Spout

0 - Without drain spout.

1 - With drain spout, without tube

2 - With drain spout with tube; 1m long

3 - With drain spout with tube, 2m long

### Locking Device

A - No locking device

B - Motorized switch assembly

(No male connector supplied for locking device)

C - Motorized switch assembly including connector and 300mm cable

D - Motorized switch assembly including connector and 300mm cable & socket contacts on single wires

### Rubber Boot

0 - No rubber boot supplied

### Mounting Hole Pattern

A - Standard pattern

### Flange Gasket

0 - No flange gasket supplied

### Modification Code - If Applicable (3 digits)

001 to 999 - For customer specific modification

## EJCV Connector

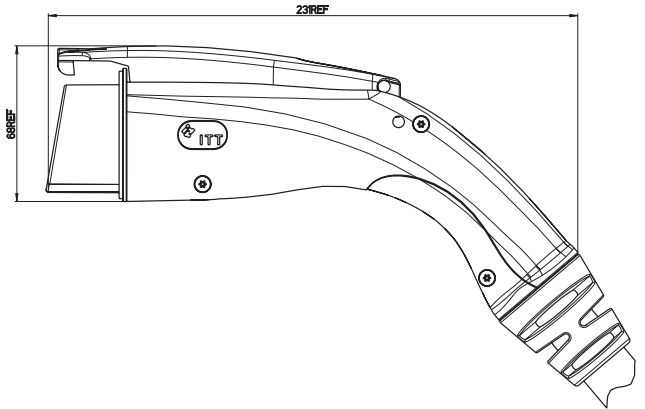
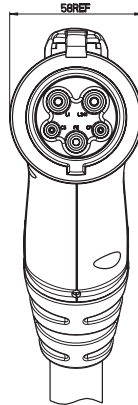

### How to order

EJCV 20 2 1 -017 S 0 A -001

Connector Series & Style

Current Rating (Cable size)

Cable Rating

Powering System (Connector Voltage Rating)

Cable Length (3 Digits)

Sealing Method

Direction of Cable Strain Relief

Dust Cap

Modification Code - If Applicable (3 digits)

### Explanation

#### Connector Series & style

**EJCV** - EVC IEC 62196 Type 1 Connector vehicle coupler

#### Current Rating (Cable size)

20A, 32A

#### Cable Rating

2 - Level 2

#### Powering System (Connector Voltage Rating)

1 - Single phase (240VAC)

#### Cable Length (3 Digits)

**XXX** - Length in 0.1m\*XXX (017 = 1.7m)

#### Sealing Method

S - Sealed

#### Direction of Cable Strain Relief

0 - Straight cable strain relief

#### Dust Cap

A - No dust cap supplied

C - Dust cap stainless steel lanyard (155mm)

D - Dust cap stainless steel lanyard (125mm)

E - Dust cap PA lanyard (155mm)

F - Dust cap PA lanyard (125mm)

#### Modification Code - If Applicable (3 digits)

001 to 999 - For customer specific modification

Dimensions shown in mm

Specifications and dimensions subject to change

## EJIV Inlet

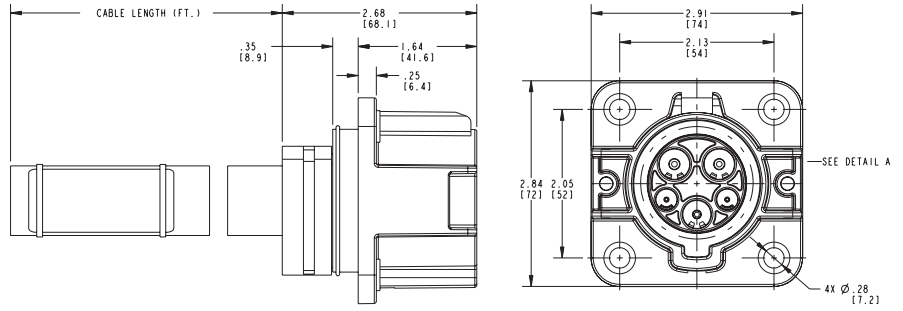

### How to order

**EJIV 20 2 1 -017 S 0 A 0 A 0 A 0 -001**

- Connector Series & Style
- Current Rating (Cable size)
- Cable Rating
- Powering System (Connector Voltage Rating)
- Cable Length (3 Digits)
- Sealing Method
- Compression Limiter / Metal Inserts in Flange Holes
- Dust Cap / Spring Cap
- Drain Spout
- Locking Device
- Rubber Boot
- Mounting Hole Pattern
- Flange Gasket
- Modification Code - If Applicable (3 digits)

### Explanation

#### Connector Series & style

**EJIV** - EVC IEC 62196 Type 1 Connector vehicle inlet

#### Current Rating (Cable size)

20A, 32A

#### Cable Rating

2 - Level 2

#### Powering System (Connector Voltage Rating)

1 - Single phase (240VAC)

#### Cable Length (3 Digits)

XXX - Length in 0.1m\*XXX (017 = 1.7m)

#### Sealing Method

S - Sealed

#### Compression Limiter / Metal Inserts in Flange Holes

0 - Without compression limiter/inserts

1 - Compression limiter (front mounting)

3 - Compression limiter with threaded inserts M5 (front mounting)

#### Dust Cap / Spring Cap

A - No dust cap supplied

G - With spring cap (Opening to left)

H - With spring cap (Opening to right)

#### Drain Spout

0 - Without drain spout

#### Locking Device

A - No locking device

#### Rubber Boot

0 - No rubber boot supplied

#### Mounting Hole Pattern

A - Standard pattern

#### Flange Gasket

0 - No flange gasket supplied

#### Modification Code - If Applicable (3 digits)

001 to 999 - For customer specific modification



# SAE J1772 electric vehicle charging solutions

ITT's SAE J1772 e-mobility solutions are built in accordance with SAE J1772 standard for AC Level 1 and Level 2 charging systems.

J1772 performance data	
Temperature Range	-30°C to +50°C
Durability	10,000 mating cycles min
Sealing Requirements	Meets UL50, Type 3R/3S
Certifications Connector	UL File E330790, CE, PSE-JET
Certifications Cable	UL62 or JET

## Key Features

- Drain holes at the bottom of the coupler connector/plug – eliminates latch freezing and includes protective shield from small diameter metal penetration to the wiring.
- Textured coupler connector/plug handle – provides enhanced grip while in use.
- Optional mating face protection – lanyard dust caps options for coupler connector/plug and spring cap options for inlets provide additional protection when connectors are not in use.

## J2CE Connector

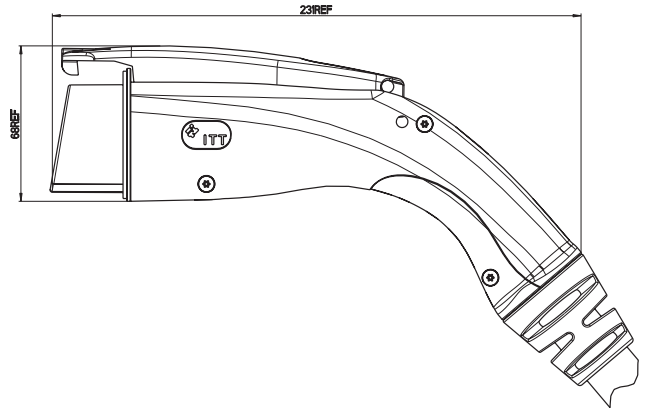
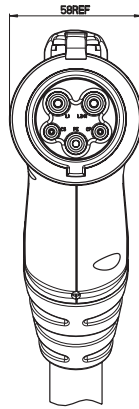

## How to order

J2CE 16 1 1 -17 S 0 A -001

- Connector Series & Style
- Current Rating (Cable size)
- Cable Rating
- Powering System (Connector Voltage Rating)
- Cable Length (2 Digits)
- Sealing Method
- Direction of Cable Strain Relief
- Dust Cap
- Modification Code - If Applicable (3 digits)

## Explanation

- Connector Series & style**  
**J2CE** - EVC SAE-J1772 Connector vehicle coupler
- Current Rating (Cable size)**  
**16** - 16A (level 1 only)  
**20** - 20A  
**30** - 30A (level 2 only)  
**40** - 40A (level 2 only)  
**75** - 75A (level 2 only)  
**80** - 80A (level 2 only)
- Cable Rating**  
**1** - Level 1  
**2** - Level 2

- Powering System (Connector Voltage Rating)**  
**1** - Single phase (120VAC for level 1, 240VAC for level 2)
- Cable Length (2 digits)**  
**XX** - Length in ft. (17 = 17ft.)
- Sealing Method**  
**S** - Sealed
- Direction of Cable Strain Relief**  
**0** - Straight cable strain relief

- Dust Cap**  
**A** - No dust cap supplied  
**C** - Dust cap stainless steel lanyard (6.1in)  
**D** - Dust cap stainless steel lanyard (4.9in)  
**E** - Dust cap PA lanyard (6.1in)  
**F** - Dust cap PA lanyard (4.9in)
- Modification Code - If Applicable (3 digits)**  
**001 to 999** - For customer specific modification

Dimensions shown in mm  
 Specifications and dimensions subject to change

## J2IV Inlet

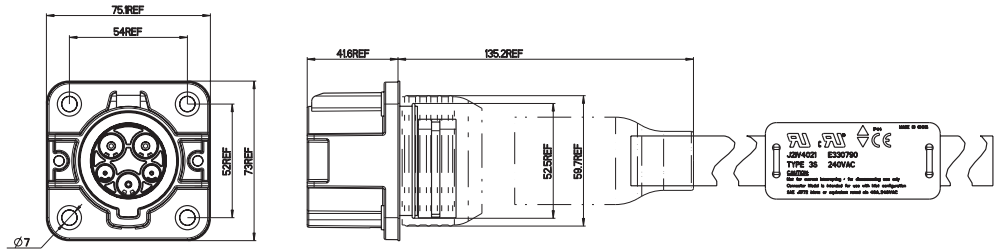

### How to order

J2IV 20 2 1 -17 S 1 A 0 A 0 A 0 -001

Connector Series & Style

Current Rating (Cable size)

Cable Rating

Powering System (Connector Voltage Rating)

Cable Length (2 Digits)

Sealing Method

Compression Limiter / Metal Inserts in Flange Holes

Dust Cap / Spring Cap

Drain Spout

Locking Device

Rubber Boot

Mounting Hole Pattern

Flange Gasket

Modification Code - If Applicable (3 digits)

## Explanation

### Connector Series & style

J2IV - EVC SAE-J1772 Connector vehicle inlet

### Current Rating (Cable size)

20 - 20A

40 - 40A (level 2 only)

75 - 75A (level 2 only)

80 - 80A (level 2 only)

### Cable Rating

1 - Level 1

2 - Level 2

### Powering System (Connector Voltage Rating)

1 - Single phase (120V AC for level 1, 240VAC for levels 2)

### Cable Length (2 Digits)

XX - Length in ft. (17 = 17ft)

### Sealing Method

S - Sealed

### Compression Limiter / Metal Inserts in Flange Holes

0 - Without compression limiter/inserts

1 - Compression limiter (front mounting)

3 - Compression limiter with threaded inserts M5 (front mounting)

### Dust Cap / Spring Cap

A - No dust cap supplied.

G - With spring cap (Opening to left)

H - With spring cap (Opening to right)

### Drain Spout

0 - Without drain spout

### Locking Device

A - No locking device

### Rubber Boot

0 - No rubber boot supplied

### Mounting Hole Pattern

A - Standard pattern

### Flange Gasket

0 - No flange gasket supplied

### Modification Code - If Applicable (3 digits)

001 to 999 - For customer specific modification



## GB/T electric vehicle charging solutions

ITT's GB e-mobility solutions are built in accordance with GB-T 20234 standards for charging systems.

GB performance data	
Temperature Range	-30°C to +50°C
Durability	10,000 mating cycles min
Sealing Requirements	IP54/IP55
Certifications Connector	CQC 13029087619
Certifications Cable	CQC 1103 or 1104

### Key Features

- Drain holes at the bottom of the coupler connector/plug – eliminates latch freezing and includes protective shield from small diameter metal penetration to the wiring.
- Textured coupler connector/plug handle – provides enhanced grip while in use.
- Optional mating face protection – lanyard dust caps options for coupler connector/plug and spring cap options for inlets provide additional protection when connectors are not in use.



## GBIE Outlet

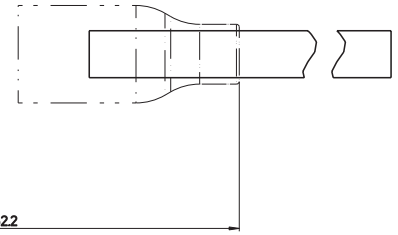
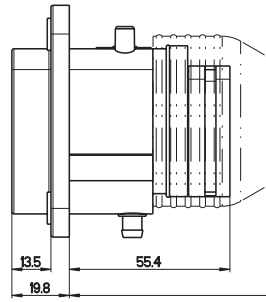
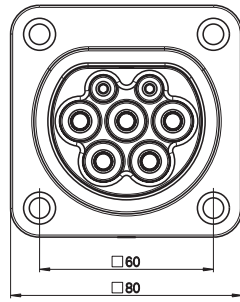

### How to order

**GBIE 16 2 1 -017 S 0 A 1 A 0 A 0 -001**

Connector Series & style

Current Rating (Cable size)

Cable Rating

Powering System (Connector Voltage Rating)

Cable Length (3 Digits)

Sealing Method

Compression Limiter / Metal Inserts in Flange Holes

Dust Cap / Spring Cap

Drain Spout

Locking Device

Rubber Boot

Mounting Hole Pattern

Flange Gasket

Modification Code - If Applicable (3 digits)

## Explanation

### Connector Series & style

**GBIE** - EVC GB/T 20234 Connector EVSE inlet

### Current Rating (Cable size)

**10** - 10A (1 phase only)

**16** - 16A

**32** - 32A

### Cable Rating

**2** - Level 2

### Powering System (Connector Voltage Rating)

**1** - Single phase (250VAC)

**3** - Three phase (440VAC)

### Cable Length (3 Digits)

**XXX** - Length in 0.1m\*XXX (017 = 1.7m)

### Sealing Method

**S** - Sealed

### Compression Limiter / Metal Inserts in Flange Holes

**0** - Without compression limiter/inserts

**1** - Compression limiter (front mounting)

**3** - Compression limiter with threaded inserts M5 (front mounting)

### Dust Cap / Spring Cap

**A** - No dust cap supplied

**C** - Dust cap stainless steel lanyard (155mm)

**D** - Dust cap stainless steel lanyard (125mm)

**E** - Dust cap PA lanyard (155mm)

**F** - Dust cap without lanyard, Sealing on OD

**M** - Dust Cap PA Lanyard, ring terminal (125mm)

**N** - Dust cap PA lanyard (125mm)

### Drain Spout

**0** - Without drain spout

**1** - With drain spout without tube

**2** - With drain spout with tube; 1m long

**3** - With drain spout with tube, 2m long

### Locking Device

**A** - No locking device

**B** - Motorized switch assembly (No male connector supplied for locking device).

**C** - Motorized switch assembly including connector & 300mm cable

**D** - Motorized switch assembly including connector & 300mm cable & socket contacts on single wires

**E** - Solenoid 12VDC assembly (cable length 250mm)

**F** - Solenoid 24VDC assembly (cable length 250mm)

**G** - Solenoid 12VDC assembly (same as cable length)

**H** - Solenoid 24VDC assembly (same as cable length)

### Rubber Boot

**0** - No rubber boot supplied

### Mounting Hole Pattern

**A** - Standard pattern

### Flange Gasket

**0** - No flange gasket supplied

### Modification Code - If Applicable (3 digits)

**001 to 999** - For customer specific modification

## GBCE Plug

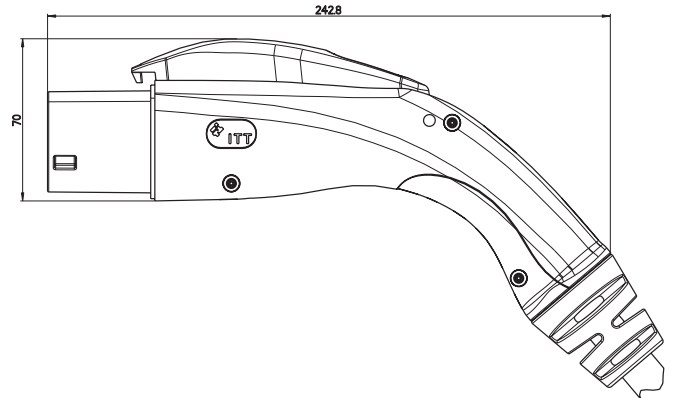
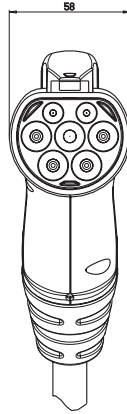

### How to order

**GBCE 16 2 1 -017 S 0 A -ECCV 0 A -001**

Connector Series & Style

Current Rating (Cable size)

Cable Rating

Powering System (Connector Voltage Rating)

Cable Length (3 Digits)

Sealing Method

Direction of Cable Strain Relief

Dust Cap

Modification Code for mode 3 combination (4 Letters)

Direction of Cable Strain Relief

Dust Cap

Modification Code - If Applicable (3 digits)

## Explanation

### Connector Series & style

**GBCE** - EVC GB/T 20234 MODE 3 connection cable  
EVSE coupler to vehicle coupler

### Current Rating (Cable size)

**10** - 10A (1 phase only)

**16** - 16A

**32** - 32A

### Cable Rating

**2** - Level 2

### Power System (Connector Voltage Rating)

**1** - Single phase (250VAC)

**3** - Three phase (440VAC)

### Cable Length (3 Digits)

**XXX** - Length in 0.1m\*XXX (017 = 1.7m)

### Sealing Method

**S** - Sealed

### Direction of Cable Strain Relief

**0** - Straight cable strain relief

### Dust Cap

**A** - No dust cap supplied

**B** - Dust cap rubber lanyard

**C** - Dust cap stainless steel lanyard (155mm)

**D** - Dust cap stainless steel lanyard (125mm)

**E** - Dust cap PA lanyard (155mm)

**F** - Dust cap PA lanyard (125mm)

### Modification Code for mode 3 combination (4 Letters)

**ECCV** - Connection cable IEC type 2 connector on 2-end

**GBCV** - Connection cable GBCV connector on 2-end

**EJCV** - Connection cable IEC type 1 connector on 2-end  
(same connector as J2CE)

**J2CE** - Connection cable SAE-J1772 connector 2-end  
(same connector as EJCV)

### Direction of Cable Strain Relief

**0** - Straight cable strain relief

### Dust Cap

**A** - No dust cap supplied

**B** - Dust cap rubber lanyard

**C** - Dust cap stainless steel lanyard (155mm)

**D** - Dust cap stainless steel lanyard (125mm)

**E** - Dust cap PA lanyard (155mm)

**F** - Dust cap PA lanyard (125mm)

### Modification Code - If Applicable (3 digits)

**001 to 999** - For customer specific modification

Dimensions shown in mm

Specifications and dimensions subject to change

## GBCV Connector

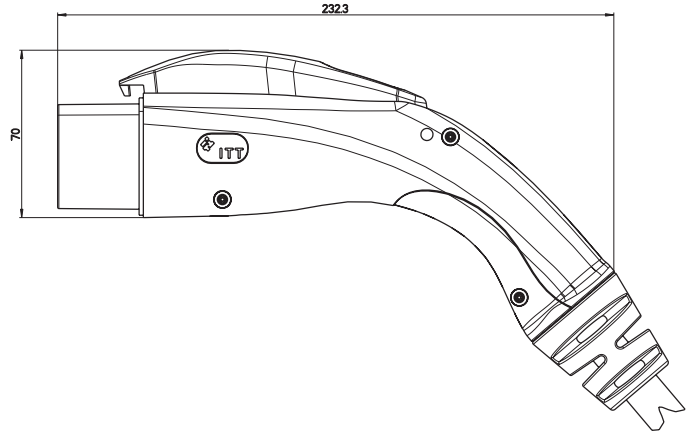
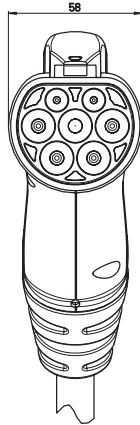

### How to order

**GBCV 16 2 1 -017 S 0 A -001**

Connector Series & Style

Current Rating (Cable size)

Cable Rating

Powering System (Connector Voltage Rating)

Cable Length (3 Digits)

Sealing Method

Direction of Cable Strain Relief

Dust Cap

Modification Code - If Applicable (3 digits)

## Explanation

### Connector Series & style

**GBCV** - EVC GB/T 20234 Connector vehicle coupler

### Current Rating (Cable size)

**10** - 10A (1 phase only)

**16** - 16A

**32** - 32A

### Cable Rating

**2** - Level 2

### Powering System (Connector Voltage Rating)

**1** - Single phase (250VAC)

**3** - Three phase (440VAC)

### Cable Length (3 Digits)

**XXX** - Length in 0.1m\*XXX (017 = 1.7m)

### Sealing Method

**S** - Sealed

### Direction of Cable Strain Relief

**0** - Straight cable strain relief

### Dust Cap

**A** - No dust cap supplied

**B** - Dust cap rubber lanyard

**C** - Dust cap stainless steel lanyard (155mm)

**D** - Dust cap stainless steel lanyard (125mm)

**E** - Dust cap PA lanyard (155mm)

**F** - Dust cap PA lanyard (125mm)

### Modification Code - If Applicable (3 digits)

**001 to 999** - For customer specific modification



## GBIV Inlet

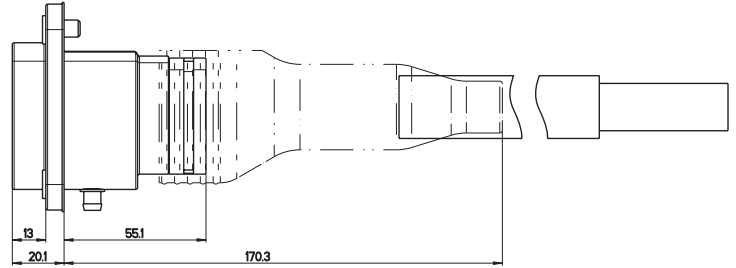
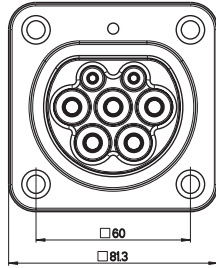

### How to order

**GBIV 16 2 1 -017 S 0 A 1 A 0 A 0 -001**

Connector Series & Style

Current Rating (Cable size)

Cable Rating

Powering System (Connector Voltage Rating)

Cable Length (3 Digits)

Sealing Method

Compression Limiter / Metal Inserts in Flange Holes

Dust Cap / Spring Cap

Drain Spout

Locking Device

Rubber Boot

Mounting Hole Pattern

Flange Gasket

Modification Code - If Applicable (3 digits)

## Explanation

### Connector Series & style

**GBIV** - EVC GB/T 20234 Connector vehicle inlet

### Current Rating (Cable size)

**10** - 10A (1 phase only)

**16** - 16A

**32** - 32A

### Cable Rating

**2** - Level 2

### Powering System (Connector Voltage Rating)

**1** - Single phase (250VAC)

**3** - Three phase (440VAC)

### Cable Length (3 Digits)

**XXX** - Length in 0.1m\*XXX (017 = 1.7m)

### Sealing Method

**S** - Sealed

### Compression Limiter / Metal Inserts in Flange Holes

**0** - Without compression limiter/inserts

**1** - Compression limiter (front mounting)

**3** - Compression limiter with threaded inserts M5 (front mounting)

### Dust Cap / Spring Cap

**A** - No dust cap supplied

**C** - Dust cap stainless steel lanyard (155mm)

**D** - Dust cap stainless steel lanyard (125mm)

**E** - Dust cap PA lanyard (155mm)

**F** - Dust cap without lanyard for OD

**M** - Dust Cap PA Lanyard, ring terminal (125mm)

**N** - Dust cap PA lanyard (125mm)

### Drain Spout

**0** - Without drain spout

**1** - With drain spout without tube

**2** - With drain spout with tube; 1m long

**3** - With drain spout with tube, 2m long

### Locking Device

**A** - No locking device

**B** - Motorized switch assembly (No male connector supplied for locking device)

**C** - Motorized switch assembly including connector & 300mm cable

**D** - Motorized switch assembly including connector & 300mm cable & socket contacts on single wires

### Rubber Boot

**0** - No rubber boot supplied

### Mounting Hole Pattern

**A** - Standard pattern

### Flange Gasket

**0** - No flange gasket supplied

**1** - With flange gasket

### Modification Code - If Applicable (3 digits)

**001 to 999** - For customer specific modification

Dimensions shown in mm

Specifications and dimensions subject to change

# EV wiring plans

## ECIER/ECIV/GBIE/GBIV

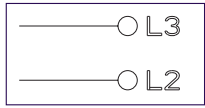

L2 and L3 for 3 phase connectors only

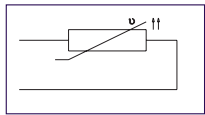
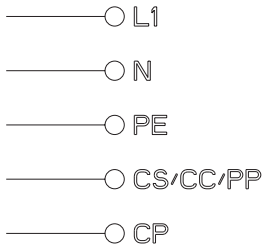

Temperature sensor  
GBIE/GBIV 32A and 63A only

## ECCE/ECCV

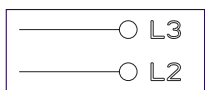

L2 and L3 for 3 phase connectors only

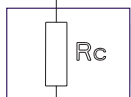
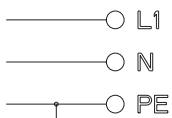

Current Ratings	Rc
20A	680Ω/0.5W
32A	220Ω/0.5W
63A	100Ω/0.5W

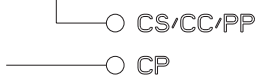

## J2IV/EJIV

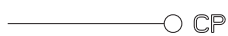
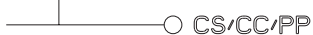
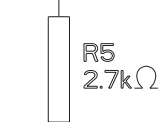
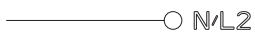

## GBCE

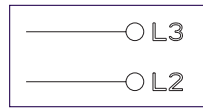

L2 and L3 for 3 phase connectors only

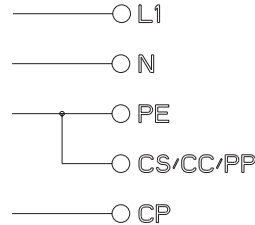

## GBCV/J2CE/EJCV

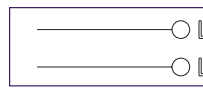

L2 and L3 for 3 phase connectors GBCV only

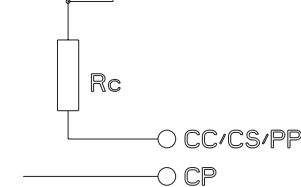
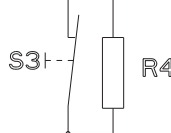
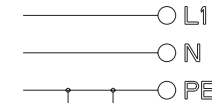

Current Ratings GBCV	R4	Rc
10A	1.8KΩ/0.5W	1.5KΩ/0.5W
16A	2.7KΩ/0.5W	680Ω/0.5W
32A	3.3KΩ/0.5W	220Ω/0.5W
63A	3.3KΩ/0.5W	100Ω/0.5W

Current Ratings J2CE/EJCV	R4 (R7)	Rc (R6)
All ratings	330Ω/1W	150Ω/3W

---

# Additional ITT Cannon products for e-mobility applications

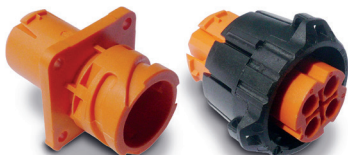

## APD SERIES

This full-plastic, proven bayonet series with IP69K sealing and color and mechanical coding is an ideal solution for harsh environments that require high sealing grades.



## TRIDENT SERIES

This versatile range of metal and plastic electrical connectors with fully interchangeable contacts is available in rectangular and circular configurations, supporting the widest variety of harsh-environment applications.



## CCS1 & CCS2 COOLED HIGH POWER CHARGING SOLUTIONS

This innovative liquid cooled solution can deliver a charge of 500 A at 1,000 V and consists of connector, cable and optional cooling unit. The weight optimized cable design and minimized cable diameter delivers a highly flexible, ergonomic and easy-to-use solution.



## CCS1 & CCS2 UN COOLED CHARGING SOLUTIONS

This un cooled DC charging connector and cable solution is versatile, simple to install and service in-field and engineered to be easily customizable to meet specific customer applications and needs.

Connect with your ITT Cannon representative today  
or visit us at [www.ittcannon.com](http://www.ittcannon.com)

## Connect with the experts

ITT Cannon is a world leader in the design and manufacture of highly engineered solutions for global e-mobility markets.



ENGINEERED FOR LIFE

---

### North America

56 Technology Drive  
Irvine, CA 92618  
Phone +1.800.854.3028

### Europe

Italy  
Corso Europa 41/43  
I - 20020 Lainate (MI) Italy  
Phone: +39.02938721

Germany  
Cannonstrasse 1  
71384 Weinstadt, Germany  
Phone: +49.7151.699.0

### Asia

Tuopandun Industrial Area, Jinda Cheng,  
Xiner Village, Shajing Town, Boan District,  
Shenzhen City, Guangdong Province, China 518215  
Phone: +86.755.2726.7888