

REV	ECN	DESCRIPTION	DATE	MODIFIED
1		RELEASE	Nov-01-2023	Jonny
2	R7941N	UPDATED INLET DIMENSIONS	Mar-28-2024	Jonny

ORIGINAL
PDF Format
R&D

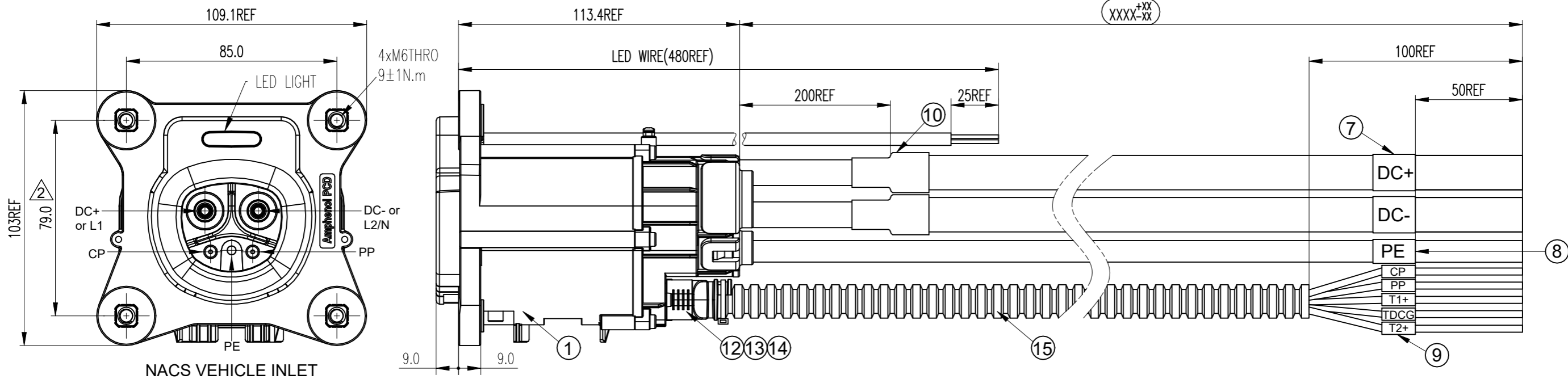

HVCONF0101DL XXXX

LENGTH	TOLERANCE
0~1000mm	+25 -10
1001~5000mm	+40 -10
>5000mm	+50 -20

DIMENSIONS	TOLERANCES	PROJECTION	TITLE			
ANSI Y14.5M UNITS: MM CAD FILE	.X ± 0.5 .XX ± 0.05 ANGLES ± 2.0°		NACS Vehicle Inlet DC1000V/200A;With 12V LED Cable Assembly			
ORIGINAL	THIS DOCUMENT CONTAINS PROPRIETARY INFORMATION WHICH IS THE CONFIDENTIAL PROPERTY OF Amphenol PCD Shenzhen Co. Ltd Amphenol PCD Shenzhen Co. Ltd RESERVES THE RIGHT TO CLARIFY THIS DRAWING	Amphenol PCD Shenzhen ENGR Jonny Mar-28-2024				
			CHKD <i>Rock.chen</i> APPD <i>Ben</i>	SCALE N/A	SHEET 1 OF 2	

WIRE DIAGRAM FOR LED INDICATOR LIGHT

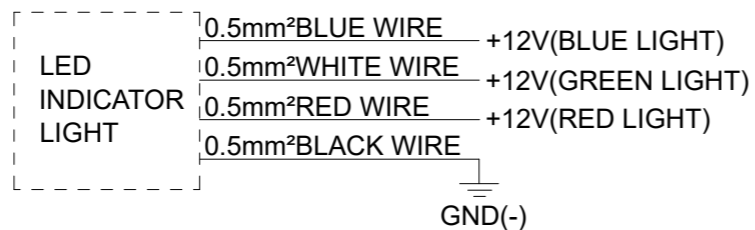

CABLE CONNECT METHOD

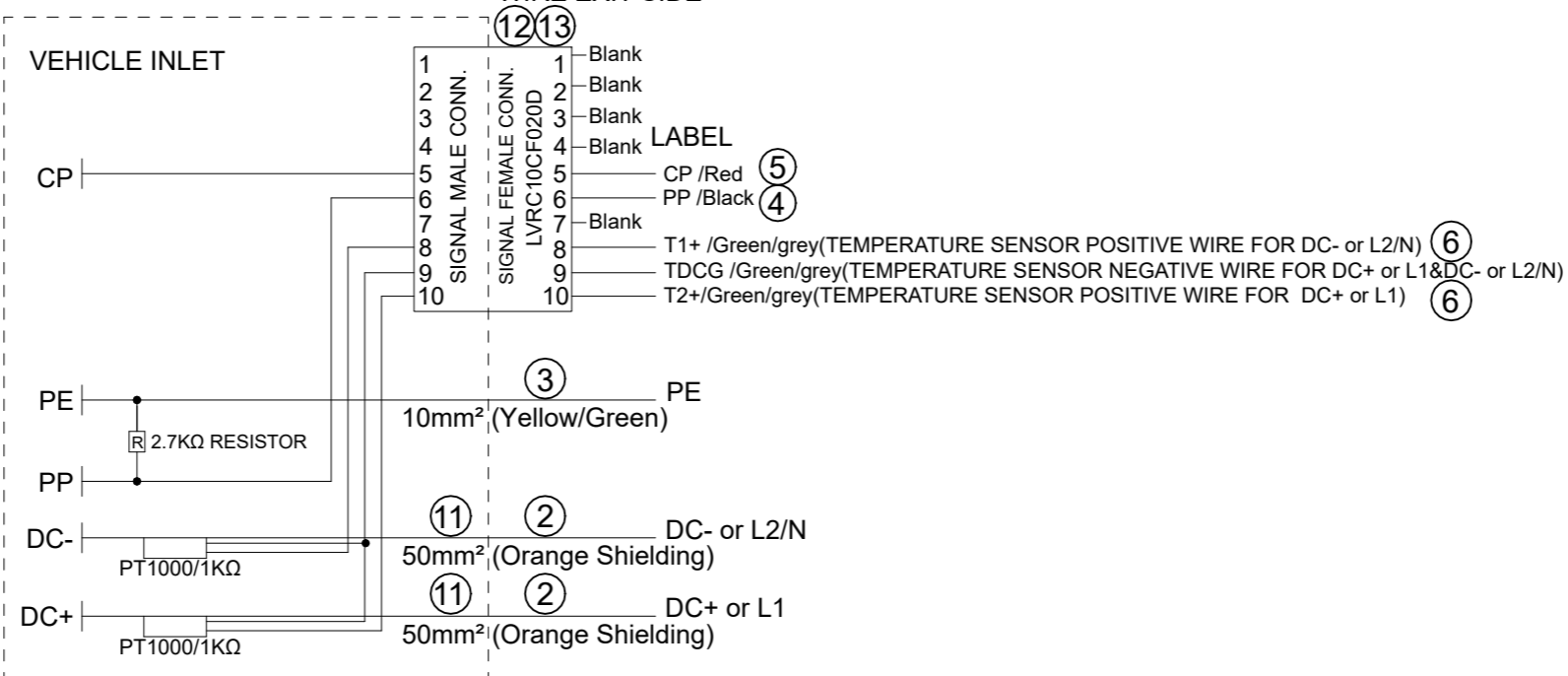

*Notes:

1.Cable Assembly Data:

★ Rated Voltage&Rated Current:

DC:1000V DC, 200A Max;

PE: 10mm² Ground;

CP:30V DC 2A;

PP:30V DC 2A;

★ Insulation Resistance:100MΩ Min(DC 1000V /DC+&DC-);
100MΩ Min(DC 500V /CP);

★ Withstand Voltage:3000V/AC r.m.s(DC+&DC-);
500V/AC r.m.s(CP);

★ IP-CLASS: IP44(Mated)

IP67&IP6K9K(INNER AREA OF VEHICLE INLET)

©Durability:10000 cycles(NACS PLUG);

★RoHS Compliance;

Ambient Temperature: -30°C to +50°C;

Insertion & Withdrawal Force: <100N

2.NACS Inlet Reference: C-HVCONF01XXD

3.NACS Inlet Reference Standard: UL2251;SAE J3400

4.The cable should be fixed at 100mm max from the rear of connector

5.Cable Minimum Bending Radius:≥5OD

6.E-Lock to be ordered separately P/N: HVEL12NS001,Mounting torque is 0.5±0.025 N.m

⑮	P05Z000089	CONVOLUTED TUBING BLACK: 8.5*11.5mm	AR	m
⑭	C210003609	CABLE TIE BLACK	1	EA
⑬	P01BS00025	SIGNAL TERMINAL: P01BS00025 FOR 0.5-0.75mm ²	5	EA
⑫	LVRC10CF020D	SIGNAL CONNECTOR: LVRC10CF020D 10POS	1	EA
⑪	C2100054203	SINGLE-WALL H.S.T: Ø20mm BLACK	0.10	m
⑩	C210006501	DOUBLE-WALL H.S.T: Ø20mm BLACK	0.15	m
⑨	C210006837	SINGLE-WALL H.S.T: Ø3.2mm WHITE	0.10	m
⑧	C210021008	SINGLE-WALL H.S.T: Ø8.0mm WHITE	0.05	m
⑦	C210004340	SINGLE-WALL H.S.T: Ø20mm WHITE	0.10	m
⑥	P01BC00159	1C*0.75mm ² UNSHIELDING, GREEN/GREY, XLPE, OD1.8±0.1	AR	m
⑤	P01BC00187	1C*0.75mm ² UNSHIELDING, RED, XLPE, OD1.8±0.1	AR	m
④	P01BC00186	1C*0.75mm ² UNSHIELDING, BLACK, XLPE, OD1.8±0.1	AR	m
③	P01BC00242	1C*10mm ² UNSHIELDING, YELLOW/GREEN, XLPE, OD6.20±0.25	AR	m
②	P01BC00519	1C*50mm ² SHIELDING, ORANGE, XLPE, ID11.85±0.35, OD15.5±0.3	AR	m
①	HVCONF0101D	NACS VEHICLE INLET: HVCONF0101D, 200A, WITH 12V LED	1	EA
ITEM	P/N	DESCRIPTION	QTY	UNIT

SIZE	DWG NO.	REV
A3	C-HVCONF0101DLXXXX	2
SCALE	N/A	SHEET 2 OF 2