

DOCUMENT No. KSU-604	TITLE PRODUCT SPECIFICATIONS 製品仕様書	PAGE 1/8												
PRODUCT No. SKSUBCE010	For reference 参考	Date: 201908												
<p>1. General 一般事項</p> <p>1.1 Application 適用範囲 This specification is applied to TACT switch which have no key-top. この規格書は、キートップなしのタクトスイッチについて 適用する。</p> <p>1.2 Operating temperature range 使用温度範囲: <u>-40</u> ~ <u>90</u> °C (normal humidity, normal air pressure 常湿・常圧) Operating temperature range shall refer to the range where this switch electrically makes ON/OFF within such temperature. 使用温度範囲とはスイッチがON-OFF機能を維持する温度範囲を言う。</p> <p>1.3 Storage temperature range 保存温度範囲: At Switch level 単品状態 <u>-40</u> ~ <u>90</u> °C (normal humidity, normal air pressure 常湿・常圧) Switch on Taping テーピング状態 <u>-20</u> ~ <u>50</u> °C (humidity 湿度: 20~85%)</p> <p>1.4 Test conditions 試験状態 Unless otherwise specified, the atmospheric conditions for making measurements and tests are as follows. 試験及び測定は特に規定がない限り以下の標準状態のもとで行う。 Normal temperature 常 温: (Temperature 温度 5~35°C) Normal humidity 常 湿: (Relative humidity 湿度 25~85%) Normal air pressure 常 圧: (Air pressure 気圧 86~106kPa) If any doubt arise from judgement, tests shall be conducted at the following conditions. ただし、判定に疑義を生じた場合は以下の基準状態で行う。 Ambient temperature 温 度: 20±2°C Relative humidity 相対湿度: 60~70% Air pressure 気 圧: 86~106kPa Switch shall be mounted on PWB without any indication of switch floating. スイッチは回路基板から浮かないように取り付ける。</p> <p>2. Appearance, style and dimensions 外観、形状、寸法</p> <p>2.1 Appearance 外観 There shall be no defects that affect the serviceability of the product. 性能上有害な欠陥があってはならない。</p> <p>2.2 Style and dimensions 形状、寸法 Refer to the assembly drawings. 製品図による。</p> <p>3. Type of actuating 動作形式 <u>Tactile feedback</u> <u>タクティールフィードバック</u></p> <p>4. Contact arrangement 回路形式 <u>1 poles 1 throws</u> <u>1 回路 1 接点</u> (Details of contact arrangement are given in the assembly drawings 回路の詳細は製品図による)</p> <p>5. Ratings 定格</p> <p>5.1 Maximum ratings 最大定格 <u>16 V DC</u> <u>50 mA</u></p> <p>5.2 Minimum ratings 最小定格 <u>1 V DC</u> <u>10 μA</u></p> <p>6. Electrical specification 電気的性能</p> <table border="1"> <thead> <tr> <th>Items 項目</th> <th>Test conditions 試験条件</th> <th>Criteria 判定基準</th> </tr> </thead> <tbody> <tr> <td>6.1 Contact resistance 接触抵抗</td> <td>Applying a below static load to the center of the stem, measurements shall be made. スイッチ操作部中央に下記の静荷重を加え、測定する。 (1) Depression 押圧力: <u>6 N</u> (2) Measuring method 測定方法: 1 kHz small-current contact resistance meter or voltage drop method at 5VDC 10mA. 1kHz微小電流接触抵抗計, 又はDC5V 10mA電圧降下法</td> <td><u>100 mΩ</u> Max.</td> </tr> <tr> <td>6.2 Insulation resistance 絶縁抵抗</td> <td>Measurements shall be made following the test set forth below: 下記条件で試験を行った後、測定する。 (1) Test voltage 印加電圧: <u>100 V DC</u> for 1 min. (2) Applied position 印加場所: Between all terminals. And if there is a metal frame, between terminals and ground(frame) 端子間, 金属フレームがある場合は, 端子と金属フレーム間</td> <td><u>100 MΩ</u> Min.</td> </tr> <tr> <td>6.3 Voltage proof 耐電圧</td> <td>Measurements shall be made following the test set forth below: 下記条件で試験を行った後、測定する。 (1) Test voltage 印加電圧: <u>250 V AC</u> (50~60Hz) (2) Duration 印加時間: 1 min (3) Applied position 印加場所: Between all terminals. And if there is a metal frame, between terminals and ground (frame) 端子間, 金属フレームがある場合は, 端子と金属フレーム</td> <td>There shall be no breakdown. 絶縁破壊のないこと。</td> </tr> </tbody> </table>			Items 項目	Test conditions 試験条件	Criteria 判定基準	6.1 Contact resistance 接触抵抗	Applying a below static load to the center of the stem, measurements shall be made. スイッチ操作部中央に下記の静荷重を加え、測定する。 (1) Depression 押圧力: <u>6 N</u> (2) Measuring method 測定方法: 1 kHz small-current contact resistance meter or voltage drop method at 5VDC 10mA. 1kHz微小電流接触抵抗計, 又はDC5V 10mA電圧降下法	<u>100 mΩ</u> Max.	6.2 Insulation resistance 絶縁抵抗	Measurements shall be made following the test set forth below: 下記条件で試験を行った後、測定する。 (1) Test voltage 印加電圧: <u>100 V DC</u> for 1 min. (2) Applied position 印加場所: Between all terminals. And if there is a metal frame, between terminals and ground(frame) 端子間, 金属フレームがある場合は, 端子と金属フレーム間	<u>100 MΩ</u> Min.	6.3 Voltage proof 耐電圧	Measurements shall be made following the test set forth below: 下記条件で試験を行った後、測定する。 (1) Test voltage 印加電圧: <u>250 V AC</u> (50~60Hz) (2) Duration 印加時間: 1 min (3) Applied position 印加場所: Between all terminals. And if there is a metal frame, between terminals and ground (frame) 端子間, 金属フレームがある場合は, 端子と金属フレーム	There shall be no breakdown. 絶縁破壊のないこと。
Items 項目	Test conditions 試験条件	Criteria 判定基準												
6.1 Contact resistance 接触抵抗	Applying a below static load to the center of the stem, measurements shall be made. スイッチ操作部中央に下記の静荷重を加え、測定する。 (1) Depression 押圧力: <u>6 N</u> (2) Measuring method 測定方法: 1 kHz small-current contact resistance meter or voltage drop method at 5VDC 10mA. 1kHz微小電流接触抵抗計, 又はDC5V 10mA電圧降下法	<u>100 mΩ</u> Max.												
6.2 Insulation resistance 絶縁抵抗	Measurements shall be made following the test set forth below: 下記条件で試験を行った後、測定する。 (1) Test voltage 印加電圧: <u>100 V DC</u> for 1 min. (2) Applied position 印加場所: Between all terminals. And if there is a metal frame, between terminals and ground(frame) 端子間, 金属フレームがある場合は, 端子と金属フレーム間	<u>100 MΩ</u> Min.												
6.3 Voltage proof 耐電圧	Measurements shall be made following the test set forth below: 下記条件で試験を行った後、測定する。 (1) Test voltage 印加電圧: <u>250 V AC</u> (50~60Hz) (2) Duration 印加時間: 1 min (3) Applied position 印加場所: Between all terminals. And if there is a metal frame, between terminals and ground (frame) 端子間, 金属フレームがある場合は, 端子と金属フレーム	There shall be no breakdown. 絶縁破壊のないこと。												

DOCUMENT No. KSU-604		TITLE PRODUCT SPECIFICATIONS 製品仕様書		PAGE 2/8
PRODUCT No. SKSUBCE010		For reference 参考		Date: 201908
Items 項目	Test conditions 試験条件	Criteria 判定基準		
6.4 Bounce バウンス	<p>Lightly striking the center of the stem at a rate encountered in normal use (3 to 4 operations per s.), bounce shall be tested at "ON" and "OFF". スイッチ操作部の中央部を通常の使用状態(3~4回/秒)で軽く打鍵し、ON時及びOFF時のバウンスを測定する。</p> 	<p>ON bounce : <u>10</u> ms Max. OFF bounce: <u>10</u> ms Max.</p>		
7. Mechanical specification 機械的性能				
Items 項目	Test conditions 試験条件	Criteria 判定基準		
7.1 Operating force 作動力	<p>Placing the switch such that the direction of switch operation is vertical and then gradually increasing the load applied to the center of the stem, the maximum load required for the switch to come to a make "ON" shall be measured. スイッチの操作方向が垂直になる様にスイッチを設置し、操作部中央部に徐々に荷重を加え、スイッチがONするまでの最大荷重を測定する。</p>	<u>3.0 ± 0.6</u> N		
7.2 Travel 移動量	<p>Place the switch such that the direction of switch operation is vertical. Apply the specified static force to the center of the stem. Measure the switch total height from housing bottom face when switch makes ON. スイッチの操作方向が垂直になる様にスイッチを設置し、操作部中央部に以下の静荷重を加え、スイッチがONするまでの距離を測定する。 (1) force 押圧力: <u>3.6</u> N</p>	<u>0.9 ± 0.3</u> mm		
7.3 Return force 復帰力	<p>The sample switch is installed such that the direction of switch operation is vertical and, upon depression of the stem in its center the travel distance, the force of the stem to return tot its free position shall be measured. スイッチの操作方向が垂直になる様にスイッチを設置し、操作部中央部を移動量押圧後、操作部が復帰する力を測定する。</p>	<u>0.5</u> N Min.		
7.4 Stop strength ストッパー強度	<p>Placing the switch such that the direction of switch operation is vertical and then a below static force shall be applied in the direction of stem operation. スイッチの操作方向が垂直になる様にスイッチを設置し、スイッチの操作方向へ以下の静荷重を加える。 (1) Depression 押圧力: <u>50</u> N (2) Time 時間: <u>15</u> s</p>	<p>Keep electrical ON/OFF. 電氣的にON-OFFすること。 Item 6.1</p>		
8. Environmental specification 耐候性能				
Items 項目	Test conditions 試験条件	Criteria 判定基準		
8.1 Resistance to low temperatures 耐寒性	<p>Following the test set forth below the sample shall be left in normal temperature and humidity conditions for 1 h before measurements are made: 次の試験後、常温、常湿中に1時間放置後測定する。 (1) Temperature 温度: <u>-40 ± 2</u> °C (2) Time 時間: <u>1000</u> h (3) Waterdrops shall be removed. 水滴は取り除く。</p>	<p>Item 6. Item 7.1 Item 7.2</p>		
8.2 Heat resistance 耐熱性	<p>Following the test set forth below the sample shall be left in normal temperature and humidity conditions for 1 h before measurements are made: 次の試験後、常温、常湿中に1時間放置後測定する。 (1) Temperature 温度: <u>90 ± 2</u> °C (2) Time 時間: <u>1000</u> h</p>	<p>Item 6. Item 7.1 Item 7.2</p>		
8.3 Moisture resistance 耐湿性	<p>Following the test set forth below the sample shall be left in normal temperature and humidity conditions for 1 h before measurements are made: 次の試験後、常温、常湿中に1時間放置後測定する。 (1) Temperature 温度: <u>60 ± 2</u> °C (2) Time 時間: <u>1000</u> h (3) Relative humidity 相对湿度: <u>90 ~ 95</u> % (4) Waterdrops shall be removed. 水滴は取り除く。</p>	<p>Contact resistance 接触抵抗(Item 6.1) : <u>500</u> mΩ Max. Insulation resistance 絶縁抵抗(Item 6.2) : <u>10</u> MΩ Min. Item 6.3 Item 6.4 Item 7.1 Item 7.2</p>		

DOCUMENT No. KSU-604		TITLE PRODUCT SPECIFICATIONS 製品仕様書	PAGE 3/8
PRODUCT No. SKSUBCE010		For reference 参考	Date: 201908
Items 項目	Test conditions 試験条件	Criteria 判定基準	
8.4 Change of temperature 温度サイクル	<p>After below cycles of following conditions, the switch shall be allowed to stand under normal room temperature and humidity conditions for 1 h, and measurement shall be made. Water drops shall be removed. 下記条件で以下回数のサイクル試験後、常温常湿中に1時間放置し測定する。ただし、水滴は取り除く。</p>  <p style="margin-left: 400px;"> A = +90 °C B = -40 °C C = 2 h D = 1 h E = 2 h F = 1 h </p> <p style="margin-left: 400px;"> (1) Number of cycles サイクル数 : 166 cycles </p>	Item 6. Item 7.1 Item 7.2	
8.5 Resistance to hydrogen sulfide gas. (H ₂ S) 耐硫化ガス性	<p>Following the test set forth below the sample shall be left in normal temperature and humidity conditions for 1 h, and shall be operated two or three times before measurements are made: 次の試験後、常温、常湿中に1時間放置し、2~3回操作後、測定する。</p> <p>(1) Concentration of H₂S gas. H₂Sガス濃度: 1 ppm (2) Temperature 温度 : 40 °C (3) Relative humidity 相対湿度 : 75 % (4) Time 時間 : 240 h</p>	Contact resistance 接触抵抗(Item 6.1) : 1 Ω Max.	
8.6 Resistance to sulfur dioxide. (SO ₂) 耐亜硫酸ガス性	<p>Following the test set forth below the sample shall be left in normal temperature and humidity conditions for 1 h, and shall be operated two or three times before measurements are made: 次の試験後、常温、常湿中に1時間放置し、2~3回操作後、測定する。</p> <p>(1) Concentration of SO₂ gas. SO₂ガス濃度: 10 ppm (2) Temperature 温度 : 40 °C (3) Relative humidity 相対湿度 : 75 % (4) Time 時間 : 240 h</p>	Contact resistance 接触抵抗(Item 6.1) : 1 Ω Max.	
8.7 Protection 保護構造 IP6X equivalent IP6X相当	<p>•Dust protection 保護(塵埃) Let the test samples be exposed to the below test condition. After the test, measurement shall be made. 次の(1)~(4)の試験後、測定する。</p> <p>(1) Amount of talc タルクの量: 2 kg/m³ (2) Time of circulation 循環の時間: 8 h (3) Simply leave switch itself inside dust chamber. スイッチを試験装置室内に動作させずに放置する。 (4) Dusts shall be removed. 表面の塵埃は取り除く。</p>	Contact resistance 接触抵抗(Item 6.1) : 100 m Ω Max. No penetration of dusts shall be found inside of switch. 塵埃の浸入なきこと	
IPX7	<p>•Water protection 保護(水) Let the test samples be exposed to the below test condition. Measurement shall be made after 1 hr soak at normal temperature/humidity. 次の(1)~(4)の試験後、常温、常湿中に1時間放置後測定する。</p> <p>(1) Depth of Immersion 浸漬深さ : 1 m (height from the top of switch and water surface スイッチの上端から水面までの距離) (2) Duration of Immersion 浸漬時間 : 30 min 分 (3) Simply leave switch itself inside water chamber. スイッチを試験装置室内に動作させずに放置する。 (4) Water drops shall be removed. 水滴は取り除く。</p>	Insulation resistance 絶縁抵抗(Item 6.2) : 100 M Ω Min. No outstanding penetration of water which effects the functionality of switch. スイッチ性能に影響を与える水の浸入なきこと	

DOCUMENT No. KSU-604	TITLE PRODUCT SPECIFICATIONS 製品仕様書	PAGE 4/8
PRODUCT No. SKSUBCE010	For reference 参考	Date: 201908
9. Endurance specification 耐久性能		
Items 項目	Test conditions 試験条件	Criteria 判定基準
9.1 Operating life 動作寿命	Measurements shall be made following the test set forth below: 下記条件で試験を行った後, 測定する。 (1) <u>16</u> VDC <u>50</u> mA resistive load 抵抗負荷 (2) Rate of operation 動作速度: <u>2</u> to <u>3</u> operations per s 回/秒 (3) Depression 押圧力: <u>3.6</u> N (4) Cycles of operation 動作回数: <u>250,000</u> cycles 回	Contact resistance 接触抵抗(Item 6.1): <u>1</u> Ω Max. Insulation resistance 絶縁抵抗(Item 6.2): <u>10</u> MΩ Min. Bounce バウンス(Item 6.4): ON bounce: <u>20</u> ms Max. OFF bounce: <u>20</u> ms Max. Operating force 作動力(Item 7.1): <u>±30</u> % of initial force 初期値に対して Travel 移動量(Item 7.2): <u>+40/-10</u> % of initial travel 初期値に対して Item 6.3
9.2 Vibration resistance 耐振性	Measurements shall be made following the test set forth below: 下記条件で試験を行った後, 測定する。 (1)Vibration frequency range 振動数範囲: <u>10</u> ~ <u>55</u> Hz (2)Total amplitude 全振幅: <u>1.5</u> mm (3)Sweep ratio 掃引の割合: <u>10-55-10</u> Hz Approx. <u>1</u> min 約1分 (4)Method of changing the sweep vibration frequency : Logarithmic or uniform 掃引振動数の変化方法 対数又は一様掃引 (5)Direction of vibration: Three mutually perpendicular directions, including the direction 振動の方向 of the travel スイッチ操作方向を中心とした垂直3方向 (6)Duration 振動時間: <u>2</u> h each (<u>6</u> h in total) 各 <u>2</u> 時間(計 <u>6</u> 時間)	Item 6.1 Item 7.1 Item 7.2
9.3 Shock 耐衝撃性	Measurements shall be made following the test set forth below: 下記条件で試験を行った後, 測定する。 (1)Acceleration 加速度: <u>980</u> m/s ² (2)Acting time 作用時間: <u>6</u> msec (3)Test direction 試験方向: 6 directions 6面 (4)Number of shocks 試験回数: <u>3</u> times per direction (<u>18</u> times in total) 各方向各 <u>3</u> 回(計 <u>18</u> 回)	Item 6.1 Item 7.1 Item 7.2

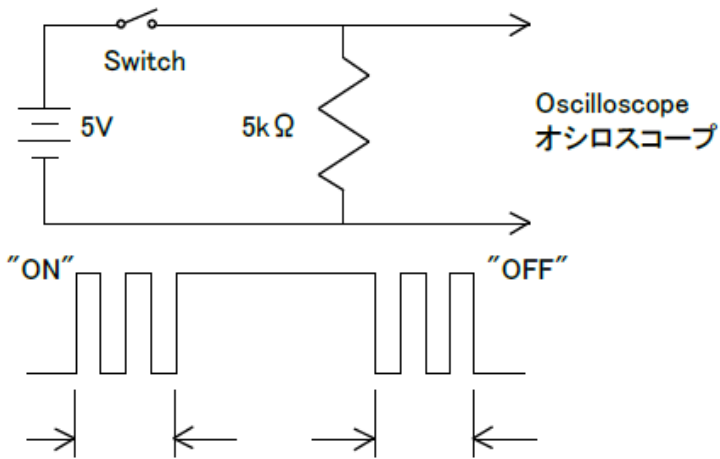
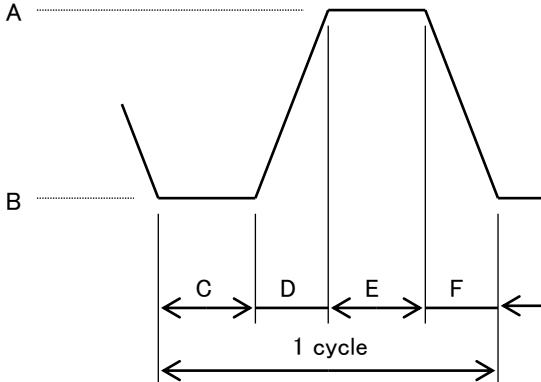
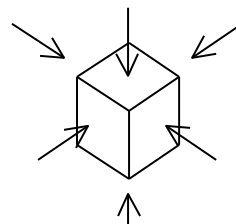

DOCUMENT No. KSU-604	TITLE PRODUCT SPECIFICATIONS 製品仕様書	PAGE 5/8
PRODUCT No. SKSUBCEO10	For reference 参考	Date: 201908
10. Soldering conditions 半田付条件		
	Items 項目	Recommended conditions 推奨条件
10.1	Hand soldering 手半田	<p>Please practice according to below conditions. 以下の条件にて実施して下さい。</p> <p>(1) Soldering temperature 半田温度 : <u>350</u> °C Max. (2) Continuous soldering time 連続半田時間 : <u>3</u> s Max. (3) Capacity of soldering iron 半田コテ容量 : <u>60</u> W Max. (4) Excessive pressure shall not be applied to the terminal. 端子に異常加圧のないこと (5) Safeguard the switch assembly against flux penetration from its topside. スイッチの上面からフラックスが浸入しない様にして下さい。</p>
10.2	Reflow soldering リフロー半田	<p>Please practice according to below conditions. 以下の条件にて実施して下さい。</p> <p>(1) Profile 温度プロファイル</p> <p>Surface of product Temperature 部品表面温度(°C)</p> <p>(2) Allowable soldering time 半田回数 : <u>2</u> time Max. (The temperature shall go down to a normal temperature in prior to exposure to the second time : 2回目を行う場合には、スイッチが常温に戻ってから行うこと。)</p>
10.3	Other precautions For soldering 半田付けに関する その他注意事項	<p>(1) Switch terminals and PWB. Upper face shall be free from flax prior to soldering. 事前にスイッチの端子及びプリント基板の部品実装面上にフラックスが塗られていないこと。</p> <p>(2) Following the soldering process, do not try to clean the switch with a solvent or the like. 半田付け後、溶剤などでスイッチを洗浄しないで下さい。</p> <p>(3) Recommended cream solder: M705-GRN360-K2-V (SENJU METAL INDUSTRY CO.,LTD) or equivalent 推奨クリーム半田: 千住金属工業(株) M705-GRN360-K2 同等品</p> <p>(4) When chip components is soldered on the back side of PWB by automatic flow soldering, after this switch soldered by reflow soldering, flux will possibly creep up at the exterior wall of the housing and penetrate into the housing due to flux ejection. Therefore, when the PWB is designed, please do not locate through holes adjacent to the switch mounted area. 本スイッチをリフロー半田後、プリント基板裏面をディップ半田して使用する場合は、ディップ時のフラックス吹き上げ等によりスイッチ側面からフラックスがはい上がる場合がありますので、パターン設計にあたってはスイッチ下面、周囲にスルーホールを設けないで下さい。</p> <p>(5) As the conditions vary somehow depending on the kind of reflow soldering equipment, please make sure you have the right one before use. リフロー槽の種類により、多少条件が異なりますので、事前に十分確認の上使用して下さい。</p> <p>(6) As the click rate may deteriorate when heat is applied repeatedly, reflow soldering should be performed in the shortest period and at the lowest temperature possible. 熱履歴が加わるとクリック感が低下する可能性がありますので極力低温短時間でリフローを行うようにお願いします。</p> <p>(7) Safeguard the switch assembly against flux penetration from its top side. スイッチの上面からフラックスが浸入しないようにして下さい。</p> <p>(8) The thickness of cream solder paste : <u>0.15</u> mm クリーム半田印刷厚 : <u>0.15</u> mm</p>

DOCUMENT No. KSU-604	TITLE PRODUCT SPECIFICATIONS 製品仕様書	PAGE 6/8
PRODUCT No. SKSUBCE010	For reference 参考	Date: 201908
<p>【Precaution in use】ご使用上の注意</p> <p>A. General 一般項目</p> <p>A1. For the export of products which are controlled items subject to foreign and domestic export laws and regulations, you must obtain approval and/or follow the formalities of such laws and regulations. 国内外の輸出関連法規により規制されている製品の輸出に際しては、同法規を遵守の上、必要な許可、手続き等をとってください。</p> <p>A2. Products must not be used for military and/or antisocial purposes such as terrorism, and shall not be supplied to any party intending to use the products for such purposes. 軍用途又はテロ等の反社会活動目的では、当製品を一切使用しないでください。また、最終的にそれら用途・目的で使用されるおそれがある法人・団体・個人等へも当製品を一切供給しないでください。</p> <p>A3. Unless provided otherwise, the products have been designed and manufactured for application to equipment and devices which are sold to end-users in the market, such as AV (audio visual) equipment, home electric equipment, office and commercial electronic equipment, information and communication equipment or amusement equipment. The products are not intended for use in, and must not be used for, any application of nuclear equipment, driving control equipment for aerospace or any other unauthorized use. With the exception of the above mentioned banned applications, for applications involving high levels of safety and liability such as medical equipment, burglar alarm equipment, disaster prevention equipment and undersea equipment, please contact an Alps sales representative and/or evaluate the total system on the applicability. Also, implement a fail-safe design, protection circuit, redundant circuit, malfunction protection and/or fire protection into the complete system for safety and reliability of the total system. 当製品は、特に用途を指定していないかぎり、本来、AV、家電、事務機、情報機器、通信機器、アミューズメント機器等の一般電子機器用に設計、製造されたものです。従いまして、原子力制御機器、宇宙・航空機で運行にかかわる機器等の用途では一切使用しないでください。上記の使用禁止の用途以外で、医療機器、防犯機器、防災機器、海底用機器等の高度の安全性・信頼性を必要とする機器でのご使用の際は、弊社営業担当迄ご相談いただくか、またはセットでの十分な適合性の確認を行っていただいた上で、フェールセーフ設計、保護回路、冗長回路、誤動作防止設計、延焼対策設計等のセットでの安全対策設計を設けてください。</p> <p>A4. This product is designed and manufactured assuming that it is to be used with the resistance for direct current. If you use other kinds of resistance (inductive (L) or capacitive (C)), please let us know beforehand. 本製品は直流の抵抗負荷を想定して設計・製造されています。その他の負荷(誘導性負荷(L)、容量性負荷(C))で使用される場合は、別途ご相談ください。</p> <p>B. Soldering and assemble to PWBoard process 半田付、基板実装工程</p> <p>B1. Note that if the load is applied to the terminals during soldering they might suffer deformation and defects in electrical performance. 端子をはんだ付けされる場合、端子に荷重が加わりますと条件によりガタ、変形及び電気的特性劣化のおそれがありますのでご注意ください。</p> <p>B2. Conditions of soldering shall be confirmed under actual production conditions. はんだ付けの条件の設定については、実際の量産条件で確認されるようお願いいたします。</p> <p>B3. As this switch is designed for reflow soldering, if you place it at the edge of PWB for convenience, then flux may get into the sliding part of the SW during automatic dip soldering after being mounted, so do not apply auto dip after being mounted. 当スイッチはリフロー半田対応ですが、スイッチ実装後にオートディップを行う場合にスイッチが基板の端にあるとフラックスが浸入する恐れがありますので十分にご注意下さい。</p> <p>B4. As the click rate may deteriorate when heat is applied repeatedly, reflow soldering should be done within the recommended conditions. 熱履歴が加わるとクリック感が低下する可能性がありますので推奨リフロー条件以内でリフローを行う様をお願いします。</p> <p>B5. If the stem is given stress from the side, it may result in damages to switch functions. Therefore please handle it with extreme care. When the switch is carried, any shock shall not be applied to the stem. ステムに横からの力が加わりますと、スイッチの機能破壊につながる危険性がありますので取扱いは十分注意して下さい。 移動する場合はステムに衝撃が加わらない様に注意して下さい。</p> <p>B6. Switch shall be mounted without any indication of switch floating between switch bottom and PWB. スイッチ底面と回路基板との間に隙間が生じないように取り付けてください。</p> <p>C. Washing process 洗浄工程</p> <p>C1. This switch shall not be washable with solvents or like after soldering and/or touch-up soldering. 半田付け後及びスイッチ手直し工程時に、溶剤などでスイッチを洗浄しないでください。</p> <p>D. Mechanism design (switch layout) 機構設計</p> <p>D1. When users use a different PWB mounting hole and land footprints/pattern from our recommended dimensions, the prior consultation shall be made with us. プリント基板取り付け穴およびパターンに関し、推奨寸法以外を採用する場合は、当社に連絡願います。</p> <p>D2. You may dip-solder chip components on the backside of PWB after you have reflow-soldered this switch. However, dip-soldering may cause flux to creep up on the wall of the housing and penetrate the switch. Therefore, do not design a through-hole under and around the switch. 本スイッチをリフロー半田後、プリント基板裏面をディップ半田して使用する場合は、ディップ時のフラックス吹き上げ等により、スイッチ側面より、フラックスがはい上がる場合がありますので、パターン設計にあたっては、スイッチ下面、周囲にスルーホールを設けしないで下さい。</p> <p>D3. Ultrasonic welding on the PWB assembly might cause broken switch due to vibration, depending on the welding conditions. e.g. broken calking, peeled dust/water proof sheet. In prior to implementation of such ultrasonic welding, please well check that welding process would not cause any issue to our product. タクトスイッチが搭載され機器の組立工程で超音波溶着を実施される場合は事前にタクトスイッチに異常が生じないか確認を行ってください。 超音波の条件により、スイッチに振動が加わりスイッチが破壊する可能性があります。不具合例:カシメ部破壊、防塵・防水シートの剥がれ。</p> <p>D4. Switch shall not be kept pressed for a long time. スイッチを長時間 ON させる使い方はしないでください。</p> <p>D5. This switch is not designed for keeping pressed down for a certain duration of time. If users intend to use our switch for such purpose, they shall verify such suitability with the own actual samples in advance as well as shall use for this purpose under their sole responsibility. The prior consultation with us is also needed. 本製品は長押しする用途で設計されたものではありません。本製品を長押し使用される場合は当社にご連絡頂き、仕様内容を調整した上で採用可否判断願います。</p>		

DOCUMENT No. KSU-604	TITLE 製品仕様書	PRODUCT SPECIFICATIONS 製品仕様書	PAGE 7/8
PRODUCT No. SKSUBCE010	For reference 参考		Date: 201908

D6. As per Fig 1 and Fig.2, the entire part of the hatched area as well as the center of stem shall be pushed by actuator. Click feeling of switch may be degraded by Off-center push including stem edge due to hinge construction and/or tolerance stack-up at module level.
Hinge construction may cause slant angle push, causing switch to fail to make ON.
本タクトスイッチを操作する際、キートップ先端は図1のようにステム全面を押すようにして下さい。また、図2のようにステムのセンターを押すようにして下さい。ヒンジ構造及びセット上の累積公差によるセンターズレなどステムを端押しする状態では感触が変化する場合があります。ヒンジ構造の場合は、押下時ステム押し位置が移動しますので、動作せずになる可能性があります。

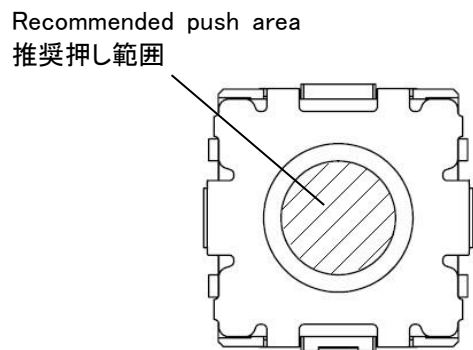

Fig 1: Switch Top View
図1: スイッチ上面図

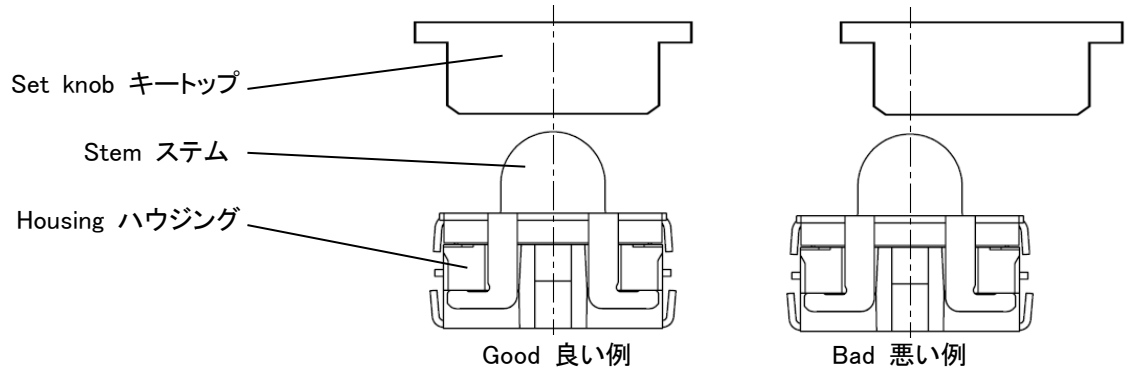
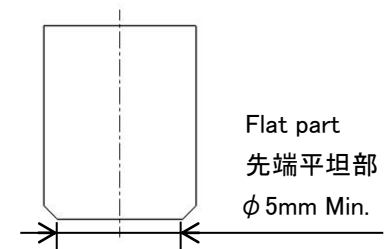

Fig 2: Set knob vs stem
図2: キートップとステムの関係

D7. Actuator Design: 打鍵部先端形状

The actuator of set knob is recommended to be $\phi 5$ mm or larger and flat design (refer to the right figure). Also, the recommended materials of actuator is ABS or PC resin.
右図に示す $\phi 5$ mm以上のフラット形状を推奨いたします。尚、材質はABSまたはPC等の樹脂を推奨致します。



D8. The inclination of the striking part shall be within 3° .
打鍵部の傾斜は、3度以内に設定して下さい。

D9. The switch will be broken, if you give larger stress than specified. Take most care not to let the switch be given larger stress than specified. (Refer to the strength of the stopper.)
スイッチ操作時に規定以上の荷重が加わるとスイッチが破損する場合があります。スイッチに規定荷重以上の力が加わらない様にご注意下さい。(ストッパー強度参照)

D10. Do not apply a side force to the switch stem. Also, the actuator should be guided well not to slide along the switch stem surface. In case the switch stem is exposed to a side push, switch may face angle push/off-center push and/or broken switch. This may potentially cause switch to have degraded click feeling and/or ON/OFF failure.
ステムを横方向に押さないでください。また、キートップをガイドするなど、ステム上をキートップがスライドしないような設定にしてください。ステムが横方向に押されるとステムのオフセンター押しや破壊が起こり、感触の変化や動作せずになる可能性があります。

D11. Please avoid designing keytop to be projecting from set case. This may cause breakage of switch due to mechanical impact applied to switch body.
セットキートップがセット筐体から出るようなご使用方法はお避け下さい。スイッチに衝撃荷重が加わりスイッチ破壊の原因となります。

D12. As per Fig 3, the end stop mechanism at module level shall be located at 2.95 mm or lower from switch bottom including the tolerance of set knob to avoid over-force. In case end stop mechanism is set at higher than 2.95mm from switch bottom, it might potentially cause functional failure. Besides the below designing guide, switch shall not be exposed to larger force than the one specified in item 7.4.
スイッチへの過荷重押し込みを防止する為、セット側でストッパーを設定する場合は、図3に示すように、最大押し込み時のキートップ先端がスイッチ底面から2.95mm以上の位置にならないように設定して下さい。2.95mmより高い位置で設定した場合、動作せずになる可能性があります。尚、下記にてストッパーを設定した場合でも、7.4項に規定するストッパー強度規定以上の力が加わらない様にご注意下さい。

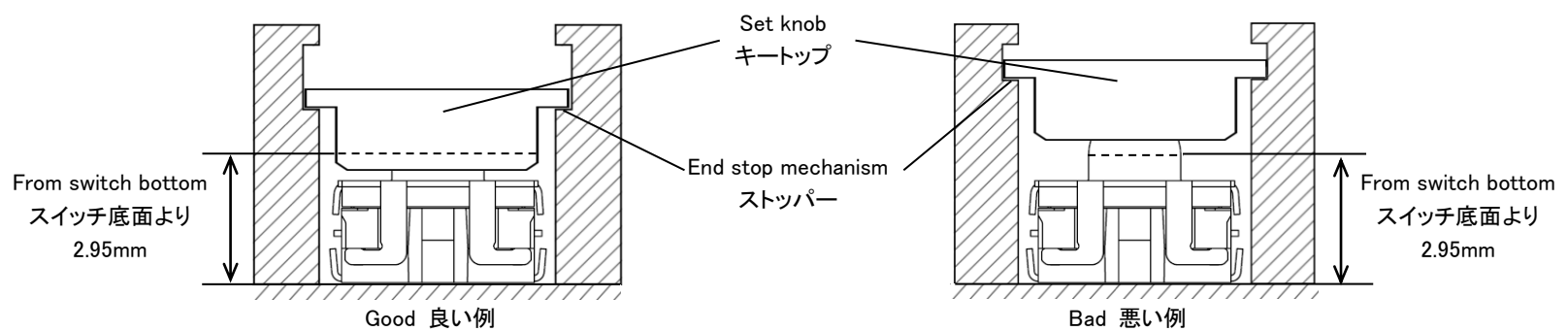

Fig. 3: End stop mechanism at module level (example)
図3: ストッパー位置の例

D13. When adding pre-travel to switch at module level to prevent wobble of set knob, pre-travel shall be set at 3.7mm or higher from switch bottom. In case pre-travel is set at lower than 3.7mm from switch bottom, it may potentially cause functional failure.
キートップのガタ防止の為、スイッチの初期押し込みを設定される場合は、図4に示すようにスイッチ底面から3.7mm未満の位置に設定しないで下さい。3.7mm未満の位置で設定した場合、動作せずになる可能性があります。

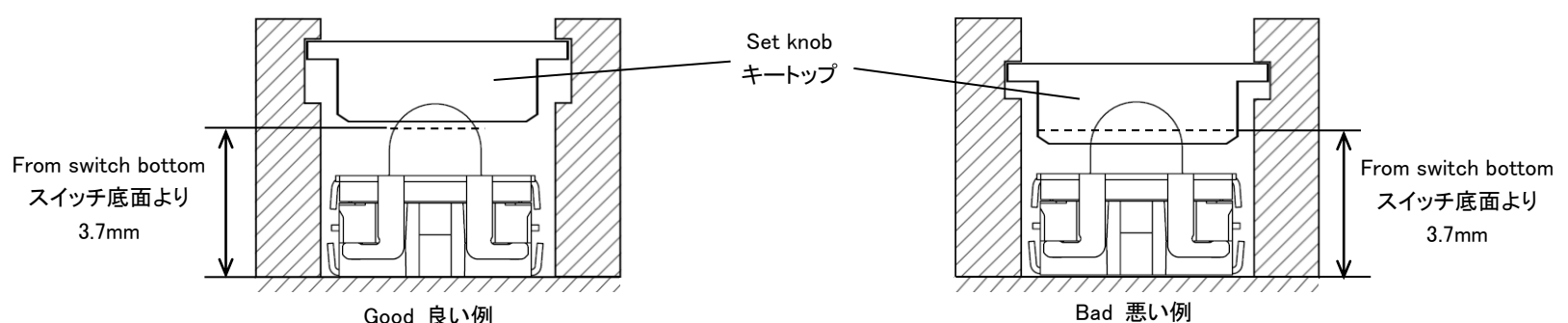

Fig. 4: Initial pre-travel at module level (example)
図4: 初期押し込みの例

DOCUMENT No. KSU-604	TITLE PRODUCT SPECIFICATIONS 製品仕様書	PAGE 8/8
PRODUCT No. SKSUBCE010	For reference 参考	Date: 201908
<p>D14. This switch is designed for unit construction that it is pressed by human operation. Please avoid using this switch as mechanical detecting function. In case such detecting function is required, please consult with our detector switch section. 当スイッチは、直接人の操作を介してスイッチを押す構造にてご使用下さい。メカ的な検出機能へのご使用は避けてください。 検出機能には弊社検出スイッチをご使用下さい。</p> <p>D15. Please make sure that switch is mounted without any flexure of PWB. 基板がたわむような場所への設置は避け下さい。</p> <p>D16. If you intend to change the way of the switch being used on your module, please let us know. セット上でのスイッチの使われ方が変更される際は当社に御連絡ください。</p> <p>E. Using environment 使用環境</p> <p>E1. In case this product is always used around a sulfurate hot spring where sulfide gas is generated or in a place where exhaust gas from automobiles exists, take most care due to the switch performance might be affected. 硫黄系温泉地等常時ガスが発生する場所や自動車等の排気ガスの発生する場所で常時使用する場合、当製品の性能に影響を及ぼすおそれがありますので十分にご注意下さい。</p> <p>E2. Follow the directions if you have parts/materials described below within the module where the switch is installed. 同一セット内に以下の様な部材に関しましては以下の点にご注意願います。 ・For parts, rubber materials, adhesive agents, plywood, packing materials and lubricant used for the mechanical part of the device, do not use those ones that may generate gas of sulfurization or oxidization. 部品、ゴム材料、接着剤、合板、機器の梱包材、機器内の駆動部に使用される潤滑剤については、硫化、酸化ガスを発生しないものを採用してください。 ・When you use silicon rubber, grease, adhesive agents and oil, use those that will not generate low molecular siloxane gas. The low molecular siloxane gas may form silicon dioxide coat on the SW contact part, resulting in the contact failure. シリコン系ゴム、グリース、接着剤、オイルを使用される場合は、低分子シロキサンガスを発生しないものを使用してください。低分子シロキサンガスが発生しますとSW接点部に2酸化珪素の被膜を形成して接点障害を引き起こす場合があります。 ・When you apply chemical agents such as coating agents and greases to the products, please let us know beforehand. 製品のコーティング剤やグリース等の薬品を付着させる場合は、別途ご相談ください。</p> <p>E3. Do not use this switch in the atmosphere with high humidity or with bedewing probability, because such atmosphere may cause leak among terminals. 高湿度環境下、又は結露する可能性がある環境では、端子間の電流リークが発生する可能性がありますので本スイッチはご使用にならないでください。</p> <p>F. Storage method. 保管方法</p> <p>F1. The below usage and/or environment shall be avoided. This product may face an increase in contact resistance and degraded solderability. 本製品を以下の環境下及び期間で保管されますと接触抵抗の上昇やはんだ付け性の悪化が発生する恐れがありますので避けてください。 (1) Storage at lower than -20 dgrs C, higher than +50 dgrs C, and/or lower than 20%, higher than 85% humidity -20℃～+50℃の範囲外の温度、または 20%～85%の範囲外の湿度 (2) Corrosive gas 腐食性ガスの雰囲気。 (3) Longer than 6-month storage after being delivered 製品納入後6ヶ月超える長期保管。 (4) Direct exposure to sunlight 直射日光の当たる場所。</p> <p>F2. Once the original packaging is opened, the remained products shall be repackaged and stored in the ALPSALPINE original packaging. 開封後で残品がある場合、アルプスアルパイン出荷時の梱包状態で保管してください。</p> <p>F3. The products shall be stored in the ALPSALPINE original packaging without overstack or external stress that may potentially cause deformation of packaging. 梱包箱が変形する様な過剰な積み重ねや応力を避けてアルプスアルパイン出荷時の梱包状態のままで保管してください。</p> <p>F4. Key-switches shall be kept as released position, when they are stored. スイッチの操作部を押し切ったままでの保存はしないでください。</p> <p>G. Others. その他</p> <p>G1. This specification will be invalid one year after it is issued, if you don't return it or don't place an order. 本仕様書は発行日より1年間を経過して、ご返却又はご発注の無い場合は、無効とさせていただきます。</p> <p>G2. Please understand that the specifications other than electric and mechanical characteristics and outside dimensions may be changed at our own discretion. 電氣的、機械的特性、外観寸法および取付寸法以外につきましては、当社の都合により変更させて頂く事が有りますので、あらかじめ御了承下さい。</p> <p>G3. The flammability grade of the plastic used for this product is "94HB" by the UL Standard (slow burning). Therefore, either refrain from using it in the place where it can catch fire, or take measures to preclude catching fire. 本製品に使用している樹脂等の燃焼グレードはUL規格の"94HB"(遅燃性グレード)相当を使用しております。つきましては類焼の恐れがある場所での使用を禁止するか、類焼防止対策をお願いします。</p> <p>G4. Though we are confident in switch quality, we cannot deny the possibility that they could fail due to short or open circuit. Therefore, if you use a switch for a product requiring higher safety, we would like you to verify in advance what effects your module would receive in case the switch alone should fail. And secure safety as a whole system by introducing the fail-safe design, i.e. a protection network. スイッチの品質には万全を尽くしていますが故障モードとしてショート、オープンの発生が皆無とは言えません。安全性が重視されるセットの設計に際しては、SWの単品故障に対してセットとしての影響を事前にご検討いただき、保護回路等のフェールセーフ設計のご検討を十分に行い安全確保して頂きますようお願いいたします。</p> <p>G5. Never use the product beyond the rating. It may catch fire. If you think that the product may be used beyond the rating due to some abnormal conditions, you must take certain protective measures, such as a protective circuit to shut down the current. 定格を超えての使用は火災発生のおそれがありますので絶対に避けて下さい。また異常使用等で定格を超える恐れがある場合は保護回路等で電流遮断等の対策をして下さい。</p> <p>G6. TACT Switch is trademark or registered trademark of ALPSALPINE CO., LTD. タクトスイッチはアルプスアルパイン株式会社の商標もしくは登録商標です。</p>		