

HYBRID & ELECTRIC VEHICLE CONNECTION SYSTEM

Off-the-shelf Portfolio



At Aptiv, we are born to move

Aptiv is a **global technology company** that develops safer, greener and more connected solutions enabling a more sustainable future of mobility.

Headquartered in Dublin, Aptiv has more than 200,000 employees and operates 11 technical centers, as well as manufacturing sites and customer support centers in 48 countries.



VISIT [APTIV.COM](https://www.aptiv.com) →

Aptiv is ready when and where you need us

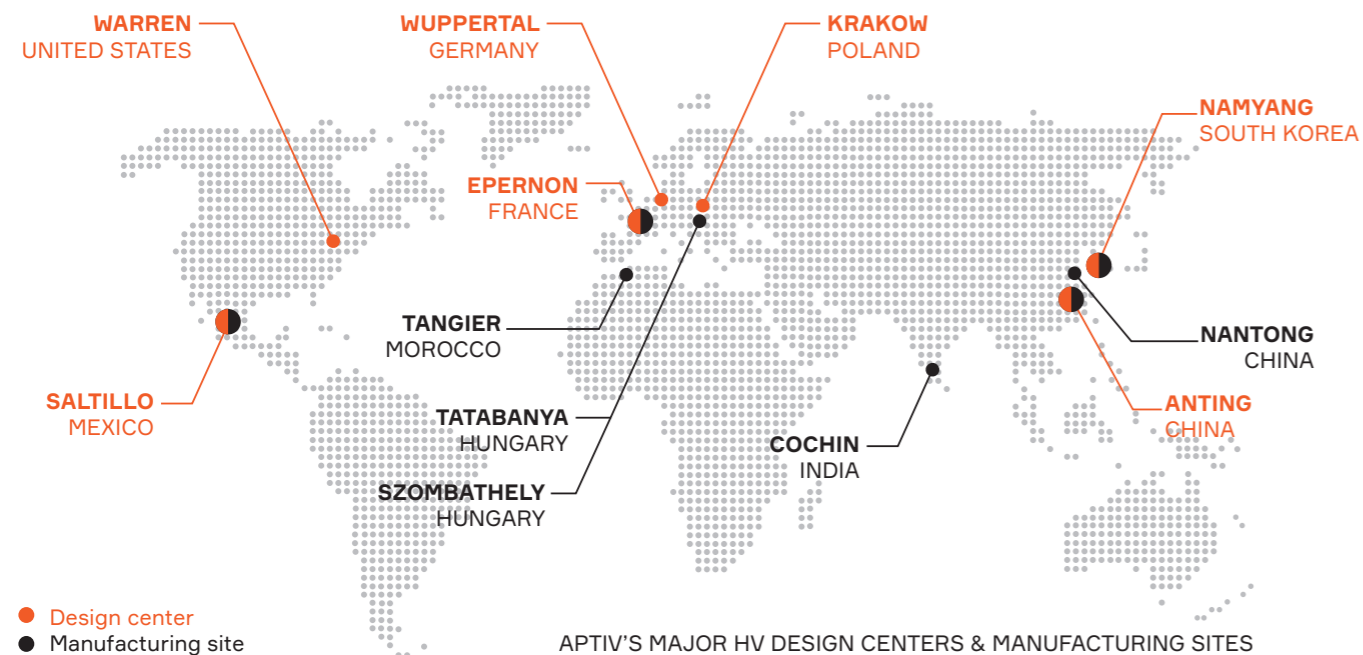

The partner of choice for electrification solutions

System-Level Expertise

Aptiv has over 20 years of field-proven experience in automotive-grade high-voltage solutions. We design and develop connection systems for electrified vehicles, delivering power to the systems that need it most.

Everything in our electrification portfolio, including high-voltage electrical connectors to charging cordsets and inlets, benefits from the knowledge, experience, research and know-how that goes into everything Aptiv builds for the system.

Aptiv engineers understand how to optimize the electrification system to match the overall vehicle architecture and adapt each component to customer-specific design requirements.

Making Mobility Greener

We envision a world with zero emissions. Making the future of mobility greener is at the heart of our mission.

We make intelligent design trade-offs that reduce cost, weight and mass, allowing for faster democratization of technologies that reduce CO2 emissions.

We enable a more sustainable future of mobility.



Did you KNOW?

Hybrid vehicles were once thought to be the next logical step in the evolution toward full EVs. Today, consumers thinking about going electric are more likely to buy an all-electric vehicle than a hybrid model. That shift has major architectural implications for OEMs, because all-electric vehicles must deliver power not only to drive the wheels of the vehicle, but also to run all the other devices that in a gas-powered or hybrid vehicle would be powered by the engine.

The good news is that Aptiv offers innovative solutions to reduce weight and mass while delivering power in a way that makes vehicle assembly safer and less complex.



Why is vehicle electrification now accelerating?



CONSUMER DEMAND



GOVERNMENT REGULATIONS AND INCENTIVES

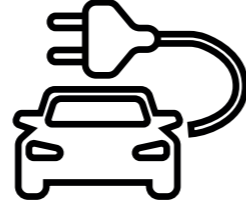

OEM PRODUCTION CAPABILITIES



The long-awaited inflection point for electric vehicles (EVs) has arrived. Consumers are demanding EVs, regulations are tightening, battery prices are falling, and OEMs are ramping up manufacturing capabilities.

This shift to EV architecture brings with it a series of new challenges, and the key for OEMs is to work with an electrification partner that can help design the most efficient, safest, most reliable and most cost-effective system for a vehicle's specific requirements.

With a unique expertise in architecture optimization and systems integration, Aptiv has created one of the most comprehensive portfolios of high-power connection systems. We have the technical expertise and comprehensive product offerings to deliver a complete, integrated solution.

Superior Sealing Performances



All of our mated connection systems feature at least external IP67 sealing performance. To ensure optimum sealing performance, our connectors are designed for the harshest conditions due to a back sealing feature.

Superior Shielding Performances

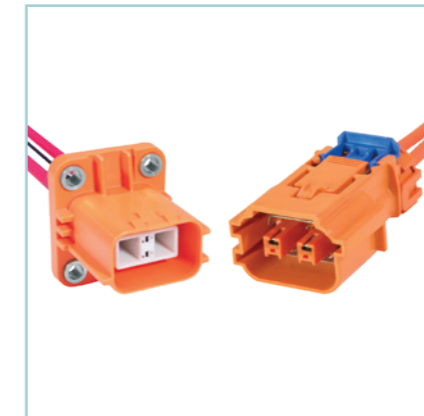

EV and HEV electrical and electronic systems generate unwanted electromagnetic interference (EMI) which radiate from the interconnecting cables. The connection systems are designed by minimizing the paths along which these signals can escape. Our connectors and cabling designs provide high levels of shielding effectiveness to ensure EMI free performance of the complete system.

Superior Safety Performances

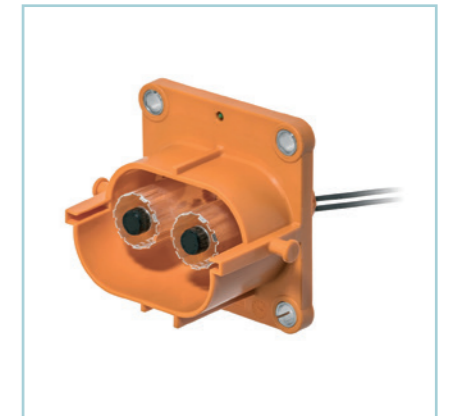

Our connectors provide finger-proof, 2-step disconnection technologies to guarantee optimum safety during all handling operations. They continue to meet with changing requirements of the OEM's in regard to HVIL on a vehicle system and connection system level. Additionally, our ErgoMate™ axial mating system helps achieve a lower profile solution while reducing mating forces. Our solutions offer position assurances in multiple options including: CPA (Connector Position Assurance), TPA (Terminal Position Assurance) and SPA (Screw Position Assurance).

A comprehensive product portfolio

1

High Voltage Auxiliary Modules

APPLICATION:

PTC heater, DC / DC converter, On-Board Charger (OBC), Electric AC, Battery pack, HV PDU



High Voltage connection systems designed specifically for the voltage and current needs of auxiliary modules, such as PTC heater, DC / DC converter, on-board charger (OBC), electric pack and HV power distribution unit (PDU).

See page **10 - 45**

2

High Voltage Power Conversion

HV battery, E-motor, AC / DC inverter, Power electric box, Distribution Unit (HV PDU), DC / DC converter



High Voltage connection systems designed specifically for the voltage and current needs up to 420A. Power conversion modules consist of inverters, drive motors/generators, and high current/high voltage battery outputs.

See page **46 - 81**

3

High Voltage 12, 24, 48 Volt Solutions

48V electrical centers, Power distribution boxes, Start-stop systems, E-turbo, Battery, Active suspension, BSG units, High current harness and devices, Sealed pass-through panel mount systems



Growing requirements and a quickly increasing market for 48 Volt applications drive our technology for innovative solutions. Two key characteristics define these solutions: High current carrying capabilities and high sealing protection.

See page **82 - 89**

4

Charging Solutions

On-vehicle charging inlets, Grid-to-vehicle charging, Charging infrastructure-to-vehicle



With Aptiv products plug-in, hybrid and electric vehicles can be powered safely and efficiently at home or away. Aptiv offers a complete line of all global charging standards: SAE J1772 (North America and Japan), IEC62196 Type II (Europe) and GB/T 20234 (China). In addition, SAE has established a common footprint for DC (Direct Current) fast charging in North America and Europe, better known as Combo 1 and Combo 2.

See page **90 - 97**

Performance key & Aptiv design indicators key

VOLTAGE

Range: 12V - 1000V

AMPERAGE

Range: 10A - 420A

TEMPERATURE

Class	Ambient Temperature Range
T1	-40°C to +85°C
T2	-40°C to +100°C
T3	-40°C to +125°C
T4	-40°C to +150°C

VIBRATION

Class	Common Name	Typical Application
V1	Chassis Profile	Components on sprung portions of vehicle not coupled to Engine
V2	Engine Profile	Components coupled to Engine with severe vibration possible
V3	Severe On-Engine	Components subject to severe vibration
V4	Extreme Vibration	Used as needed to correlate to extreme vibration areas

SEALING CLASS

IP ratings according to IEC 60529

HV Interconnects Naming Keys

HV Interconnects Families

SHIELDPACK™	all HV Shielded connectors
POWERPACK	all HV Unshielded connectors

Terminal Types & Size

APEX	280
CTS	280/630
HES	240
PP	1000/2000
RCS	800/890/1100/1190

Shielding Types

SI	Shielded Individual
SB	Shielded Bundle
SMU	Shielded Multicore
UI	Unshielded Individual

Specifics

DM	Direct Mate
OBC	On-Board Charger
RV	Reduced Version
Splice	Integrated splice function

EXAMPLE:

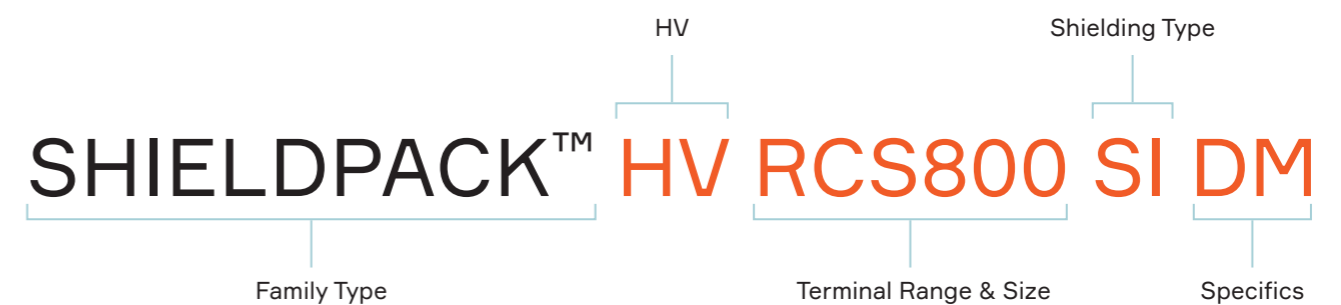

Auxiliary Modules Solutions

SELECTOR GUIDE

APPLICATIONS:

- PTC heater
- DC / DC converter
- On-Board Charger (OBC)
- Electric AC
- Battery pack
- HV PDU

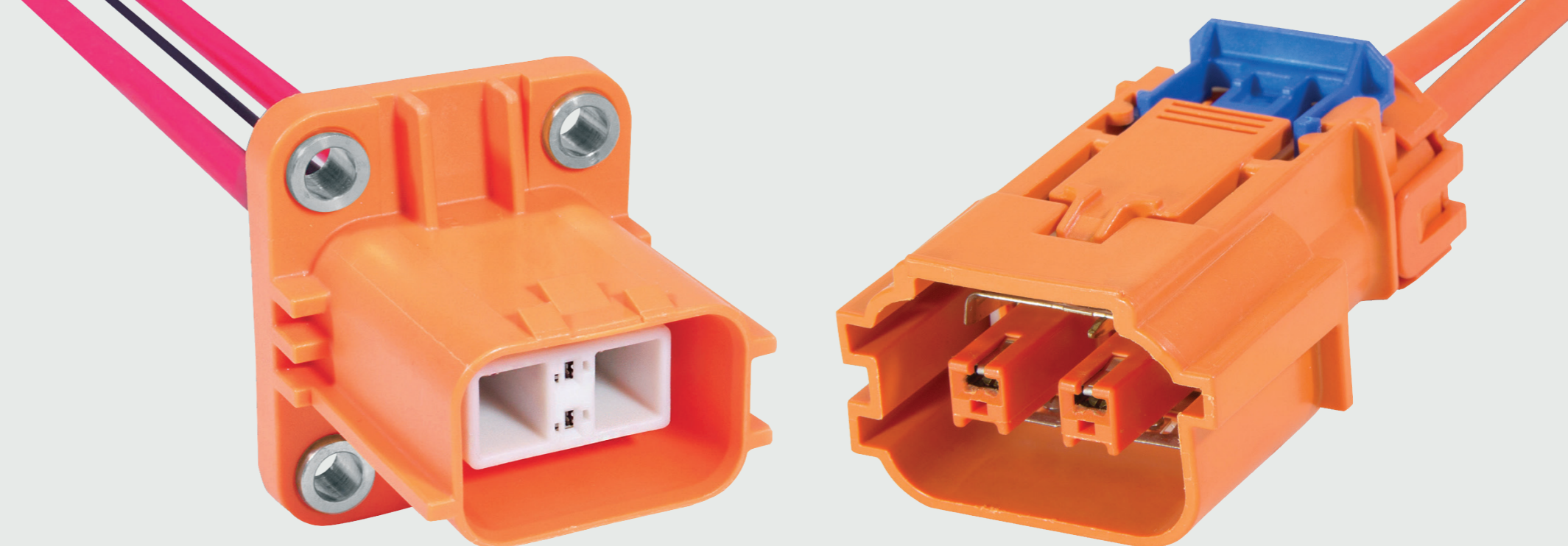

Application	Battery pack, DC / DC converter, Electric AC, TC heater, HV PDU, On-Board Charger (OBC)							
Product name	SHIELDPACK™ HV 280 SI 2 WAY	SHIELDPACK™ HV 280 SI 3 BAY HEADER	SHIELDPACK™ HV AK CLASS 1 2 WAY SI	SHIELDPACK™ HV AK CLASS 1 SMU	SHIELDPACK™ HV APEX280 SB	SHIELDPACK™ HV CTS280 SI	SHIELDPACK™ HV APEX280 4 WAY SI	SHIELDPACK™ HV CTS630 SI
Amperage at 85°C	40 A	40 A	32 A	32 A	40 A	40 A	50 A	50 A
Voltage	1000 V	1000 V	1000 V	1000 V	1000 V	1000 V	1000 V	1000 V
Orientation	90° 180°	180°	180°	180°	180°	180°	90° 180°	180°
# of ways (power)	2	2	2	2 & 3	2	4	4	2
HVIL	✓	✓	✓	✓	✓	✓	✓	×
Shielding	Individual	Individual	Individual	Multicore	Bundle	Individual	Individual	Individual
Vibration Class	V2	V2	V2	V2	V1	V1	V2	V2
Temperature Class	T3	T3	T4	T4	T3	T3	T3	T3
Sections power	2 - 5 mm ²	2 - 5 mm ²	2.5 - 4 mm ²	2.5 - 4 mm ²	2.5 - 6 mm ²	3 - 5 mm ²	2.5 - 6 mm ²	2 - 6 mm ²
Sections HVIL	0.5 mm ²	0.5 mm ²	0.35 - 0.75 mm ²	0.5 mm ²	0.5 - 0.75 mm ²	0.5 - 0.75 mm ²	0.22 - 0.35 mm ²	-
See Page	12 - 13	14 - 15	16 - 17	18 - 19	20 - 21	22 - 23	24 - 25	26 - 27



			Splicing accessory loads	On-Board Charger (OBC)					
Product name	SHIELDPACK™ HV630 HVIL SI	SHIELDPACK™ HV AK CLASS 2 2 WAY SMU	SHIELDPACK™ HV CTS630 4 WAY SI	SHIELDPACK™ HV CTS280/630 SI SPLICE	POWERPACK HV HES240 UI OBC	POWERPACK HV APEX280 UI OBC 3 WAY	POWERPACK HV APEX280 UI OBC 5 WAY	SHIELDPACK™ HV AK CLASS 2 5 WAY SMU	POWERPACK HV630 UI OBC
Amperage	60 A	55 A	60 A	40 A	32 A	40 A	40 A	55 A	40 / 80 A
Voltage	1000 V	1000 V	1000 V	1000 V	600 V	600 V	600 V	1000 V	1000 V
Orientation	180°	180°	180°	180°	180°	180°	180°	180°	180°
# of ways (power)	2	2	4	4	4	3	5	5	2
HVIL	✓	✓	×	✓	✓	✓	✓	✓	✓
Shielding	Individual	Multicore	Individual	Individual	No	No	No	Multicore	No
Vibration Class	V1	V2	V1	V1	V1	V1	V1	V2	V1
Temperature Class	T3	T4	T3	T3	T3	T3	T3	T4	T3
Sections power	3 - 6 mm ²	4 - 6 mm ²	3 - 6 mm ²	3 - 5 mm ²	3 - 6 mm ²	6 mm ²	6 mm ²	4 - 6 mm ²	6 - 12 mm ²
Sections HVIL	0.5 - 0.75 mm ²	0.5 - 0.75 mm ²	-	0.5 - 0.75 mm ²	0.75 - 1 mm ²	0.22 - 0.35 mm ²	0.22 - 0.35 mm ²	0.5 - 0.75 mm ²	0.75 - 1 mm ²
See Page	28 - 29	30 - 31	32 - 33	34 - 35	36 - 37	38 - 39	40 - 41	42 - 43	44 - 45

SHIELDPACK™

HV 280 SI 2 WAY

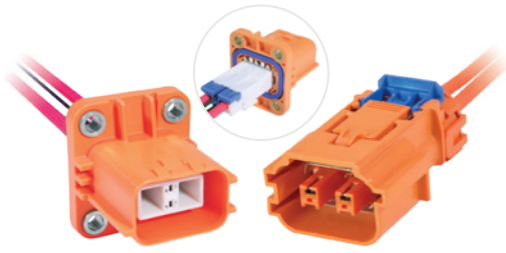

2 Way 180° Connection System with Pluggable Inner Connector

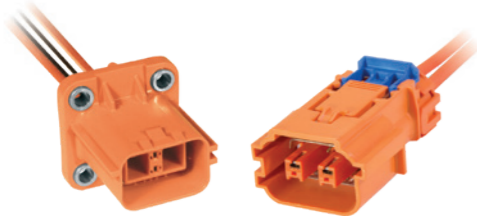

2 Way 180° Connection System without Pluggable Inner Connector

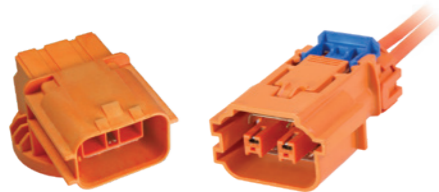

2 Way 90° Connection System

APPLICATIONS

- Battery pack
- DC / DC converter
- On-board charger (OBC)

BENEFITS

- Inner connector with TPA can be plugged into header during device assembly (on wire-to-device)
- Industry-leading vibration performance
- Field proven design used across electrification market

FEATURES

- Tool-less unmating system
- Finger proof/touch safe
- Aluminum compression bushings
- ISO cable compatible

AVAILABLE CONFIGURATIONS

Connector Type	Wire-to-device, wire-to-wire
Cable Exit Orientation	90°, 180°
Cable Range (mm²)	2 - 5 (power) 0.5 (HVIL)
Terminal Type	CTS 2.8, Metri-pack 2.8
# of Power Terminals	2
Shielding Type	Individual
HVIL	Shunt on female
Assembly Assurance	CPA/TPA
Number of Indexes	3 (180°), 1 (90°)

PERFORMANCE

TEMP RANGE

+125°C

-40°C

MAX CURRENT AT 85°C

40 A

MAX DC VOLTAGE

1000 V

VIBRATION LEVEL

V2

SEALING CLASS

IP67
IP6K9K

ELECTRICAL PROTECTION

IP2XB

Index	Header with pluggable inner connector		Header	Male inline connector	Mating connector	BOM
	Outer Header	Inner connector				
2 Way 180° Connection System						
101	35201196	15526394	33240508	33358013	33339283	1
102	35201197	15526395	33240509	33358014	33353455	
103	35201198	15526396	33240510	33358015	33353456	
2 Way 90° Connection System						
101	33341078	33341079			33339283	1

ASSOCIATED PARTS

Part number	Description	BOM
Header		
13753470	Metri-pack 2.8 male terminal 1 - 2 mm²	2
13753471	Metri-pack 2.8 male terminal 3 mm²	
13790534	Metri-pack 2.8 male terminal 4 - 5 mm²	
15432235	CTS HVIL female terminal 0.5 mm²	2
15526390	TPA	1
Inline Male		
13753470	Metri-pack 2.8 male terminal 1 - 2 mm²	2
13753471	Metri-pack 2.8 male terminal 3 mm²	
13790534	Metri-pack 2.8 male terminal 4 - 5 mm²	
13737699	Inner ferrule 3 mm²	2
33292550	Inner ferrule 5 mm²	
13737702	Outer ferrule 3 mm²	2
33292551	Outer ferrule 5 mm²	
15513453	Cable seal 3 mm²	1
15513451	Cable seal 5 mm²	1
13824779	TPA / strain relief 3 mm²	1
13888072	TPA / strain relief 5 mm²	1
Mating connector		
13882331	CTS 2.8 female terminal 3 - 5 mm²	2
13737699	Inner ferrule 3 mm²	2
33292550	Inner ferrule 5 mm²	
13737702	Outer ferrule 3 mm²	2
33292551	Outer ferrule 5 mm²	
15513453	Cable seal 3 mm²	1
15513451	Cable seal 5 mm²	1
13824779	TPA / strain relief 3 mm²	1
13888072	TPA / strain relief 5 mm²	1

DIMENSION MEASUREMENT SAMPLE

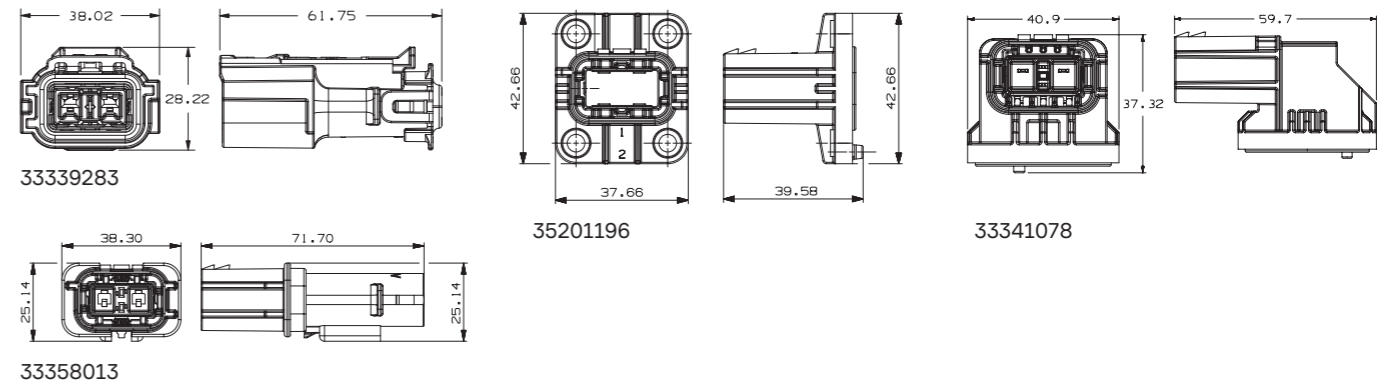

Part numbers, specifications, dimensions and performance data in this document are for general references only and are subject to change without notice. To verify product information, please contact an Aptiv representative.

SHIELDPACK™

HV 280 SI 3 BAY HEADER

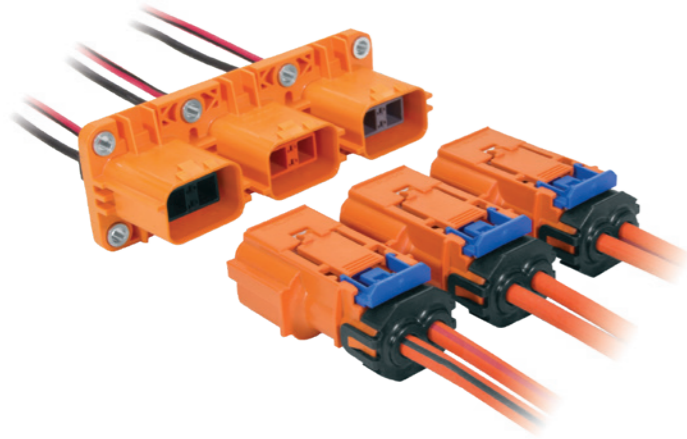

BENEFITS

- Answering to space constraints by having the 3 headers bolted together
- Inner connector with TPA can be plugged into header during device assembly (on wire-to-device)
- Industry-leading vibration performance
- Field proven design used across electrification market

FEATURES

- Tool-less unmating system
- Finger proof/touch safe
- Aluminum compression bushings
- ISO cable compatible

APPLICATIONS

- Battery pack
- DC / DC converter
- On-board charger (OBC)

AVAILABLE CONFIGURATIONS

Connector Type	Wire-to-device
Cable Exit Orientation	180°
Cable Range (mm²)	2 - 5 (power) 0.5 (HVIL)
Terminal Type	CTS 1.2, Metri-pack 2.8
# of Power Terminals	2
Shielding Type	Individual
HVIL	Shunt on female
Assembly Assurance	CPA/TPA
Number of Indexes	3

PERFORMANCE

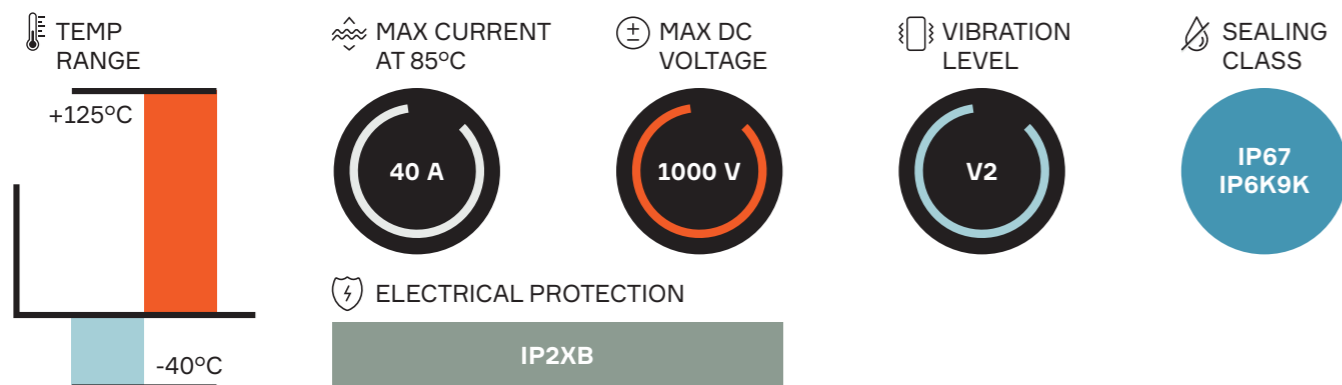

Index	Header outer	Header inner connector	Mating connector	BOM
103	33223976	15526396	33353456	1
104		15526397	33353457	
105		33137225	33353458	

ASSOCIATED PARTS

Part number	Description	BOM
Header		
13753470	Metri-pack 2.8 male terminal 1 - 2 mm²	2
13753471	Metri-pack 2.8 male terminal 3 mm²	
13790534	Metri-pack 2.8 male terminal 4 - 5 mm²	
15432235	CTS HVIL female terminal 0.5 mm²	2
15526390	TPA	1
Mating connector		
13882331	CTS 2.8 female terminal 3 - 5 mm²	2
13737699	Inner ferrule 3 mm²	2
33292550	Inner ferrule 5 mm²	
13737702	Outer ferrule 3 mm²	2
33292551	Outer ferrule 5 mm²	
15513453	Cable seal 3 mm²	1
15513451	Cable seal 5 mm²	1
13824779	TPA / strain relief 3 mm²	1
13888072	TPA / strain relief 5 mm²	1

DIMENSION MEASUREMENT SAMPLE

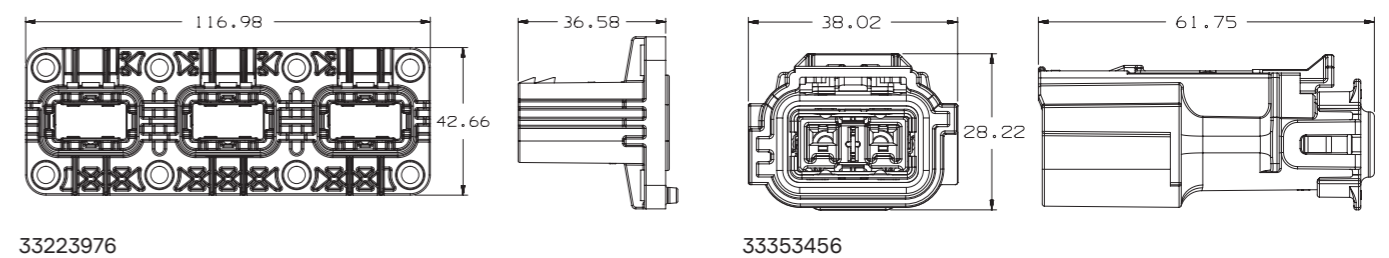

Part numbers, specifications, dimensions and performance data in this document are for general references only and are subject to change without notice. To verify product information, please contact an Aptiv representative.

SHIELDPACK™

HV AK CLASS 1 SI 2 WAY



BENEFITS

- High operating temperature
- High robustness against vibrations
- Standard AK interface
- Multiple layout & HVIL options offered with same interface (see also Multicore Shielded series)

FEATURES

- For applications with needs up to 40A
- Compliant to LV214 / LV215
- Patented squeezing fixture for enhanced anti-vibration performance
- Smaller package size than Multicore version

APPLICATIONS

- Air Conditioning
- PTC Heater
- On-board charger (OBC)
- DC/DC

AVAILABLE CONFIGURATIONS

Connector Type	Wire-to-device
Cable Exit Orientation	180°
Cable Range (mm ²)	3 / 4 / 5
Terminal Type	2.8 mm Blade Contact
# of Cavities	2
Shielding	Individual
HVIL	Shunt
Assembly Assurance	CPA
Number of Indexes	5

PERFORMANCE

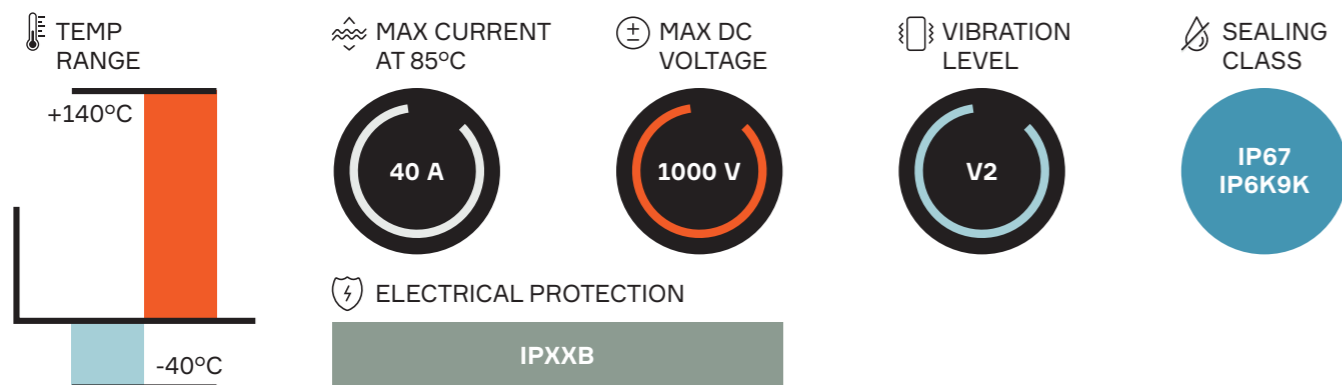

Index	Header connector	Mating Connector – Individually Shielded	BOM
A	35149836	35206206	1
B	35149837	35206207	
C	35149838	35206208	
D	35149839	35206209	
E	35149840	35206210	

ASSOCIATED PARTS

Part number	Description	BOM
Header		
35194900 Ag plated 33401022 Sn plated	DCS-2 2.8 Male Terminal	2
15540349 Ag plated 13580633 Sn plated	MTS-II 0.64 Female Terminal 0.25 - 0.35 mm ²	2
15540356 Ag plated 13580635 Sn plated	MTS-II 0.64 Female Terminal 0.5 - 0.75 mm ²	
35149868	TPA	1
Mating connector		
3 mm ² Cable 4 mm ² Cable 5 mm ² Cable		
13882331 Ag plated 13943933 Sn plated	CTS 2.8 Female Terminal	2
33522728 Ag plated 13780621 Sn plated	DCK 2.8 Female Terminal	
35226475 35230979 35230980	Outer Ferrule	2
35242858 35236785 35236786	Inner Ferrule	2
35240442 35230976 35206307	Cable Seal	1
35242833 35206310 35208801	Cable Strain Relief	1

DIMENSION MEASUREMENT SAMPLE

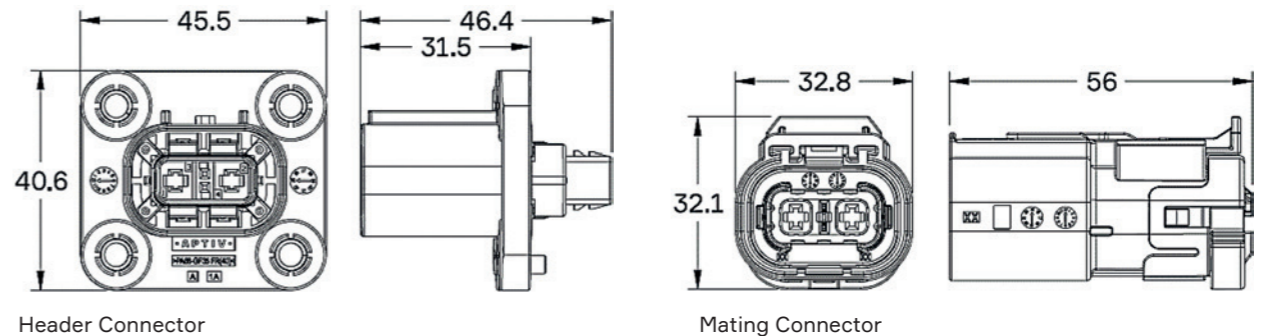

Part numbers, specifications, dimensions and performance data in this document are for general references only and are subject to change without notice. To verify product information, please contact an Aptiv representative.

SHIELDPACK™

HV AK CLASS 1 SMU 2 AND 3 WAY AK



BENEFITS

- Standard AK interface
- High vibrations and operating temperatures
- Multiple layouts & HVIL options in the same interface

FEATURES

- Designed according to AK interface specification and LV215 latest revision
- Finger proof/touch safe
- Multicore shielded cable for wiring simplification
- Fully interchangeable with other AK supplier sources

APPLICATIONS

- Battery pack
- DC / DC converter
- Electric AC
- PTC heater
- HV PDU
- On-board charger (OBC)

AVAILABLE CONFIGURATIONS

Connector Type	Wire-to-device
Cable Exit Orientation	180°
Cable Range (mm²)	2.5 - 4 (power) 0.5 - 0.75 (HVIL)
Terminal Type (mm)	2.8
# of Power Terminals	2
Shielding	Multicore
HVIL	Shunt on female or inline
Assembly Assurance	CPA/TPA
Number of Indexes	5

PERFORMANCE

TEMP RANGE

+140°C

-40°C

MAX CURRENT AT 85°C

32 A

MAX DC VOLTAGE

1000 V

VIBRATION LEVEL

V2

SEALING CLASS

**IP67
IP6K9K**

ELECTRICAL PROTECTION

IP2XB, IPXXD

Code	Header 2 way	Header 3 way	Mating outer housing	BOM
A	35149836	35149842	33372017	1
B	35149837	35149843	33372014	
C	35149838	35149844	33372016	
D	35149839	35149845	33372015	
E	35149840	35149846	35061103	

ASSOCIATED PARTS

Part number	Description	BOM		
		2 way, HVIL pass-through	2 way, HVIL shunt	3 way
Header				
35194900	DCS-2 2.8 male unsealed terminal 2.5-4 mm² Ag	2	2	3
35149868	TPA (Terminal Position Assurance) 2 way	1	1	-
35149869	TPA (Terminal Position Assurance) 3 way	-	-	1
15540356	MTS 0.64 female terminal 0.5-0.75 mm² Ag	2	2	-
Mating Connector				
13799603	CTS 2.8 female terminal 2.5 mm² Ag	2	2	3
13882331	CTS 2.8 female terminal 4 mm² Ag	-	-	-
33504709	HVIL male DuoTwin 0.64 0.5 mm² Ag	2	-	-
35174268	Spacer	1	1	1
35174446	Shielding	2	2	2
35174249	Cable strain relief 3 x 2.5 mm²	-	-	1
35174250	Cable seal 3 x 2.5 mm²	-	-	1
35174511	Inner housing 2 way	1	-	-
35174507	Cable strain relief 2 x 4.0 mm²	-	1	-
35174508	Cable seal 2 x 4.0 mm²	1	1	-
35174280	Inner ferrule	1	1	1
35174278	Outer ferrule	1	1	1
35174509	Inner housing sub-assembly	-	1	-
35174448	Inner housing 3 way	-	-	1
35174513	TPA (Terminal Position Assurance)	1	-	-
35174510	Cable strain relief 2 x 4.0 + 2 x 0.5 mm²	1	-	-

* Both DCK terminals and CTS terminals are compatible.

Component Kits**

Part number	Description (pass-through version)	Part number	Description (shunted version)
35122237	2 x 4 mm² + 2 x 0.5 mm² cable code A	33367712	2 x 4 mm² cable code A
35122238	2 x 4 mm² + 2 x 0.5 mm² cable code B	35122240	2 x 4 mm² cable code B
33367711	2 x 4 mm² + 2 x 0.5 mm² cable code C	35122241	2 x 4 mm² cable code C
35122239	2 x 4 mm² + 2 x 0.5 mm² cable code D	33367710	2 x 4 mm² cable code D
35086591	2 x 4 mm² + 2 x 0.5 mm² cable code E	35086590	2 x 4 mm² cable code E

** Available configurations with associated BOM (Bill Of Materials).

DIMENSION MEASUREMENT SAMPLE

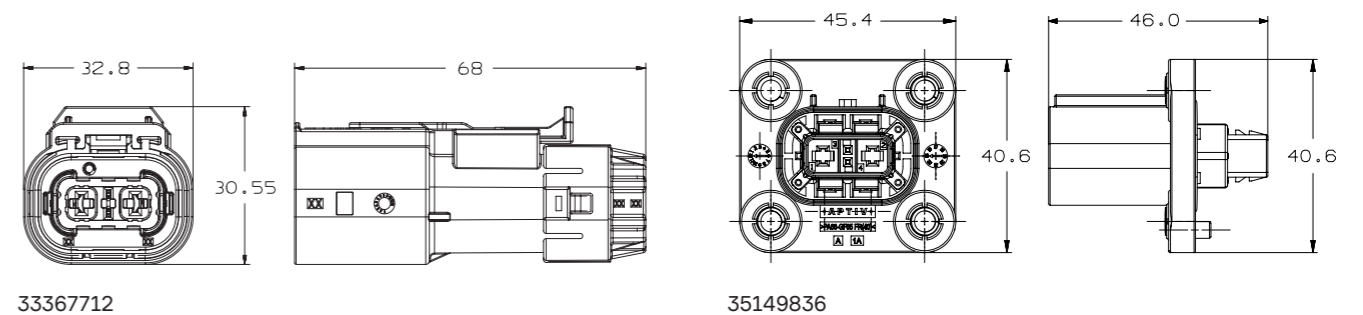

SHIELDPACK™

HV APEX280 SB 2 WAY

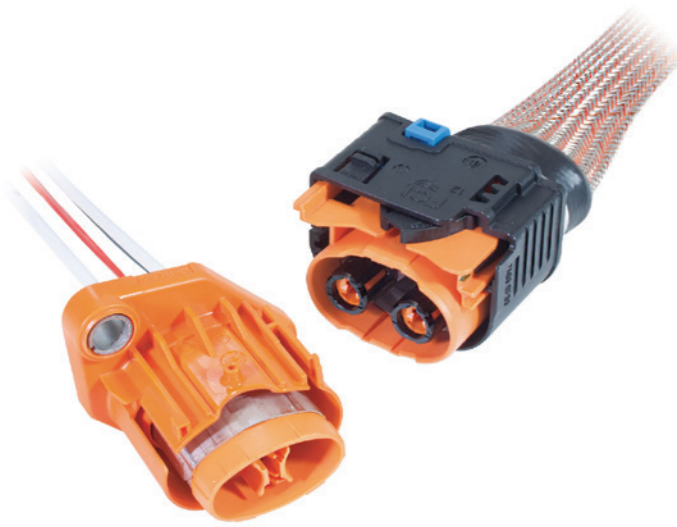

BENEFITS

- Two-stage disconnect for safe unmating
- Compact package with unique integrated electric interlock
- Header is sealed in both mated and unmated position

FEATURES

- Bundle shielding with external braid
- HVIL shunted in harness connector

APPLICATIONS

- Battery pack
- DC / DC converter
- On-board charger (OBC)

AVAILABLE CONFIGURATIONS

Connector Type	Wire-to-device
Cable Exit Orientation	180°
Cable Range (mm ²)	2.5 - 6 (power) 0.5 - 0.75 (HVIL)
Terminal Type	APEX® 2.8
# of Power Terminals	2
Shielding	Bundle
HVIL	Shunt on female
Assembly Assurance	CPA
Number of Indexes	2

PERFORMANCE

TEMP RANGE

+125°C

-40°C

MAX CURRENT AT 85°C

40 A

MAX DC VOLTAGE

1000 V

VIBRATION LEVEL

V1

SEALING CLASS

IP67
IP6K9K

ELECTRICAL PROTECTION

IP2XB

Index	Header connector	Mating connector	BOM
101	33511766	33517428	1
102	33511767	33511765	

ASSOCIATED PARTS

Part number	Description	BOM
Header		
15509074	APEX® 2.8 male terminal 2.5 mm ²	2
15516298	APEX® 2.8 male terminal 4 - 6 mm ²	
33511802	DCS2 1.5 male terminal gold-plated 0.22 - 0.35 mm ²	2
10779703	DCS2 1.5 male terminal gold-plated 0.5 - 1 mm ²	
Mating connector		
13627267	APEX® 2.8 female terminal 2.5 mm ²	2
10810733	APEX® 2.8 female terminal 4 - 6 mm ²	
Seals		
33512180	Header and mating: APEX® 2.8 female & male single wire seal 2.5 mm ²	2
33512175	Header and mating: APEX® 2.8 female & male single wire seal red 4 mm ²	
35289308	Header and mating: APEX® 2.8 female & male single wire seal 6 mm ²	
15441379	Header: DCS/DSQ 1.5 red single wire seal 0.22 - 0.5 mm ²	2
15441380	Header: DCS/DSQ 1.5 grey single wire seal 0.75 - 1 mm ²	

DIMENSION MEASUREMENT SAMPLE

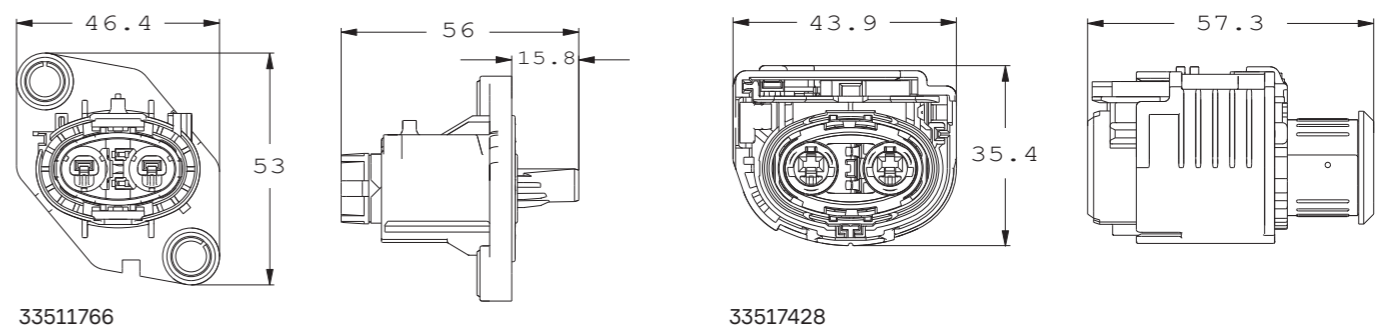

Part numbers, specifications, dimensions and performance data in this document are for general references only and are subject to change without notice. To verify product information, please contact an Aptiv representative.

SHIELDPACK™

HV CTS280 SI 4 WAY

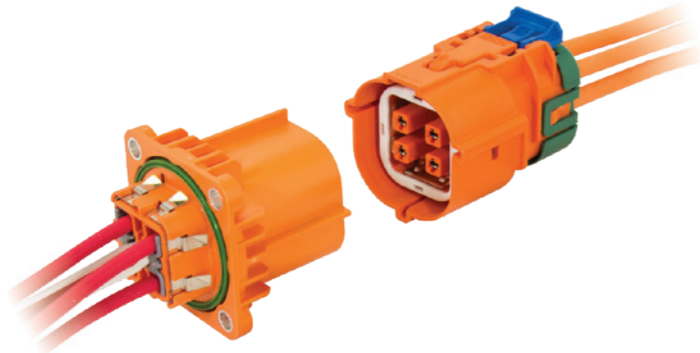

BENEFITS

- No mechanical assist needed for mating
- Compact system design with integrated HVIL
- Robust error-proof assembly and system mating

FEATURES

- Tool-less unmating system
- Finger proof/touch safe
- 4 power circuits
- Panel mount to device with face seal (on wire-to-device)
- Aluminum compression bushings
- Internal HVIL (shunted in harness connector)
- ISO cable compatible

APPLICATIONS

- Battery pack
- DC / DC converter
- On-board charger (OBC)

AVAILABLE CONFIGURATIONS

Connector Type	Wire-to-device
Cable Exit Orientation	180°
Cable Range (mm ²)	3 - 5 (power) 0.5 - 0.75 mm (HVIL)
Terminal Type	CTS 2.8
# of Power Terminals	4
Shielding	Individual
HVIL	Shunt on female
Assembly Assurance	CPA
Number of Indexes	2

PERFORMANCE

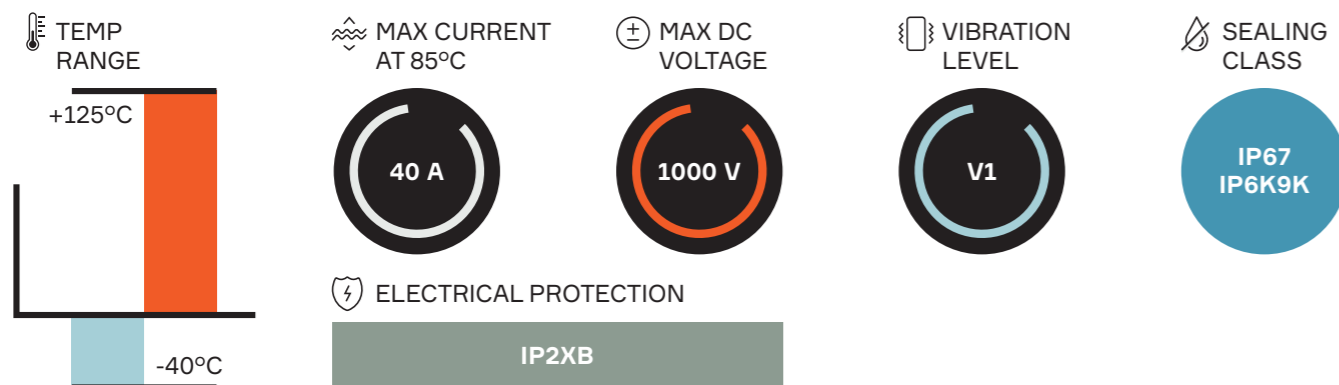

Index	Header outer	Header inner connector	Mating connector	BOM
101	35099959	35099976	33314147	1
102	35161787	35149737	33314148	

ASSOCIATED PARTS

Part number	Description	BOM
Header		
13597855	MTS 0.64 HVIL female terminal 0.5 - 0.75 mm	2
13753471	CTS 2.8 male terminal 3 - 5 mm ²	4
13790534	CTS 2.8 male terminal 4 - 5 mm ²	
33314145	TPA (Terminal Position Assurance)	2
Mating Connector		
13882331	CTS 2.8 female terminal 3 - 5 mm ²	4
13737699	Inner ferrule 3 mm ² ISO cable	4
33292550	Inner ferrule 5 mm ² ISO cable	
13737702	Outer ferrule 3 mm ² ISO cable	4
33292551	Outer ferrule 5 mm ² ISO cable	
35072736	Female mat seal 3 mm ²	1
35072735	Female mat seal 5 mm ²	
35072739	Mat seal retainer 3 mm ²	1
35072738	Mat seal retainer 5 mm ²	

DIMENSION MEASUREMENT SAMPLE

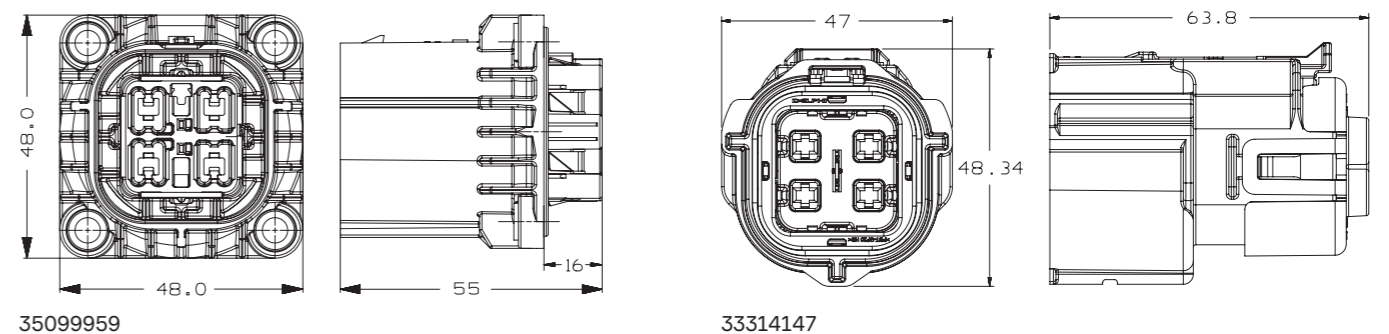

SHIELDPACK™

HV APEX280 SI 4 WAY



BENEFITS

- High endurance against vibration
- Compliant to LV standard

FEATURES

- 280 terminal system & 0.64 HVIL
- Flammability grade UL94 V0
- Sealing: IP6K9K , IP67, IPXXB, IPXXD (mated)

APPLICATIONS

- Electric AC
- HV Heater
- OBC/Auxiliary Devices

AVAILABLE CONFIGURATIONS

Connector Type	Wire-to-device
Cable Exit Orientation	90°/180°
Cable Range (mm ²)	2.5-6
Terminal Type	APEX® 2.8
# of Power Terminals	4
Shielding	Individual
HVIL	Shunt on female
Assembly Assurance	CPA/TPA
Number of Indexes	4
Header footprint 90deg (l*w*h)	54.8*50.9*54.7
Header footprint 180deg (l*w*h)	46*46*40.4

PERFORMANCE

TEMP RANGE

+125°C

-40°C

MAX CURRENT AT 85°C

50 A

MAX DC VOLTAGE

1000 V

VIBRATION LEVEL

V2

SEALING CLASS

IP67
IP6K9K

ELECTRICAL PROTECTION

IP2XB

CONNECTOR PART NUMBERS

Index	Header connector 90°	Header connector inner housing 90°	Header connector 180°	Header connector inner housing 180°	Mating connector	BOM
A	35607793	35607811	35607572	35607604	35607516	1
B	35607794	35607812	35607573	35607605	35607517	1
C	35607795	35607813	35607574	35607606	35607519	1
D	35607796	35607814	35607576	35607607	35607521	1

ASSOCIATED PARTS

Part number		Description	BOM			
Header 90°						
	10762803	APEX® 2.8 female terminal Sn plated unsealed 1.5 - 2.5 mm ²	4			
	33370369	APEX® 2.8 female terminal Ag plated unsealed 4 - 6 mm ²	4			
	13959131	CTS 1.2 female terminal	2			
Header 180°						
	33400512	APEX® 2.8 male terminal 4 - 6 mm ² unsealed, Ag plating	4			
	13959131	CTS 1.2 female terminal	2			
Mating Connector						
	2.5 mm ²	4 mm ²	5 mm ²	6 mm ²		
35663483	35607547	35607548	35607549		Inner Ferrule	4
35663486	35607551	35607553	35607554		Outer Ferrule	4
35663718	35607557	35607558	35607559		Cable seal	4
35663719	35607561	35607562	35607563		Cable retainer	4
	10762803	APEX® 2.8 female terminal Ag plated unsealed 1.5 - 2.5 mm ²				4
	33370369	APEX® 2.8 female terminal Ag plated unsealed 4 - 6 mm ²				4

DIMENSION MEASUREMENT SAMPLE

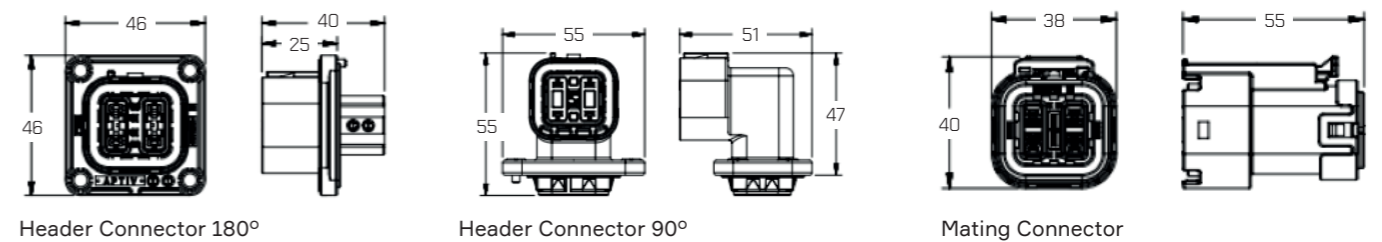

Part numbers, specifications, dimensions and performance data in this document are for general references only and are subject to change without notice. To verify product information, please contact an Aptiv representative.

SHIELDPACK™

HV CTS630 SI 2 WAY

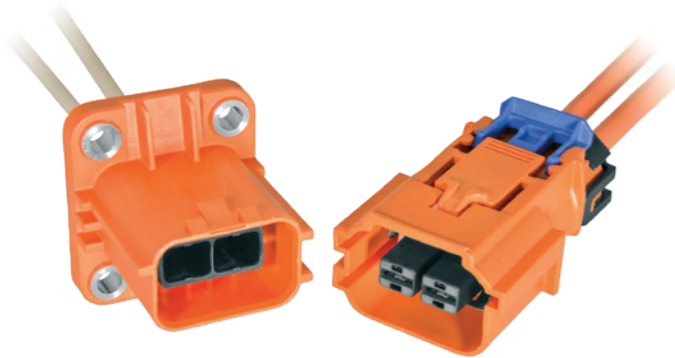

HV630 Header and Mating connector

BENEFITS

- Inner connector with TPA can be plugged into header during device assembly (on wire-to-device)
- Industry's most compact 630 2 way system
- Industry leading vibration performance
- External header housing is the same for the HV280 and HV630

FEATURES

- Tool-less unmating system
- Finger proof/touch safe
- Panel mount to device with face seal (on wire-to-device)
- Aluminum compression bushings
- ISO cable compatible
- Secondary terminal locking

APPLICATIONS

- Battery pack
- DC / DC converter
- On-board charger (OBC)

AVAILABLE CONFIGURATIONS

Connector Type	Wire-to-device, wire-to-wire
Cable Exit Orientation	180°
Cable Range (mm²)	3 - 6 (power)
Terminal Type	CTS 6.3
# of Power Terminals	2
Shielding Type	Individual
HVIL	None
Assembly Assurance	TPA (wire-to-device) CPA (wire-to-wire)
Number of Indexes	3 (wire-to-device) 3 (wire-to-wire)

PERFORMANCE

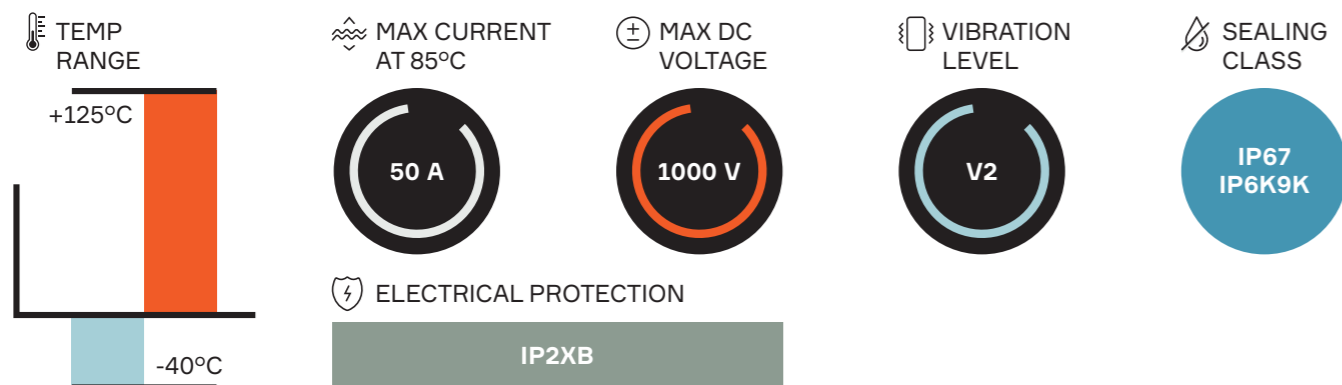

Index	Header outer	Header inner connector	Inline connector	Mating connector	BOM
101	35201196	35028833	35201706	35028839	1
102	35201197	35028834	35201707	35028840	
103	35201198	35028835	35201708	35028841	

ASSOCIATED PARTS

Part number	Description	BOM
Header		
33375907	4.8 Male terminal 3 - 6 mm²	2
35028830	TPA (Terminal Position Assurance)	1
Inline connector		
35063063	4.8 male terminal	2
Mating connector		
13984307	Female CTS 6.3 terminal 3 - 6 mm²	2
13737699	Inner ferrule 3 mm² cable	2
13737700	Inner ferrule 4 mm² cable	
33292550	Inner ferrule 5 mm² & 6 mm² cable	2
13737702	Outer ferrule 3 mm² & 4 mm² cable	
33292551	Outer ferrule 5 mm² & 6 mm² cable	1
13824779	Seal retainers 3 mm² & 4 mm² cable	
13888072	Seal retainers 5 mm² & 6 mm² cable	1
15513453	Cable seal 3 mm² cable	
15513452	Cable seal 4 mm² cable	
15513451	Cable seal 5 mm² & 6 mm² cable	

DIMENSION MEASUREMENT SAMPLE

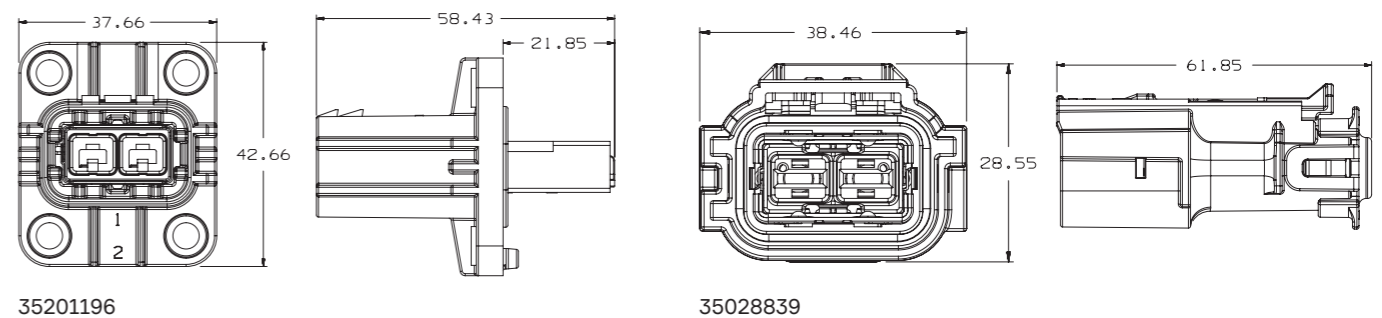

Part numbers, specifications, dimensions and performance data in this document are for general references only and are subject to change without notice. To verify product information, please contact an Aptiv representative.

SHIELDPACK™

HV630 HVIL SI 2 WAY

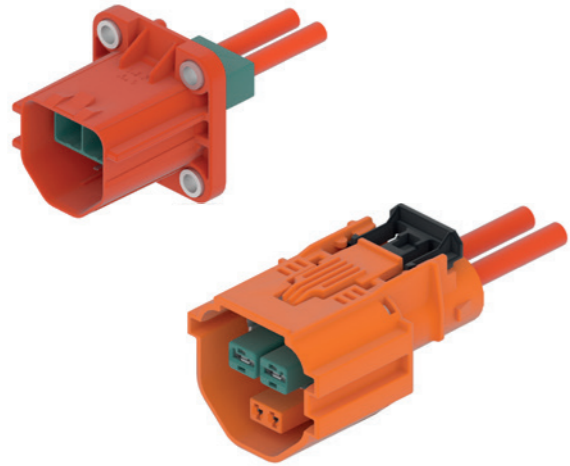

BENEFITS

- Inner connector with TPA can be plugged into header during device assembly (on wire-to-device)
- Industry leading vibration performance

FEATURES

- Tool-less unmating system
- Finger proof/touch safe
- Panel mount to device with face seal (on wire-to-device)
- Aluminum compression bushings
- ISO cable compatible
- Secondary terminal locking

APPLICATIONS

- Battery pack
- DC / DC converter
- On-board charger (OBC)
- Auxiliary loads

AVAILABLE CONFIGURATIONS

Connector Type	Wire-to-device
Cable Exit Orientation	180°
Cable Range (mm ²)	3 - 6
Terminal Type	CTS 6.3
# of Power Terminals	2
Shielding Type	Single conductor shielded cable
HVIL	Pass through / Shunt on header
Assembly Assurance	CPA
Number of Indexes	1

PERFORMANCE

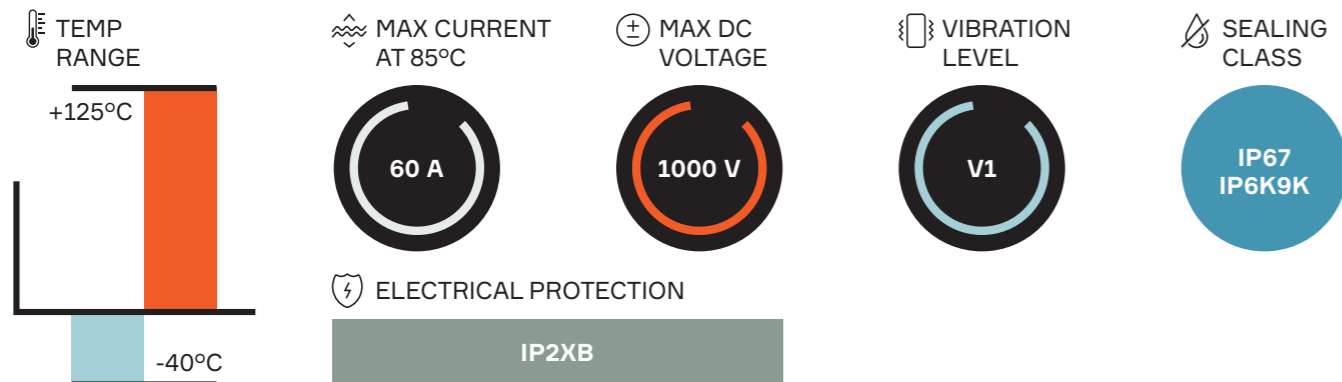

CONNECTOR PART NUMBERS

Code	Header connector	HVIL Type	Header inner connector	Mating connector	BOM
101	35447175	HVIL Pass Through	35327273	35578206	1
101	35372303	Shunt on Header			1

ASSOCIATED PARTS

Part number	Description	BOM
Header		
35028830	TPA (Terminal Position Assurance)	1
35446700*	4.8 Male Terminal 4 - 6 mm ²	2
15396712**	HVIL Male Terminal TTS 1.5, 0.5 - 0.75 mm ²	2
Mating connector		
13824779	Secondary Lock	1
15513451	Seal Cable 5 - 6 mm ²	1
13984307	CTS 6.3 Female Terminal 4 - 6 mm ²	2
15432210	Female HVIL 150 Terminal 0.5 - 1 mm ²	2
35371916	HVIL Cover	1
33292551	Outer Ferrule 5 - 6mm ²	2
33292550	Inner Ferrule 5 - 6mm ²	2

* Non Aptiv terminal, please consult us.

** Only used for HVIL Pass Through Header

DIMENSION MEASUREMENT SAMPLE

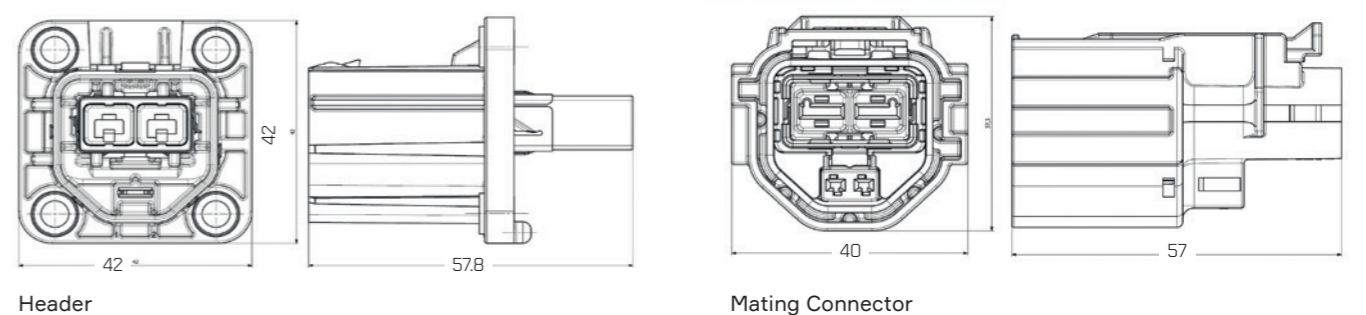

SHIELDPACK™

HV AK CLASS 2 SMU 2 WAY

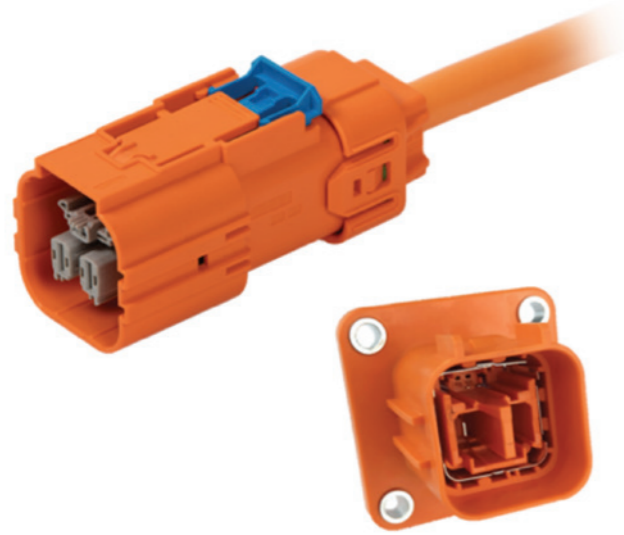

BENEFITS

- High operating temperature
- High robustness against vibrations
- Standard AK interface
- No mechanical assist required thanks to low insertion force

FEATURES

- For applications with needs up to 55A
- Compliant to LV214 / LV215
- Tool-less mating & un-mating system
- Patented squeezing fixture for enhanced anti-vibration performance

APPLICATIONS

- Air Conditioning
- PTC Heater
- On-board charger (OBC)
- DC/DC

AVAILABLE CONFIGURATIONS

Connector Type	Wire-to-device
Cable Exit Orientation	180°
Cable Range (mm ²)	4 - 6
Terminal Type	6.3 mm Blade Contact
# of Cavities	2
Shielding	Multicore
HVIL	Shunt
Assembly Assurance	CPA
# of Code Indexes	2

PERFORMANCE

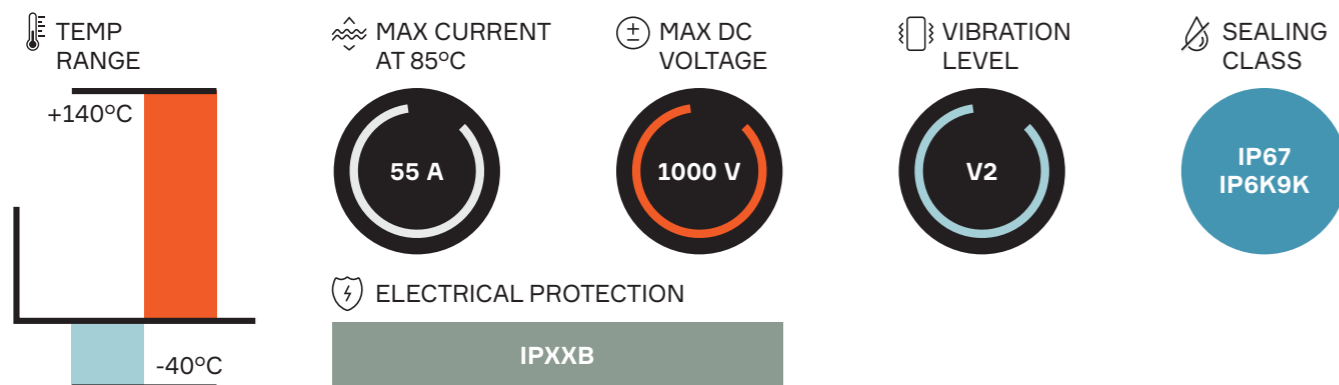

Index	Header Connector	Mating Connector	BOM
A	35116365	35230055	1
B	35169586	35230056	

Additional codes are offered on demand. Contact an Aptiv representative for details.
Header connector can be customized for outlet and assembled HVIL harness. Contact Aptiv engineering for details.

ASSOCIATED PARTS

Part number	Description	BOM
Header connector		
13952636*	1.2 Male Terminal 0.5 - 0.75 mm ²	2
Mating connector		
2 × 4 mm ² Cable	2 × 6 mm ² Cable	2
13984302 Ag plated	13984307 Ag plated	
13976101 Sn plated	13976102 Sn plated	1
35196906	HVIL Shunt Harness	1
35174280	35200703	1
35200704	35200705	2
35200706	35200707	1
35230073	Inner Housing	1
35200700	35200701	1
35230068	35230069	1
	CTS 6.3 Female Terminal	
	Inner Ferrule	
	Outer Ferrule	
	EMC Shield	
	Cable Seal	
	Cable Strain Relief	

* Non Aptiv terminal, please consult us.

DIMENSION MEASUREMENT SAMPLE

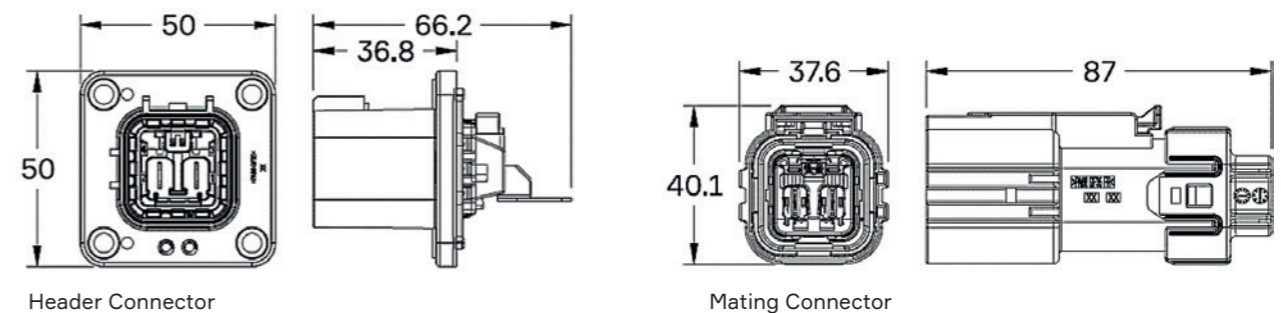

SHIELDPACK™

HV CTS630 SI 4 WAY



BENEFITS

- Inner connector with TPA can be plugged into header during device assembly (on wire-to-device)
- Industry leading vibration performance
- External header housing is the same for the HV280 and HV630

FEATURES

- Tool-less unmating system
- Finger proof/touch safe
- Panel mount to device with face seal (on wire-to-device)
- Aluminum compression bushings
- ISO cable compatible
- Secondary terminal locking

APPLICATIONS

- Battery pack
- DC / DC converter
- On-board charger (OBC)
- Auxiliary loads

AVAILABLE CONFIGURATIONS

Connector Type	Wire-to-device
Cable Exit Orientation	180°
Cable Range (mm ²)	5
Terminal Type	CTS 6.3
# of Power Terminals	4
Shielding Type	Single conductor shielded cable
HVIL	None
Assembly Assurance	CPA
Number of Indexes	1

PERFORMANCE

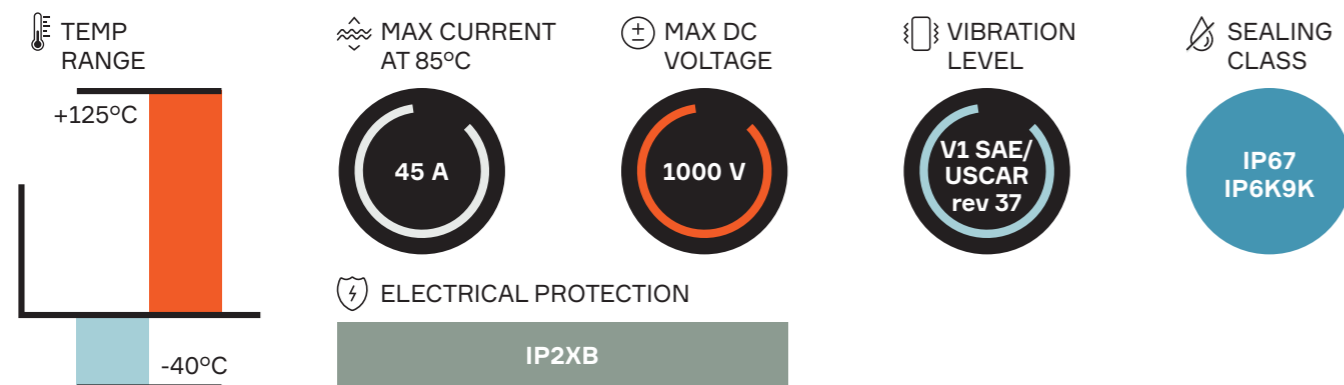

Index	Header outer	Header inner connector	Mating connector	BOM
101	33300632	35448103	35448131	1

ASSOCIATED PARTS

Part number	Description	BOM
Header		
35448129	TPA	1
35446700	CTS 6.3 Male Terminal 5 mm ²	4
Mating connector		
13984307	CTS 6.3 Female Terminal 5 mm ²	4
33292550	Inner Ferrule 5 mm ² ISO cable	4
33292551	Outer Ferrule 5 mm ² ISO cable	4
35072735	Female mat seal 5 mm ²	1
35072738	Mat Seal Retainer 5 mm ²	1

DIMENSION MEASUREMENT SAMPLE

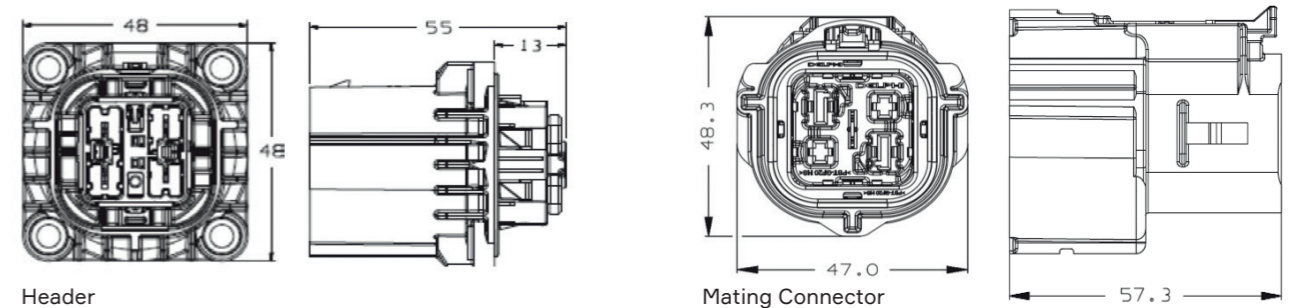

Part numbers, specifications, dimensions and performance data in this document are for general references only and are subject to change without notice. To verify product information, please contact an Aptiv representative.

SHIELDPACK™

HV CTS280/630 SI SPLICE 4 WAY

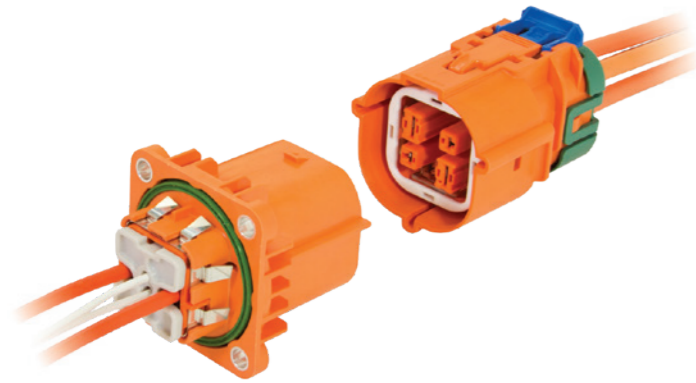

BENEFITS

- Removes splices from the wiring harness and integrates splicing capabilities into connector
- No mechanical assist needed for mating

FEATURES

- Tool-less unmating system
- Finger proof/touch safe
- Panel mount to device with face seal
- Aluminum compression bushings
- Internal HVIL (shunted in harness connector)
- ISO cable compatible

APPLICATIONS

Splicing accessory loads

AVAILABLE CONFIGURATIONS

Connector Type	Wire-to-device
Cable Exit Orientation	180°
Cable Range (mm ²)	3 - 5 (power) 0.5 - 0.75 (HVIL)
Terminal type	CTS 2.8(2) / 6.3(2)
# of Power Terminals	4
Shielding	Individual
HVIL	Shunt on female
Assembly Assurance	CPA
Number of Indexes	2

PERFORMANCE

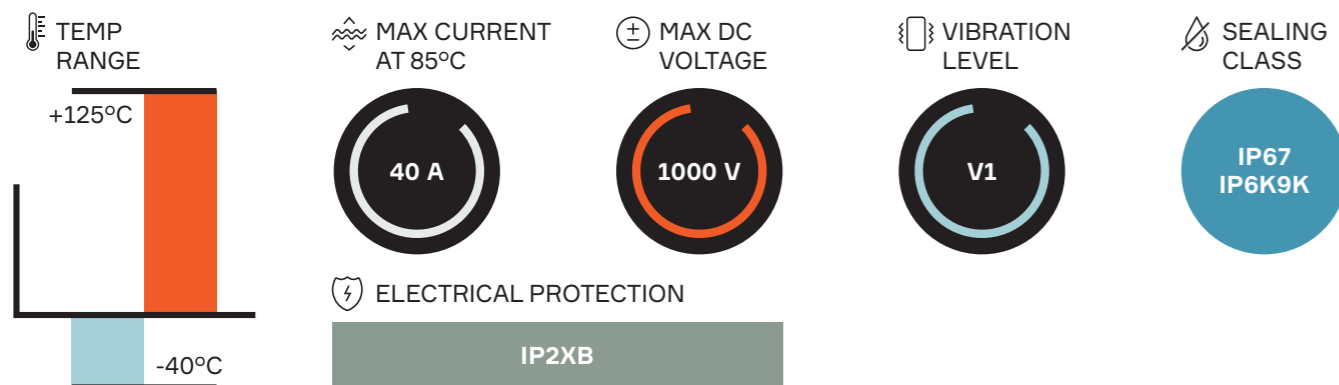

Index	Header outer	Header inner connector	Mating connector	BOM
101	33300632	33311166	33300634	1
102	33300633	33311167	33300635	

ASSOCIATED PARTS

Part number	Description	BOM
Header		
13597855	MTS 0.64 HVIL female terminal 0.5 - 0.75 mm ²	2
33299800	630/280 male terminal 3 - 5 mm ²	2
33299799	TPA (Terminal Position Assurance)	2
Mating Connector		
13882331	CTS 2.8 female terminal 3 - 5 mm ²	2
13984302	CTS 6.3 female terminal 2.5 - 4 mm ²	2
13984307	CTS 6.3 female terminal 4 - 6 mm ²	
13737699	Inner ferrule 3 mm ² ISO cable	4
33292550	Inner ferrule 5 mm ² ISO cable	
13737702	Outer ferrule 3 mm ² ISO cable	4
33292551	Outer ferrule 5 mm ² ISO cable	
35072736	Female mat seal 3 mm ²	1
35072735	Female mat seal 5 mm ²	
35072739	Mat seal retainer 3 mm ²	1
35072738	Mat seal retainer 5 mm ²	

APPLICATION GUIDE

Power circuits shown, two sets of 2 in x 1 out

Application Guide for Aptiv 4W CTS 630/280 Shielded Connection
Typical Application - * Load Current Guidance

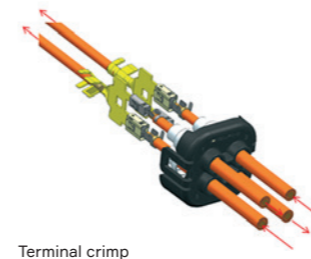

Terminal crimp wings are shown un-crimped.

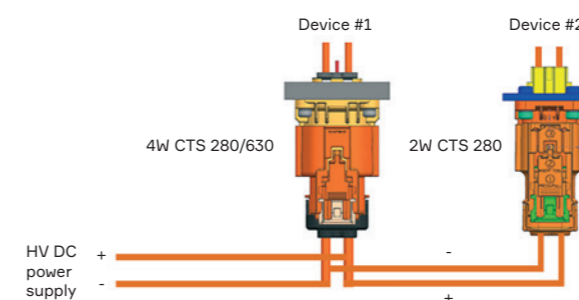

* Typical steady state currents with 5 mm² cable on all circuits

Input from DC power supply: 40 - 45 A
Current to Device #1: ≤ 40 A
Current to Device #2: ≤ 30 A

* Connector current ratings in vehicle applications will be affected by multiple factors including device heating, harness coverings, and device duty cycles. Please review application details with Aptiv Product Engineering for verification of current carrying capability.

DIMENSION MEASUREMENT SAMPLE

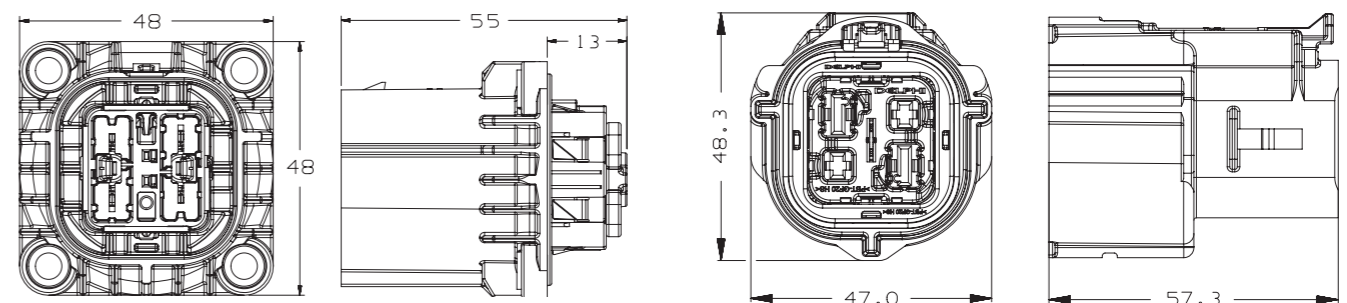

33300632

33300634

POWERPACK

HV HES240 UI OBC 4 WAY



BENEFITS

- Field proven technology widely used across electrification market
- Configurable for both 1-phase and 3-phase applications
- Compact packaging

FEATURES

- Finger proof/touch safe
- Capability for 4 power circuits and 2 signal circuits
- Unshielded system with terminal spacing for HV applications
- One-stage locking system with CPA
- Aluminum compression bushings

APPLICATIONS

On-board charger (OBC)

AVAILABLE CONFIGURATIONS

Connector Type	Wire-to-device, wire-to-wire
Cable Exit Orientation	180°
Cable Range (mm ²)	3 - 6 (power) 0.75 - 1 (HVIL)
Terminal Type	HES 1.0 (signal) HES 2.4 (power)
# of Power Terminals	4 (2 signal terminals)
Shielding Type	Unshielded
HVIL	None
Assembly Assurance	CPA
Number of Indexes	2

PERFORMANCE

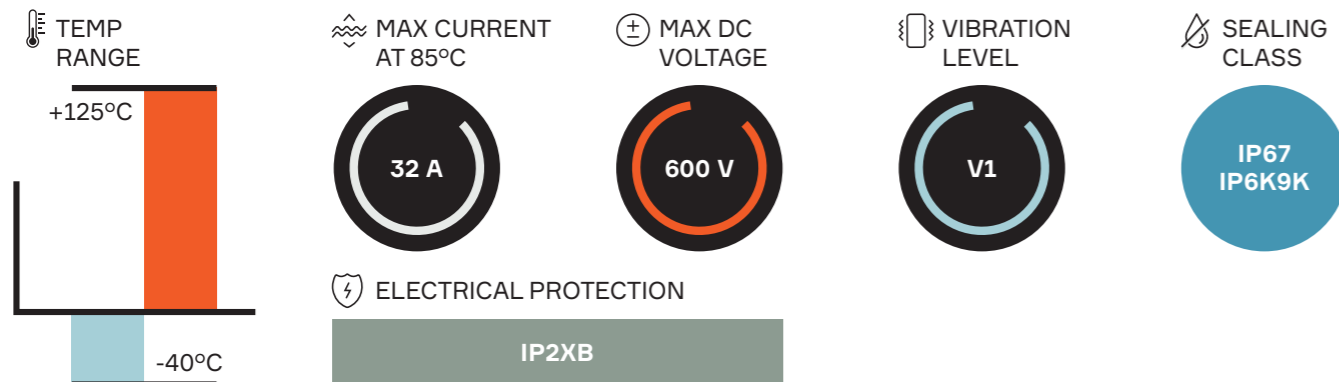

6 Way Device Connection System

Header connector	Mating connector		BOM
	16A	32A	
33229378	13879051 (2+2)	13879048 (2+2)	1
	15525754 (3+0)	15525753 (3+0)	
	13879050 (3+2)	13879047 (3+2)	
	13879049 (4+2)	13879046 (4+2)	

6 Way Inline Connection System

Male inline 16A	Male inline 32A	Mating connector	
		16A	32A
13990593 (2+2)	13990590 (2+2)	13879051 (2+2)	13879048 (2+2)
13990591 (4+2)	13990588 (4+2)	13879049 (4+2)	13879046 (4+2)

ASSOCIATED PARTS

Part number	Description	BOM
Header / Male inline		
13711549	1.0 HES gold-plated 0.75 - 1 mm ²	2 or 4
13783283	2.4 HES gold-plated 2 - 3 mm ²	2, 3, or 4
13783284	2.4 HES gold-plated 4 - 6 mm ²	
Mating connector		
13711549	1.0 HES gold-plated 0.75 - 1 mm ²	2 or 4
13955307	2.4 HES gold-plated 2 - 3 mm ²	2, 3, or 4
13955308	2.4 HES gold-plated 4 - 6 mm ²	

DIMENSION MEASUREMENT SAMPLE

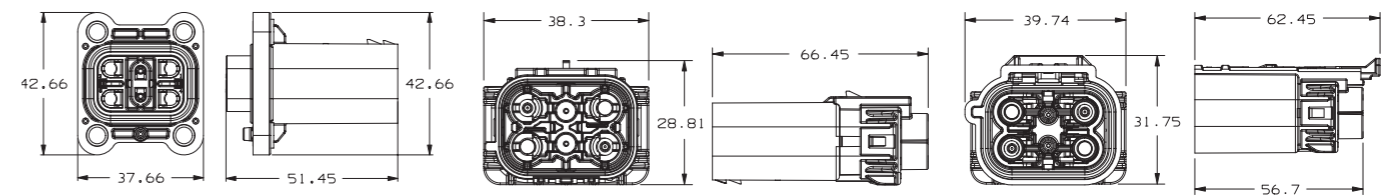

33229378

13990590

13879048*

* Female connector is compatible with both device & inline male connectors.

Part numbers, specifications, dimensions and performance data in this document are for general references only and are subject to change without notice. To verify product information, please contact an Aptiv representative.

POWERPACK

HV APEX280 UI OBC 3 WAY

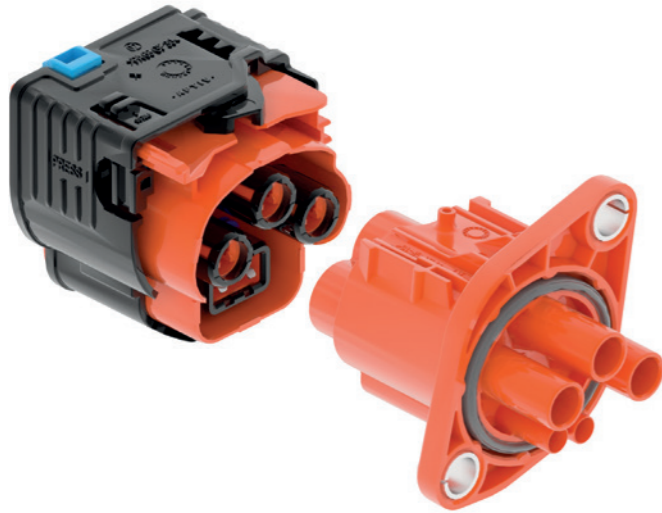

BENEFITS

- Optimized for 40A on-board charging solutions using 6 mm² cable range
- Robust and field proven APEX[®] 2.8 terminal technology
- Best in class safety and ergonomics in a compact package

FEATURES

- Compact two-piece design
- Robust connection: 3.9G vibration, 125°C temp range
- Easy mating ErgoMate™ system
- HVIL shunt on female connector

AVAILABLE CONFIGURATIONS

Connector Type	Wire-to-device
Cable Exit Orientation	180°
Cable Range (mm ²)	6
Terminal Type	APEX [®] 2.8
# of Power Terminals	3
Shielding Type	Unshielded
HVIL	Shunt on female
Assembly Assurance	CPA
Number of Indexes	1

APPLICATIONS

Inlet LV, On-board charger (OBC)

PERFORMANCE

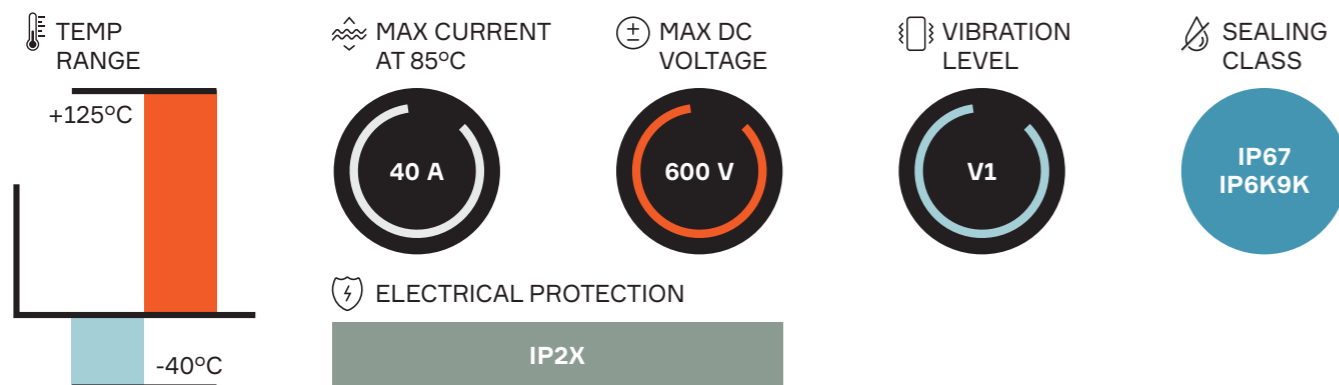

Header connector	Mating connector	BOM
35328058	35328072	1

ASSOCIATED PARTS

Part number	Description	BOM
Header		
15516298	APEX [®] 2.8 male tinned terminal 4 - 6 mm ²	3
33511802	DCS2 1.5 male terminal gold-plated 0.22 - 0.35 mm ²	2
10779703	DCS2 1.5 male terminal gold-plated 0.5 - 1 mm ²	2
Mating connector		
10810733	APEX [®] 2.8 female tinned terminal 4 - 6 mm ²	3
Seals		
15324981	Single wire seal blue (for JASO wire: EEX, EEHX, EEHX-BSX)	6
12186636	Single wire seal white (for ISO thin wall cable)	6
15441379	Single wire seal red 0.35 - 0.5 mm ²	2
15441380	Single wire seal grey 0.75 - 1 mm ²	2
35453673	Protective cover	1

DIMENSION MEASUREMENT SAMPLE

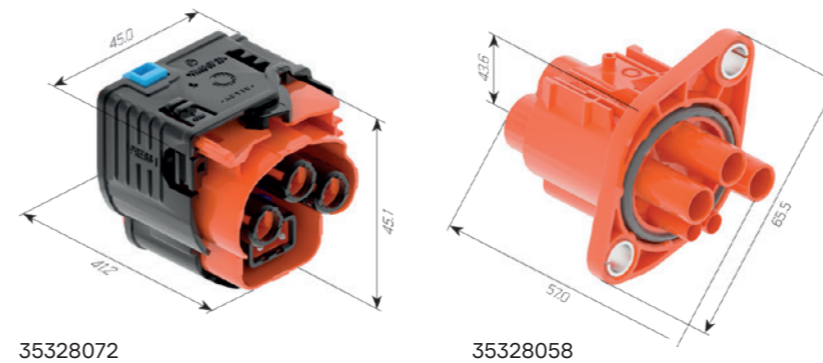

Part numbers, specifications, dimensions and performance data in this document are for general references only and are subject to change without notice. To verify product information, please contact an Aptiv representative.

POWERPACK

HV APEX280 UI OBC 5 WAY



BENEFITS

- Optimized for 40A on-board charging solutions using 6 mm² cable range
- Robust and field proven APEX[®] 2.8 terminal technology
- Best in class safety and ergonomics in a compact package

FEATURES

- Compact two-piece design
- Robust connection: 3.9G vibration, 125°C temp range
- Easy mating ErgoMate™ system
- HVIL shunt on female connector

AVAILABLE CONFIGURATIONS

Connector Type	Wire-to-device
Cable Exit Orientation	180°
Cable Range (mm ²)	6
Terminal Type	APEX [®] 2.8
# of Power Terminals	5
Shielding Type	Unshielded
HVIL	Shunt on female
Assembly Assurance	CPA
Number of Indexes	1

APPLICATIONS

Inlet LV, On-board charger (OBC)

PERFORMANCE

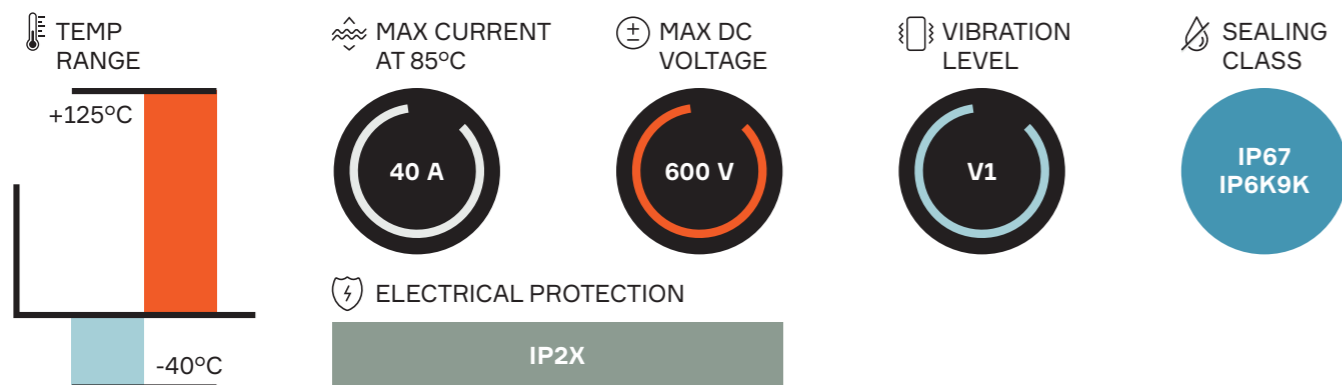

Header connector	Mating connector	BOM
35329007	35329023	1

ASSOCIATED PARTS

Part number	Description	BOM
Header		
15516298	APEX [®] 2.8 male tinned terminal 4 - 6 mm ²	5
33511802	DCS2 1.5 male terminal gold-plated 0.22 - 0.35 mm ²	2
10779703	DCS2 1.5 male terminal gold-plated 0.5 - 1 mm ²	
Mating connector		
10810733	APEX [®] 2.8 female tinned terminal 4 - 6 mm ²	5
Seals		
15324981	Single wire seal blue (for JASO wire: EEX, EEHX, EEHX-BSX)	5
12186636	Single wire seal white (for ISO thin wall cable)	5
15441379	DCS 1.5 red single wire seal 0.35 - 0.5 mm ²	2
15441380	DCS 1.5 grey single wire seal 0.75 - 1 mm ²	
35453676	Protective cover	1

DIMENSION MEASUREMENT SAMPLE

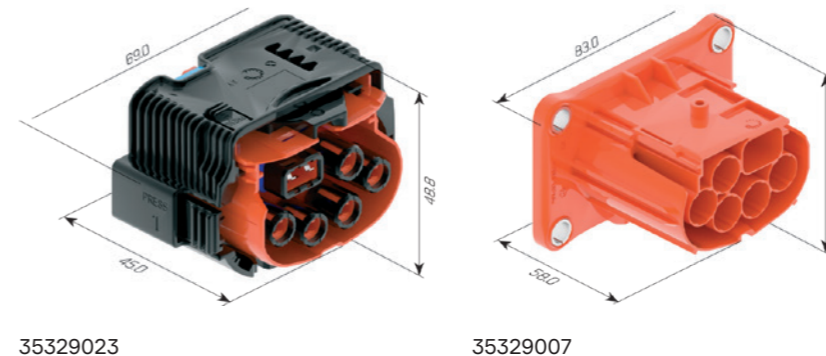

Part numbers, specifications, dimensions and performance data in this document are for general references only and are subject to change without notice. To verify product information, please contact an Aptiv representative.

SHIELDPACK™

HV CLASS 2 SMU 5 WAY



BENEFITS

- High operating temperature
- High robustness against vibrations
- Standard AK interface
- Compatible with various multicore cables

FEATURES

- For applications with needs up to 55A
- Compliant to LV214 / LV215
- Tool-less mating & un-mating system
- Patented squeezing fixture for enhanced anti-vibration performance
- Variant header connectors offered with pin-blade, terminal or busbar for power and harness solutions for HVIL

APPLICATIONS

- Air Conditioning
- PTC Heater
- On-board charger (OBC)
- DC/DC

AVAILABLE CONFIGURATIONS

Connector Type	Wire-to-device
Cable Exit Orientation	180°
Cable Range (mm²)	4 - 6
Terminal Type	6.3 mm Blade Contact
# of Cavities	3 / 4 / 5
Shielding	Multicore
HVIL	Shunt
Assembly Assurance	CPA
# of Code Indexes	1

PERFORMANCE

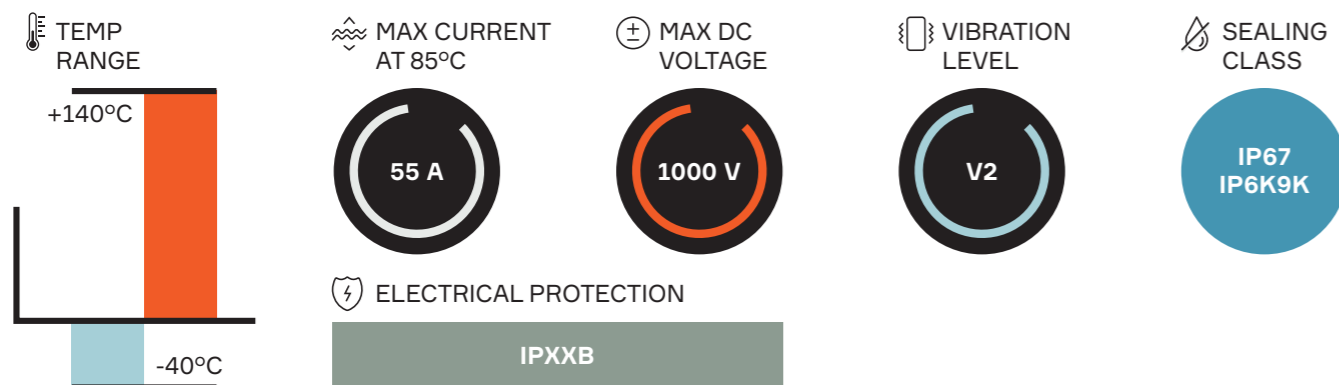

Index	Header Connector			Mating Connector	BOM
	Normal	Pin-Header Type	Busbar Type		
A	35235657	35153844	35425303	35200288	1

Additional codes are offered on demand. Contact an Aptiv representative for details.
Header connector can be customized for outlet and assembled HVIL harness. Contact Aptiv engineering for details.

ASSOCIATED PARTS

Part number		Description	BOM	
Header Connector – Normal (Crimp Terminals)				
35244766		APT 6.3 Male Terminal 4 - 6 mm²	2	
13952636		1.2 Male Terminal* 0.5 - 0.75 mm²	2	
35200302		HVIL Lock	1	
35245734		TPA	1	
Mating connector				
3 × 4 mm² Cable	4 × 4 mm² Cable	5 × 6 mm² Cable		
13984302 Ag plated 13976101 Sn plated		13984307 Ag plated 13976102 Sn plated	CTS 630 Female Terminal	3 - 5
35196906		CTS 1.2 Terminal HVIL Shunt Harness		1
35071844	35199785	35075633	Inner Ferrule	1
35071848	35199786	35075638	Outer Ferrule	1
35071846	35199766	35199476	EMC Shield	2
35200301		Inner Housing		1
35200302		TPA		1
35196896	35199782	35073658	Cable Seal	1
35196892	35170510	35200299	Cable Strain Relief	1

Also applicable with 2 × 6 mm² / 3 × 6 mm² / 4 × 6 mm² and 5 × 4 mm² cables. Contact an Aptiv representative for details.

* Non Aptiv terminal, please consult us

DIMENSION MEASUREMENT SAMPLE

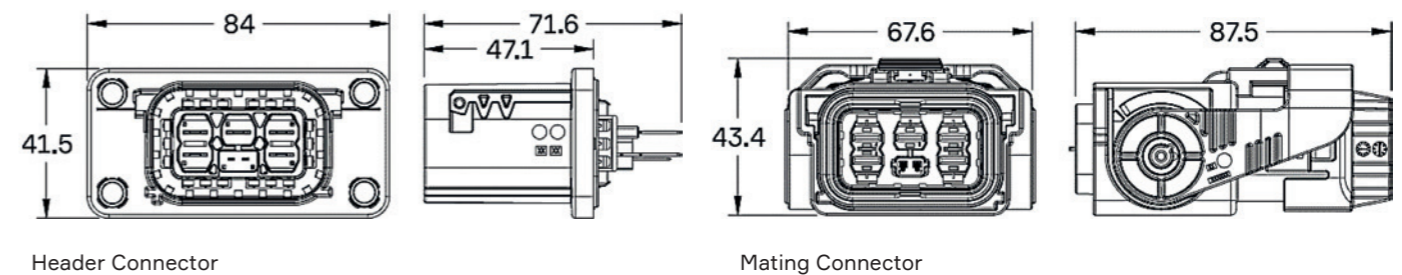

POWERPACK

HV630 UI OBC 2 WAY

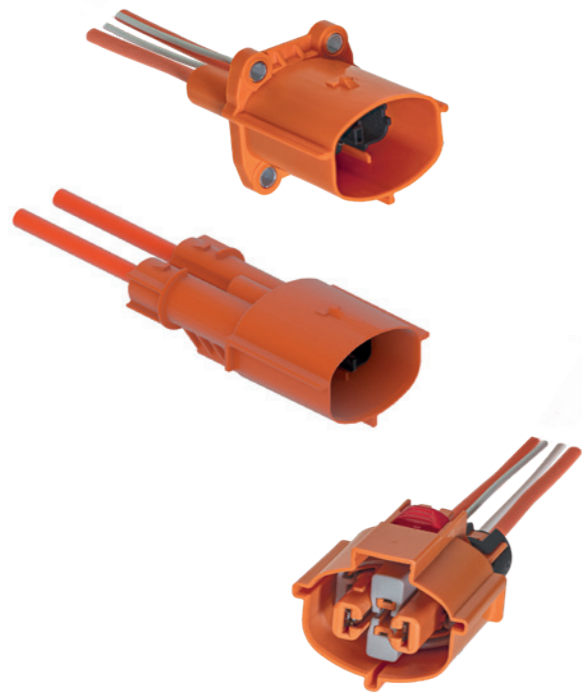

BENEFITS

- Inner connector with TPA can be plugged into header during device assembly (on wire-to-device)
- Industry leading vibration performance
- External header housing is the same for the HV280 and HV630

FEATURES

- Tool-less unmating system
- Finger proof/touch safe
- Panel mount to device with face seal (on wire-to-device)
- Aluminum compression bushings
- ISO cable compatibility
- Secondary terminal locking

APPLICATIONS

On-board charger (OBC)

AVAILABLE CONFIGURATIONS

Connector Type	Wire-to-device, wire-to-wire
Cable Exit Orientation	180°
Cable Range (mm ²)	6 - 12
Terminal Type	6.3 Terminal
# of Power Terminals	2 power
Shielding Type	Unshielded
HVIL	2 Signal cables
Assembly Assurance	CPA
Number of Indexes	3

PERFORMANCE

TEMP RANGE

+125°C

-40°C

MAX CURRENT AT 85°C

40 / 80 A

MAX DC VOLTAGE

1 000 V

VIBRATION LEVEL

V1

SEALING CLASS

IP67
IP6K9K

ELECTRICAL PROTECTION

IP2XB

CONNECTOR PART NUMBERS

Index	Header connector 80 A	Header connector 40 A Sealed even unmated	Inline Male Connector 80 A	Mating connector	BOM
101	35197119	35472532	35197170	35197127	1
102	35197120	-	35197171	35197129	1
103	-	-	35312616	35197131	1

ASSOCIATED PARTS

Part Number	Description	BOM
Header 80 A	Header 40 A Sealed even unmated	
35197125	35472597	TPA
13964786		OCS 1.5 Male Terminal sealed 0.75 - 1 mm ²
13834623		Cable Seal OCS 1.5, 0.75 - 1 mm ²
35135145*	-	6.3 Male Terminal
-	33386364	APEX® Male terminal 6.3 for 6 mm ²
-	10810380	Cable Seals - APEX® 6.3 for 6 mm ²
Inline connector		
35197125		Inner Connector
35197158		Cable Seal 8 mm ²
35197159		Cable Seal 10 mm ²
35197160		Cable Seal 12 mm ²
35197162		Retainer - Cable Seal 8 mm ²
35197163		Retainer - Cable Seal 10 & 12 mm ²
13964786		OCS 1.5 Male Terminal sealed 0.75 - 1 mm ²
13834623		Cable Seal OCS 1.5 0.75 - 1 mm ²
35135145*		6.3 Male Terminals
Mating connector		
35171862*		6.3 Female Terminals crimp version 6 - 10 mm ²
35116544*		6.3 Female Terminals Weld to Wire option
35406662**		Cable Seal 6 mm ²
35197158		Cable Seal 8 mm ²
35197159		Cable Seal 10 mm ²
35197160		Cable Seal 12 mm ²
35197162		Retainer - Cable Seal 6 & 8 mm ²
35197163		Retainer - Cable Seal 10 & 12 mm ²
35138799		OCS 1.5 Female Terminal sealed 0.75 - 1 mm ²
35138798		OCS 1.5 Female Terminal sealed 1.25 - 1.5 mm ²
35138799		Cable Seal OCS 1.5

* Non Aptiv terminal, please consult us
 ** Valid only for Header Connector 40A

DIMENSION MEASUREMENT SAMPLE

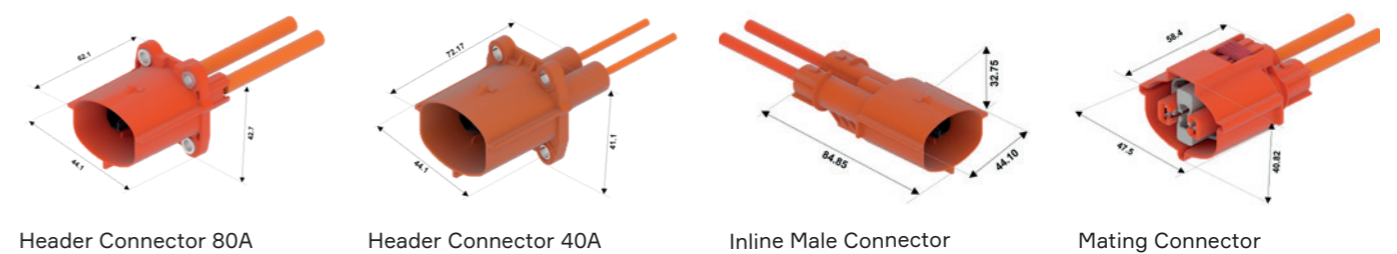

Part numbers, specifications, dimensions and performance data in this document are for general references only and are subject to change without notice. To verify product information, please contact an Aptiv representative.

Power Conversion

SELECTOR GUIDE

APPLICATIONS:

- HV battery
- E-motor for 3 W
- AC / DC inverter
- Power electric box
- Distribution Unit (HV PDU)
- DC / DC converter



Application	AC/DC inverter, DC/DC Converter, HV battery, Power electric box, HV PDU	E-motor, AC/DC inverter, DC/DC Converter, HV battery, Power electric box, HV PDU	AC/DC inverter, DC/DC Converter, HV battery, Power electric box, HV PDU						
Description	SHIELDPACK™ HV AK Class 4 SI 2 WAY	SHIELDPACK™ HV RCS890 SI	SHIELDPACK™ HV RCS800 SI DM	SHIELDPACK™ HV RCS890 SI DM	SHIELDPACK™ HV PP2000 SI	SHIELDPACK™ HV RCS800 SB	SHIELDPACK™ HV RCS890 SB RV 2 Way	POWERPACK HV RCS800 UI DM	
Amperage at 85°C	235 A	210 A	210 A	200 A	210 A	210 A	200 A	210 A	
Voltage	1000 V	1000 V	850 V	850 V	1000 V	1000 V	1000 V	850 V	
Orientation	90° 180°	90°	180°	90°	90°	180°	90°	180°	
# of ways (power)	2	2	2**	2	2	2	2	1	
HVIL	✓	✓	x**	✓	✓	✓	✓	x	
Shielding	Individual	Individual	Individual	Individual	Individual	Bundle	Bundle	Unshielded	
Vibration Class	V2	V4	V1*	V1*	V2	V1	V3	V1*	
Temperature Class	T4	T2	T3	T4	T3	T3	T1	T3	
Sections power	25 - 50 mm ²	16 - 70 mm ²	35 - 50 mm ²	35 - 50 mm ²	35 - 50 mm ²	35 - 50 mm ²	16 - 70 mm ²	35 - 50 mm ²	
Sections HVIL	0.5 mm ²	0.5 - 0.75 mm ²	-	0.35 - 1 mm ²	0.5 mm ²	0.5 - 0.75 mm ²	0.5 - 0.75 mm ²	-	
See Page	48 - 49	50 - 51	52 - 53	54 - 55	56 - 57	58 - 59	60 - 61	62 - 63	

E-motor, AC/DC inverter, DC/DC Converter, HV battery, Power electric box, HV PDU				AC/DC inverter, HV battery, Power electric box, HV PDU, E-motor				
SHIELDPACK™ HV RCS1100 SI	SHIELDPACK™ HV RCS1190 SI	SHIELDPACK™ HV AK Class 4 SI 3 WAY	SHIELDPACK™ HV RCS890 SB RV 3 WAY	SHIELDPACK™ HV AK PLASTIC PASS-THROUGH SI 16 - 50 mm ²	SHIELDPACK™ HV METAL PASS-THROUGH SI 25 - 50 mm ²	SHIELDPACK™ HV PLASTIC PASS-THROUGH SI 50 - 70 mm ²	SHIELDPACK™ HV METAL PASS-THROUGH SI 70 - 95 mm ²	SHIELDPACK™ HV PLASTIC PASS-THROUGH SI 95 - 120 mm ²
375 A	375 A	235 A	200 A	275 A	275 A	330 A	400 A	420 A
1000 V	1000 V	1000 V	1000 V	600 V (AC) 1000 V (DC)	600 V (AC) 1000 V (DC)	600 V (AC) 1000 V (DC)	600 V (AC) 1000 V (DC)	600 V (AC) 1000 V (DC)
180°	90°	90° 180°	90°	180°	180°	180°	180°	180°
2	2	3	3	1, 2 & 3	1	2	1	1, 2
✓	✓	✓	✓	x	x	x	x	x
Individual	Individual	Individual	Bundle	Individual	Individual	Individual	Individual	Individual
V2	V2	V2	V4	V3	V3	V4	V4	V3
T2	T3	T4	T2	T4	T3	T4	T3	T4
70 - 95 mm ²	70 - 95 mm ²	25 - 50 mm ²	16 - 70 mm ²	16 - 50 mm ²	25 - 50 mm ²	50 - 70 mm ²	70 - 95 mm ²	95 - 120 mm ²
0.5 - 0.75 mm ²	0.5 - 0.75 mm ²	0.5 mm ²	0.5 - 0.75 mm ²	-	-	-	-	-
64 - 65	66 - 67	68 - 69	70 - 71	72 - 73	74 - 75	76 - 77	78 - 79	80 - 81

* For classification V2 please consult an Aptiv representative.
 ** For solution with HVIL please contact your local Aptiv representative.

SHIELDPACK™

HV AK CLASS 4 SI 2 WAY AK



BENEFITS

- Standard AK interface
- High operating temperature
- High robustness against vibrations
- Optimized for better contact resistance and lesser retention force
- Offer both 90° and 180° systems, with same header connector and interface

FEATURES

- Up to 50 mm² cross sections
- Compliant to USCAR-2 / USCAR-37 (180°)
- Compliant to LV214 / LV215 and USCAR-2 / USCAR-37 (90°)
- Patented squeezing fixture for enhanced anti-vibration performance
- Lever on 180° can be placed on either side

AVAILABLE CONFIGURATIONS

Connector Type	Wire-to-device
Cable Exit Orientation	90°, 180°
Cable Range (mm ²)	25 - 50 (power) 0.5 (HVIL)
Terminal Type	8 mm round contact system
# of Power Terminals	2
Shielding	Individual
HVIL	Shunt on female
Assembly Assurance	CPA/TPA
Number of Indexes	4

APPLICATIONS

AC / DC inverter
HV battery
HV PDU
E-motor
Power electric box

PERFORMANCE

TEMP RANGE

+140°C

-40°C

MAX CURRENT AT 85°C

235 A

MAX DC VOLTAGE

1000 V

VIBRATION LEVEL

V2

SEALING CLASS

IP67
IP6K9K

ELECTRICAL PROTECTION

IP2XB

Index	Header connector	Mating connector 90°	Mating connector 180°	BOM
A	33351454	35128941	35168081 _A 35268206 _B	1
B	33351455	35165950	35201417 _A 35268207 _B	1

Lower case A and B on mating connector 180° indicates the side lever assist is available

ASSOCIATED PARTS

Part number		Description	BOM
Header connector			
13952636*		1.2 male terminal 0.5 - 0.75 mm ²	2
13954415*		1.2 male terminal 0.25 - 0.35 mm ²	2
Mating connector 90°			
25 mm ² Cable	35 mm ² Cable	50 mm ² Cable	
35172741	35172742 or 35150077		APT-890 female terminal
	35172744		Deep Drawn Socket Pin
	35142203		Outer Insulation Cap
35172724	35172725	35172726	Inner Ferrule
35172727	35172728	35172729	Outer Ferrule
35172732	35172733	35172734	Cable Seal
35149115	35142208	35149113	Cable Strain Relief
Mating connector 180°			
25 mm ² Cable	35 mm ² Cable	50 mm ² Cable	
35210072	35168235		APT-800 female terminal
	35168087		Shielding Can
	35201467		Lamella Insulation Socket
	35168234		Lock Retainer
35172724	35172725	35172726	Inner Ferrule
35168227	35168228	35168229	Inner Ferrule
35172732	35172733	35172734	Cable Seal
35149115	35142208	35149113	Cable Strain Relief

* Non Aptiv terminal, please consult us

DIMENSION MEASUREMENT SAMPLE

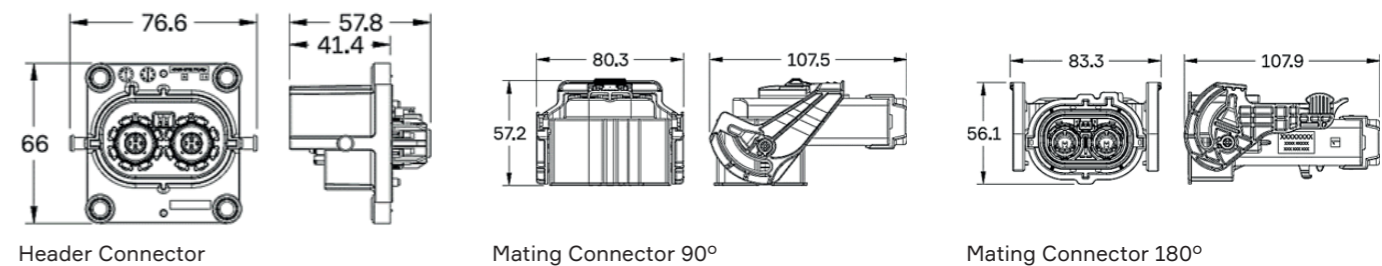

Part numbers, specifications, dimensions and performance data in this document are for general references only and are subject to change without notice. To verify product information, please contact an Aptiv representative.

SHIELDPACK™

HV RCS890 SI 2 WAY

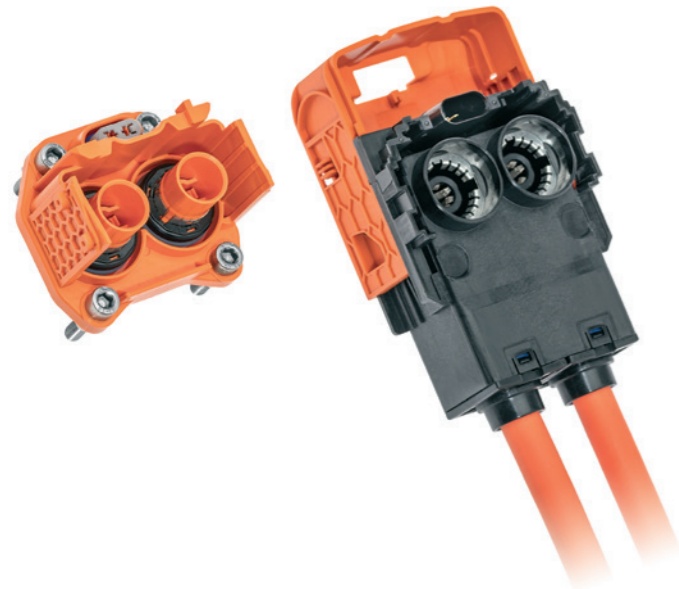

BENEFITS

- Specifically designed for compact environments
- High-water protections resulting from sealed unmated header
- Easy assembly thanks to slider feature on female connector

FEATURES

- Header has flat and simple device interface
- Connectors dismounting in 2 steps for time delay between interlock opening and power disconnection
- Slider solution offers the maximum pressure surface in limited space conditions

APPLICATIONS

- AC / DC inverter
- DC / DC converter
- HV battery
- Power electric box
- HV PDU

AVAILABLE CONFIGURATIONS

Connector Type	Wire-to-device
Cable Exit Orientation	90°
Cable Range (mm²)	35 - 70
Terminal Type	8 mm round contact system
# of Power Terminals	2
Shielding	Individual
HVIL	Shunt on female
Assembly Assurance	CPA
Number of Indexes	1

PERFORMANCE

TEMP RANGE

+125°C

-40°C

MAX CURRENT AT 85°C

210 A

ELECTRICAL PROTECTION

IP2XB

MAX DC VOLTAGE

600 V

VIBRATION LEVEL

V1*

* For classification V2 please consult an Aptiv representative.

SEALING CLASS

IP67
IP6K9K

Header connector	Mating connector	BOM
35254402	35254366	1

ASSOCIATED PARTS

Part number	Description	BOM
Header		
15549847	DSQ 1.5 female terminal silver-plated 0.35 - 0.5 mm²	2
15549848	DSQ 1.5 female terminal silver-plated 0.75 - 1 mm²	
15441379	DCS/DSQ 1.5 male red single wire seal 0.22 - 0.5 mm²	2
15441380	DCS/DSQ 1.5 male grey single wire seal 0.75 - 1 mm²	
Mating Connector		
33502217	RCS 890 female terminal silver-plated 35 - 50 mm²	2
35225104	RCS 890 female terminal silver-plated 70 mm²	
35082415	Outer ferrule 35 mm²	2
35234890	Outer ferrule 50 - 70 mm²	
35084603	Recovery shield assembly 35 mm²	2
35236787	Recovery shield assembly 50 - 70 mm²	
35084610	Single wire seal & retainer 35 mm²	2
35084586	Single wire seal & retainer 50 mm²	
35236755	Single wire seal & retainer 70 mm²	

DIMENSION MEASUREMENT SAMPLE

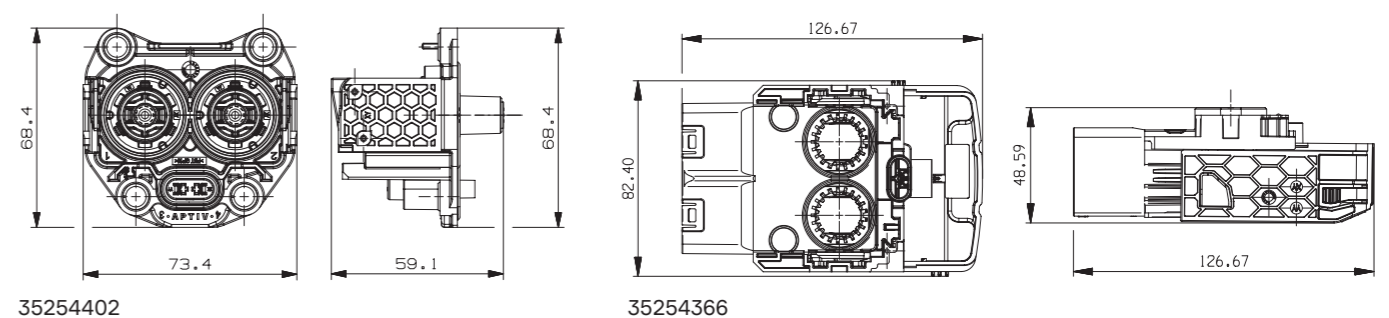

Part numbers, specifications, dimensions and performance data in this document are for general references only and are subject to change without notice. To verify product information, please contact an Aptiv representative.

SHIELDPACK™

HV RCS800 SI DM 2 WAY

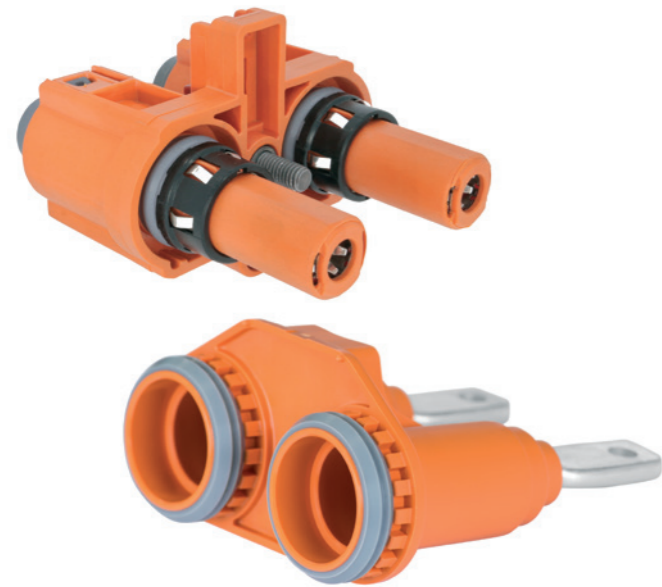

BENEFITS

- Cost effective solution with unshielded terminal holder within device replacing traditional shielded headers
- Unique and safe mating screwing with innovative Screw Position Assurance (SPA)
- Header is sealed in both mated and unmated position

FEATURES

- Robust bolt driven mate assist
- Fingersafe via plastic tips on male pins
- Cable range: ~ 50 mm² and smaller

APPLICATIONS

- AC / DC inverter
- DC / DC converter
- HV battery
- Power electric box
- HV PDU

AVAILABLE CONFIGURATIONS

Connector Type	Wire-to-device
Cable Exit Orientation	180°
Cable Range (mm ²)	35 - 50 (power) 0.35 - 1.0 (HVIL)
Terminal Type	8 mm round contact system
# of Power Terminals	2
Shielding	Individual
HVIL	Shunt on female
Assembly Assurance	SPA
Number of Indexes	1

PERFORMANCE

TEMP RANGE

+125°C

-40°C

MAX CURRENT AT 85°C

210 A

ELECTRICAL PROTECTION

IP2XB

MAX DC VOLTAGE

850 V

VIBRATION LEVEL

V1*

* For classification V2 please consult an Aptiv representative.

SEALING CLASS

IP67
IP6K9K

Header*	Header with HVIL**	Mating connector	BOM
35099885	35099880	35098453	1

* Header connector is a fully assembled part and therefore has no associated parts.
 ** Please contact your local Aptiv representative for serial production information.

ASSOCIATED PARTS

Part number	Description	BOM
Mating connector		
13893887	RCS 800 female terminal silver-plated 35 - 50 mm ²	2
35082410	Inner ferrule 35 and 50 mm ²	2
35082415	Outer ferrule 35 and 50 mm ²	2
35099247	Single wire seal & retainer 35 mm ²	2
35099248***	Single wire seal & retainer 50 mm ²	
35092416	RCS800 tube 35 - 50 mm ²	2

*** Available only by prototype, please contact your local Aptiv representative for more information on serial production.

DIMENSION MEASUREMENT SAMPLE

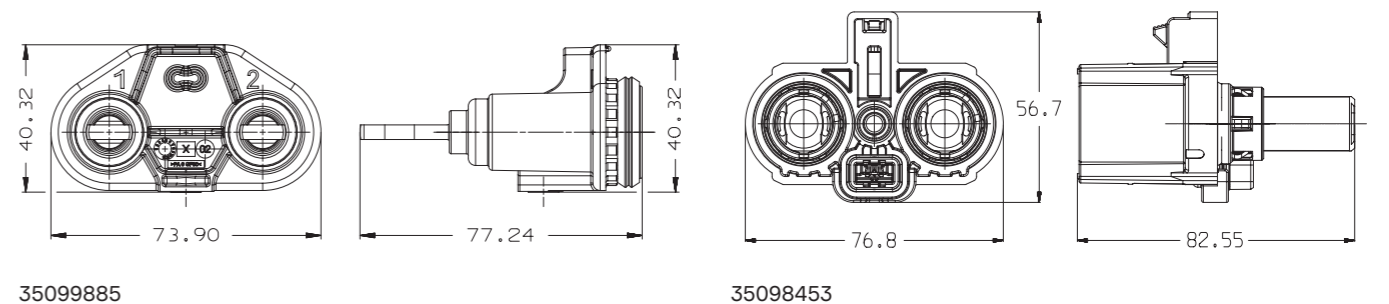

SHIELDPACK™

HV RCS890 SI DM 2 WAY



BENEFITS

- Cost effective solution with unshielded terminal holder within device replacing traditional shielded headers
- Unique and safe mating screwing with innovative Screw Position Assurance (SPA)
- Header is sealed in both mated and unmated position

FEATURES

- Robust bolt driven mate assist
- Fingersafe via plastic tips on male pins
- Cable range: ~ 50 mm² and smaller

APPLICATIONS

- AC / DC inverter
- DC / DC converter
- HV battery
- Power electric box
- HV PDU

AVAILABLE CONFIGURATIONS

Connector Type	Wire-to-device
Cable Exit Orientation	90°
Cable Range (mm ²)	35 - 50 (power) 0.35 - 1 (HVIL)
Terminal Type	8 mm round contact system
# of Power Terminals	2
Shielding	Individual
HVIL	Shunt on female
Assembly Assurance	SPA (Screwed Position Assurance)
Number of Indexes	1

PERFORMANCE

TEMP RANGE

+125°C

-40°C

MAX CURRENT AT 85°C

200 A

MAX DC VOLTAGE

850 V

VIBRATION LEVEL

V1*

* For classification V2 please consult an Aptiv representative.

SEALING CLASS

IP67
IP6K9K

ELECTRICAL PROTECTION

IP2XB

Header	Mating connector	BOM
35084594	35084575	1

ASSOCIATED PARTS

Part number	Description	BOM
Header		
15549847	DSQ 1.5 female terminal silver-plated 0.35 - 0.5 mm ²	2
15549848	DSQ 1.5 female terminal silver-plated 0.75 - 1 mm ²	
15441379	DCS/DSQ 1.5 red single wire seal 0.22 - 0.5 mm ²	2
15441380	DCS/DSQ 1.5 grey single wire seal 0.75 - 1 mm ²	
Mating connector		
33502217	RCS 890 female terminal silver-plated 35 - 50 mm ²	2
35082415	Outer ferrule 35 mm ²	2
35234890	Outer ferrule 50 mm ²	
35084603	Recovery shield assembly 35 mm ²	2
35236787	Recovery shield assembly 50 mm ²	
35084610	Single wire seal & retainer 35 mm ²	2
35084586	Single wire seal & retainer 50 mm ²	

DIMENSION MEASUREMENT SAMPLE

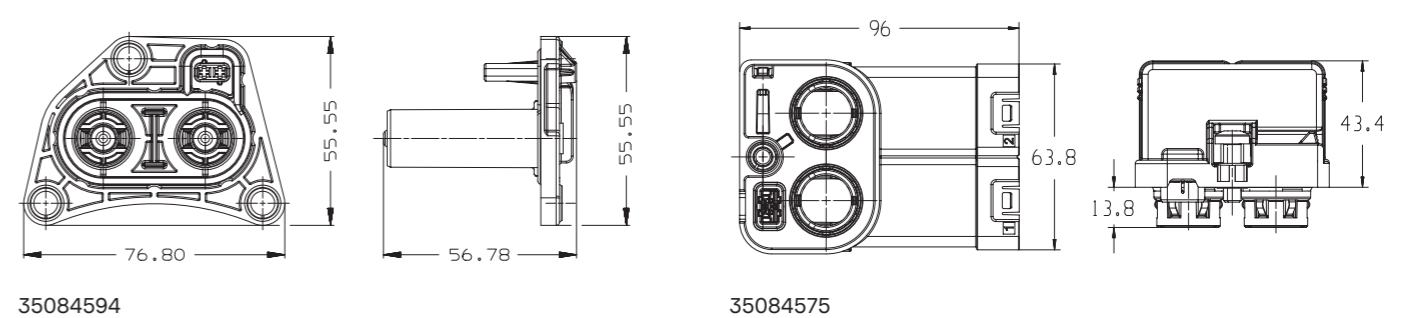

SHIELDPACK™

HV PP2000 SI 2 WAY

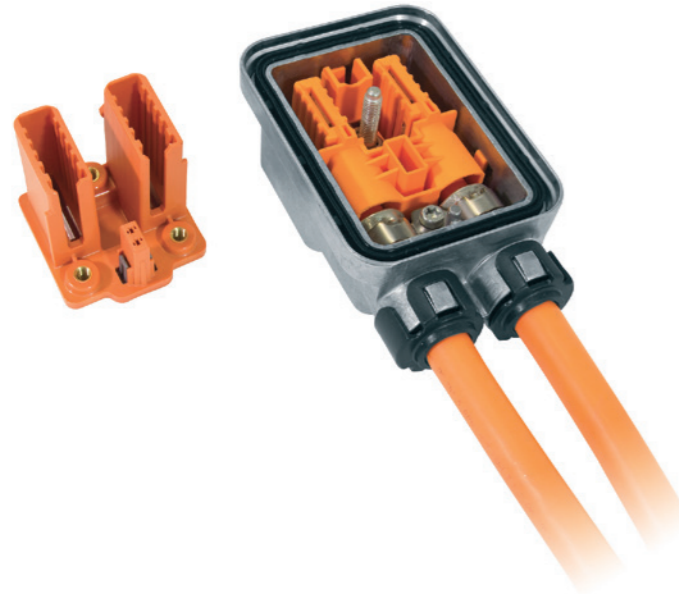

BENEFITS

- Header interface is integrated into device case
- Cost-effective full plastic header assembled from inside out
- Bolt driven mate assist
- Ultrasonic welding used for power terminal

FEATURES

- Internal HVIL shunted in harness connector
- Finger proof and non-finger proof options available
- Provides finger proof terminal towers and HVIL
- Header accepts busbars provided by module

APPLICATIONS

- AC / DC inverter
- DC / DC converter
- HV battery
- Power electric box
- HV PDU

AVAILABLE CONFIGURATIONS

Connector Type	Wire-to-device
Cable Exit Orientation	90°
Cable Range (mm²)	35 - 50 (power) 0.5 (HVIL)
Terminal Type	Power Pack 2000 17.7
# of Terminals	2
Shielding Type	Individual
HVIL	Shunt on female
Assembly Assurance	CPA/TPA
Number of Indexes	1

PERFORMANCE

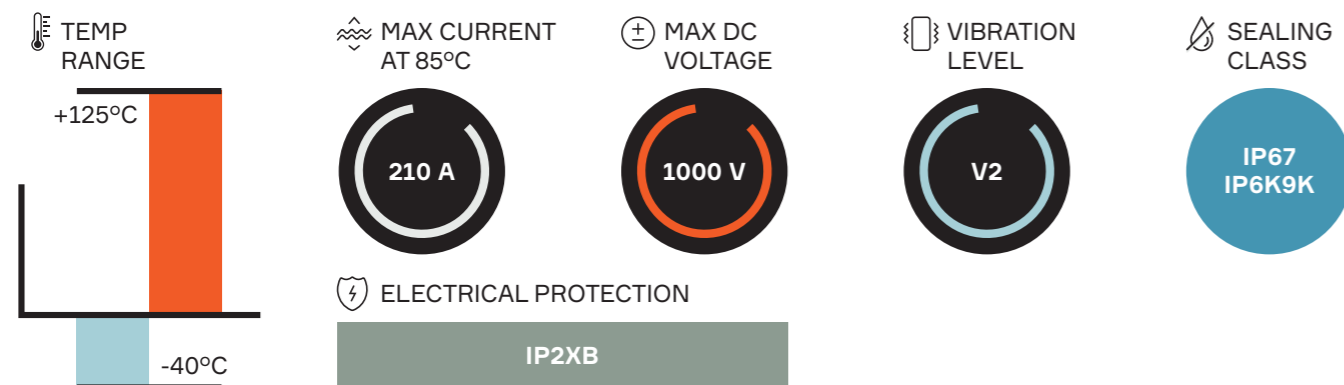

Header connector	Mating connector	BOM
33346375	33352038	1

ASSOCIATED PARTS

Part number	Description	BOM
Header		
15432237	CTS female terminal silver-plated HVIL 0.35 mm²	2
33346376	HVIL TPA	1
Mating Connector		
13801592	Power Pack 2000 female sonic weld terminal	2
33352058	Inner ferrule 35 mm²	2
33352059	Inner ferrule 50 mm²	2
33352056	Outer ferrule 35 mm² & 50 mm²	2
33352048	Cable seal 35 mm²	2
33352049	Cable seal 50 mm²	2
33352051	Strain relief 35 mm²	2
33352052	Strain relief 50 mm²	2
33352055	TPA	1
13849267	Fastener M5	1

DIMENSION MEASUREMENT SAMPLE

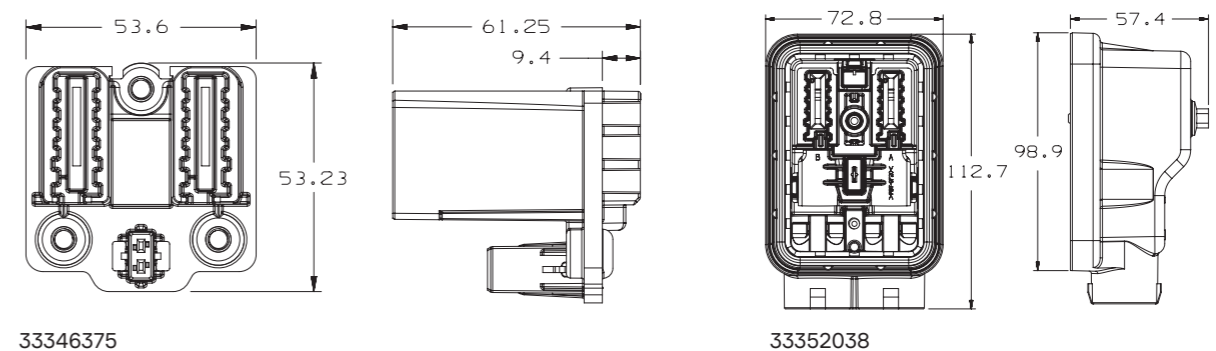

Part numbers, specifications, dimensions and performance data in this document are for general references only and are subject to change without notice. To verify product information, please contact an Aptiv representative.

SHIELDPACK™

HV RCS800 SB 2 WAY

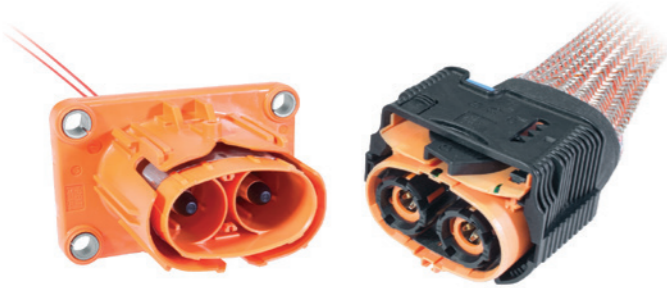

BENEFITS

- Easy to assemble with integrated ErgoMate™ Axial Mating Assist System on harness connector
- Compact package with unique integrated electric interlock
- Header is sealed in both mated and unmated positions

FEATURES

- Bundle shielding with external braid
- Panel mount to device with face seal to module
- Two-stage disconnect for safe unmating

APPLICATIONS

- AC / DC inverter
- DC / DC converter
- HV battery
- Power electric box
- HV PDU

AVAILABLE CONFIGURATIONS

Connector Type	Wire-to-device
Cable Exit Orientation	180°
Cable Range (mm²)	35 - 50 (power) 0.5 - 0.75 (HVIL)
Terminal Type	8 mm round contact system
# of Power Terminals	2
Shielding	Bundle
HVIL	Shunt on female
Assembly Assurance	CPA
Number of Indexes	2

PERFORMANCE

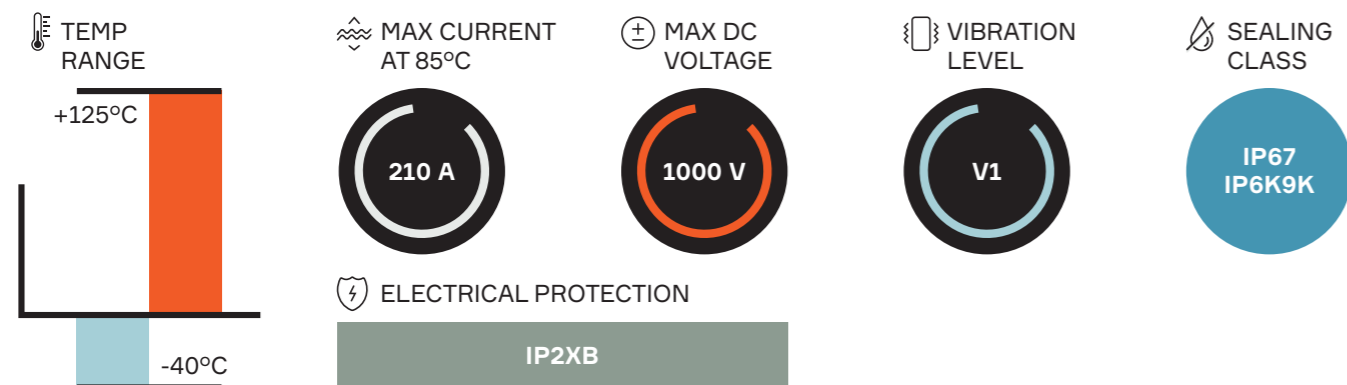

Index	Header connector	Mating connector	BOM
1	33511764	13974469	1
2	33511762	33511761	

ASSOCIATED PARTS

Part number	Description	BOM
Header		
33512193	RCS 800/890 male pin terminal silver version standard length	2
33511746	RCS 800/890 male pin terminal silver version V1 length	
33511747	RCS 800/890 male pin terminal silver version V2 length	
10779703	DCS2 1.5 male terminal gold-plated 0.5 - 1 mm²	2
15441379	DCS/DSQ 1.5 red single wire seal 0.22 - 0.5 mm²	2
15441380	DCS/DSQ 1.5 grey single wire seal 0.75 - 1 mm²	
Mating Connector		
13893887	RCS 800 female terminal silver version 35 - 50 mm²	2
13893889	RCS 800 female retainer (plug)	2
13893888	RCS 800 female 35 - 40 mm² (plug)	2
13923559	RCS 800 female 50 mm² (plug)	

DIMENSION MEASUREMENT SAMPLE

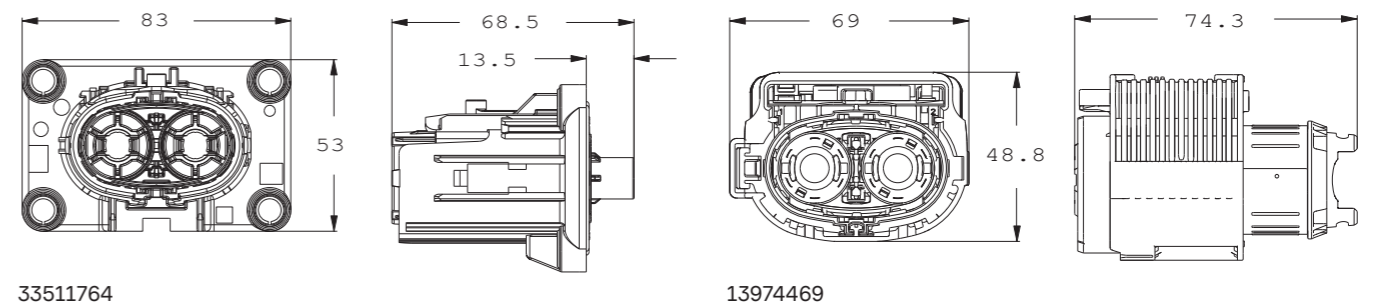

Part numbers, specifications, dimensions and performance data in this document are for general references only and are subject to change without notice. To verify product information, please contact an Aptiv representative.

SHIELDPACK™

HV RCS890 SB RV 2 WAY

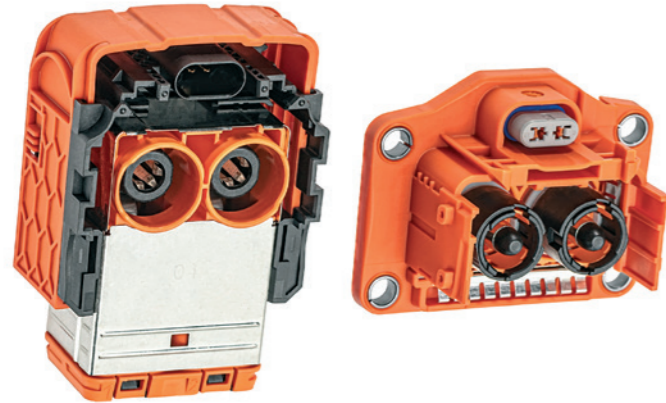

BENEFITS

- Ultra compact design for applications with space constraints
- Panel mount to device with face seal to module
- Header is sealed in both mated and unmated position

FEATURES

- Two-stage disconnect for safe unmating
- Easier mating with Slider Mating Assist System on harness connector
- Bundle shielding with external braid
- HVIL shunted in harness connector

APPLICATIONS

- AC / DC inverter
- DC / DC converter
- HV battery
- Power electric box
- HV PDU

AVAILABLE CONFIGURATIONS

Connector Type	Wire-to-device
Cable Exit Orientation	90°
Cable Range (mm²)	16 - 70 (power) 0.35 - 1 (HVIL)
Terminal Type	8 mm round contact system
# of Power Terminals	2
Shielding	Bundle
HVIL	Shunt on female
Assembly Assurance	CPA
Number of Indexes	2

PERFORMANCE

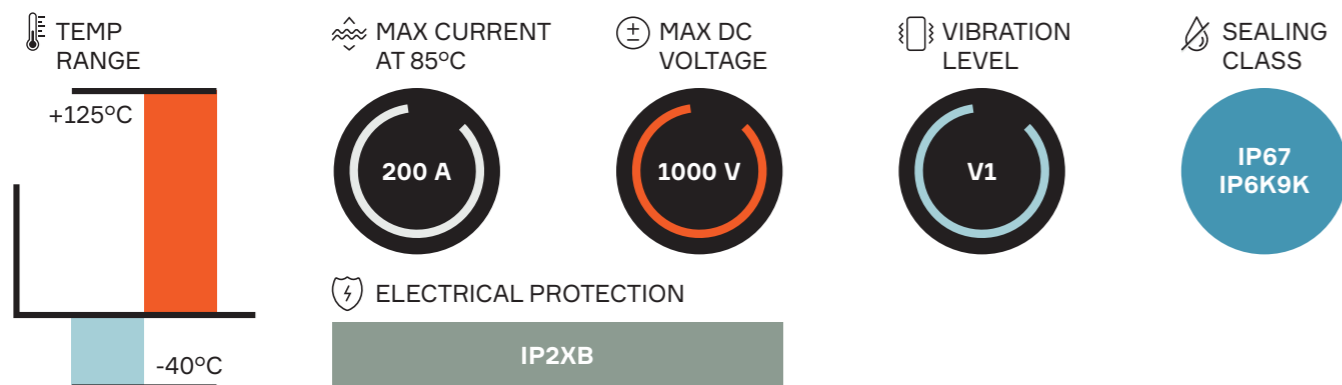

Index	Header connector	Mating connector	BOM
1	35326611	35092244	1
2	35326613	35092239	

ASSOCIATED PARTS

Part number	Description	BOM
Header		
10811962	DCS2 1.5 female terminal gold-plated 0.5 - 1 mm²	2
15441379	DCS/DSQ 1.5 red single wire seal 0.35 - 0.5 mm²	2
15441380	DCS/DSQ 1.5 grey single wire seal 0.75 - 1 mm²	2
35304635	RCS 800 male bus bar terminal silver version polarized pin	2
Mating Connector		
33308229	RCS 890 female terminal silver version 16 - 25 mm²	2
33502217	RCS 890 female terminal silver version 35 - 50 mm²	
35225104	RCS 890 female terminal silver version 70 mm²	2
33269218	RCS 890 single wire seal & retainer (plug) 16 - 25 mm²	
33511753	RCS 890 2-way female single wire seal & retainer (plug) 35 - 40 mm²	
33511754	RCS 890 2-way female single wire seal & retainer (plug) 50 mm²	2
35199856	RCS 890 2-way female single wire seal & retainer (plug) 70 mm²	
35091447	RCS 890 2-way half clamp	2

DIMENSION MEASUREMENT SAMPLE

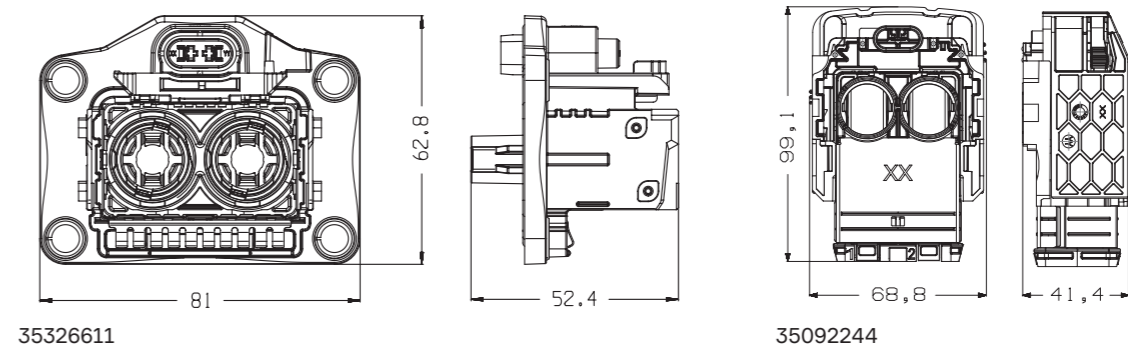

35326611

35092244

POWERPACK

HV RCS800 UI DM 1 WAY



BENEFITS

- Cost effective thanks to the direct connection between the female connector and the male terminals within the device case
- Unique and safe mating screwing with innovative Screw Position Assurance (SPA)
- Versatile solution covering multiple applications: high voltage power conversion and 48 volt

FEATURES

- Robust bolt driven mate assist
- Fingersafe via plastic tips on male pins
- Unshielded connector system

APPLICATIONS

- AC / DC inverter
- DC / DC converter
- HV battery
- Power electric box
- HV PDU

AVAILABLE CONFIGURATIONS

Connector Type	Wire-to-device
Cable Exit Orientation	180°
Cable Range (mm ²)	35 - 50 (power)
Terminal Type	8 mm round contact system
# of Power Terminals	1
Shielding	None
HVIL	None
Assembly Assurance	SPA
Number of Indexes	1

PERFORMANCE

TEMP RANGE

+125°C

-40°C

MAX CURRENT AT 85°C

210 A

MAX DC VOLTAGE

850 V

VIBRATION LEVEL

V1*

* For classification V2 please consult an Aptiv representative.

SEALING CLASS

IP67
IP6K9K

ELECTRICAL PROTECTION

IP2XB

Header connector*	Mating connector	BOM
35098440	35098437	1

* Header connector is a fully assembled part and therefore has no associated parts.

ASSOCIATED PARTS

Part number	Description	BOM
Mating Connector		
13893887	RCS 800 female terminal 35 - 50 mm ²	1
13893888	Female black single wire seal 35 mm ²	1
13923559	Female grey single wire seal 50 mm ²	
13893889	Retainer	1

DIMENSION MEASUREMENT SAMPLE

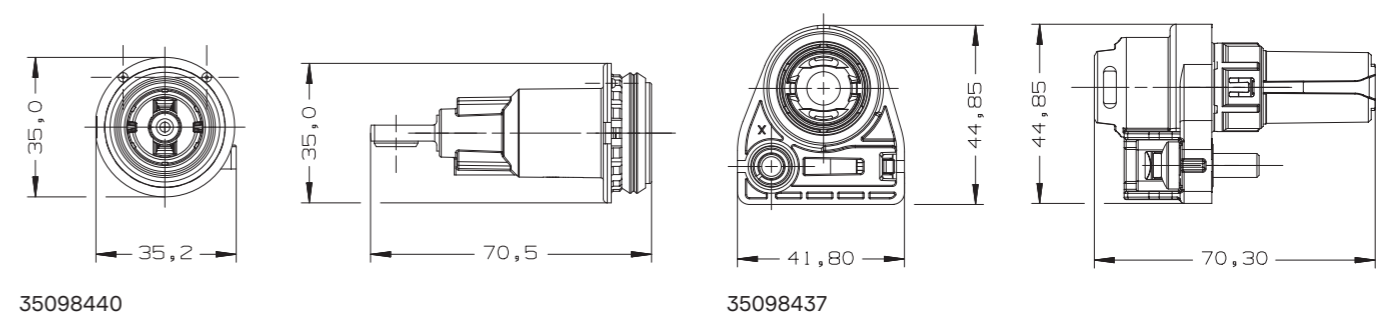

Part numbers, specifications, dimensions and performance data in this document are for general references only and are subject to change without notice. To verify product information, please contact an Aptiv representative.

SHIELDPACK™

HV RCS1100 SI 2 WAY



BENEFITS

- Specifically designed for harsh environment applications
- 90° header option also available (see HV RCS 1190 Series datasheet)
- Robust lever ensuring easy mating/unmating with low forces
- Same device interface for both RCS 1100 and RCS 1190

FEATURES

- Up to 95 mm² cross sections
- Made for applications with needs up to 375A
- Compliant to LV214/215 module

APPLICATIONS

- Inverter
- E-Motor
- HV PDU
- HV-Battery

AVAILABLE CONFIGURATIONS

Connector Type	Wire-to-device
Cable Exit Orientation	180°
Cable Range (mm ²)	50 - 95 (power) 0.5 - 0.75 (HVIL)
Terminal Type	11 mm round contact system
# of Power Terminals	2
Shielding	Individual
HVIL	Shunt on female
Assembly Assurance	CPA
Number of Indexes	2

PERFORMANCE

TEMP RANGE

+140°C

-40°C

MAX CURRENT AT 85°C

375 A

MAX DC VOLTAGE

1000 V

VIBRATION LEVEL

V2

SEALING CLASS

IP67
IP6K9K

ELECTRICAL PROTECTION

IP2XB

Index	Header connector	Mating connector	BOM
1	35339374	35339246	1
2	35339375	35339248	

ASSOCIATED PARTS

Part number	Description	BOM
Header		
15414399	HVIL DSQ terminal gold-plated 0.35 - 0.5 mm ²	2
15414401	HVIL DSQ terminal gold-plated 0.75 - 1 mm ²	
Mating Connector		
35347214	RCS 1100 female terminal silver version 50 mm ²	2
35339282	RCS 1100 female terminal silver version 70 mm ²	
35339287	RCS 1100 female terminal silver version 95 mm ²	
35210585	Inner ferrule 50 mm ²	2
35210586	Inner ferrule 70 mm ²	
35210587	Inner ferrule 95 mm ²	
35347217	Outer ferrule 50 mm ²	2
35339328	Outer ferrule 70 mm ²	
35339329	Outer ferrule 95 mm ²	
35347219	Cable strain relief 50 mm ²	2
35339348	Cable strain relief 70 mm ²	
35339349	Cable strain relief 95 mm ²	
35347218	Cable seal 50 mm ²	2
35339332	Cable seal 70 mm ²	
35339333	Cable seal 95 mm ²	

DIMENSION MEASUREMENT SAMPLE

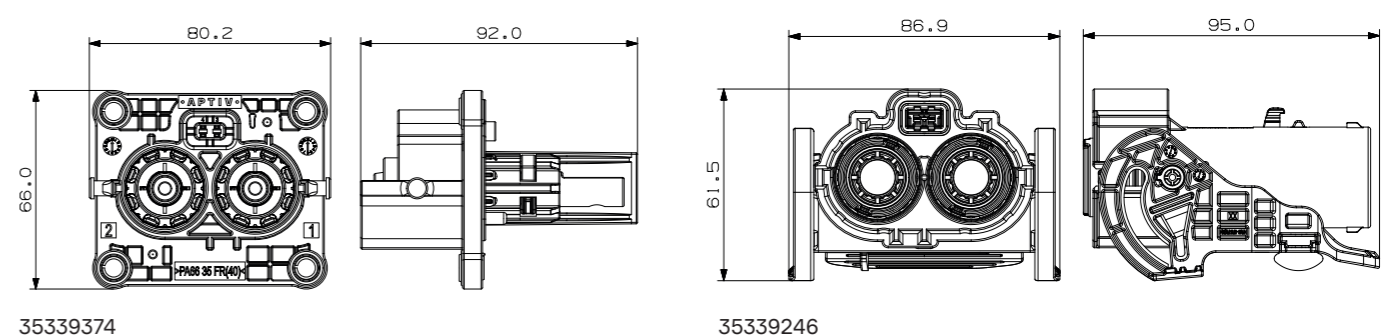

Part numbers, specifications, dimensions and performance data in this document are for general references only and are subject to change without notice. To verify product information, please contact an Aptiv representative.

SHIELDPACK™

HV RCS1190 SI 2 WAY

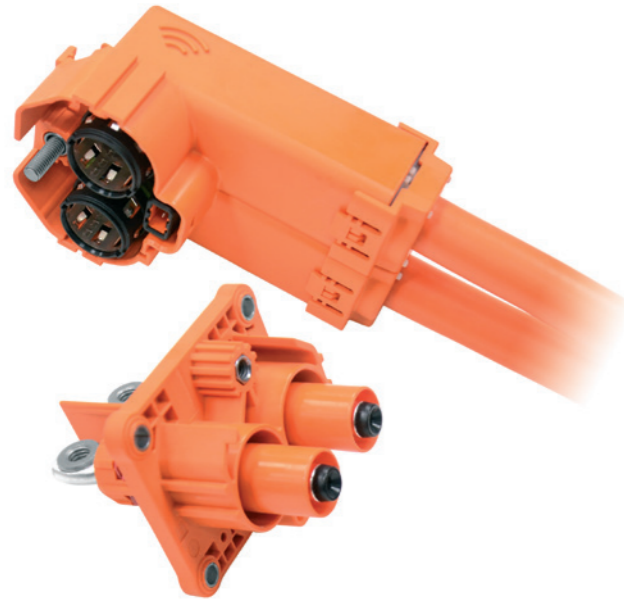

BENEFITS

- Specifically designed for harsh environment applications
- 180° header option also available (see HV RCS 1100 Series datasheet)
- Unique and safe mating screwing thanks to innovative Screw Position Assurance
- Same device interface for both RCS 1100 and RCS 1190

FEATURES

- Up to 95 mm² cross sections
- Made for applications with needs up to 375A
- Compliant to LV214/215

AVAILABLE CONFIGURATIONS

Connector Type	Wire-to-device
Cable Exit Orientation	90°
Cable Range (mm ²)	50 - 95 (power) 0.5 - 0.75 (HVIL)
Terminal Type	11 mm round contact system
# of Power Terminals	2
Shielding	Individual
HVIL	Shunt on female
Assembly Assurance	SPA (Screw Position Assurance)
Number of Indexes	2

APPLICATIONS

Inverter
E-Motor
HV PDU
HV-Battery

PERFORMANCE

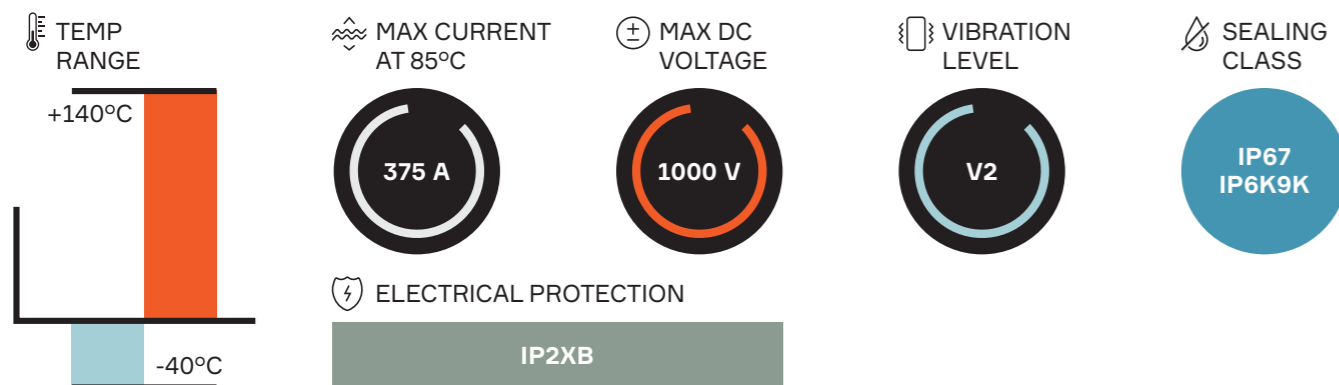

Index	Header connector	Mating connector	BOM
1	35210644	35210554	1
2	35210645	35210555	

ASSOCIATED PARTS

Part number	Description	BOM
Header Connector		
15414399	HVIL DSQ terminal gold-plated 0.35 - 0.5 mm ²	2
15414401	HVIL DSQ terminal gold-plated 0.75 - 1 mm ²	
Mating Connector		
35210576	RCS 1190 female terminal silver version 50 mm ²	2
35210578	RCS 1190 female terminal silver version 70/95 mm ²	
35210585	Inner ferrule 50 mm ²	2
35210586	Inner ferrule 70 mm ²	
35210587	Inner ferrule 95 mm ²	
35210591	Outer ferrule 50 mm ²	2
35210592	Outer ferrule 70 mm ²	
35210593	Outer ferrule 95 mm ²	
35210637	Cable strain relief 50 mm ²	2
35210638	Cable strain relief 70 mm ²	
35210639	Cable strain relief 95 mm ²	
35210634	Cable seal 50 mm ²	2
35210635	Cable seal 70 mm ²	
35210636	Cable seal 95 mm ²	

DIMENSION MEASUREMENT SAMPLE

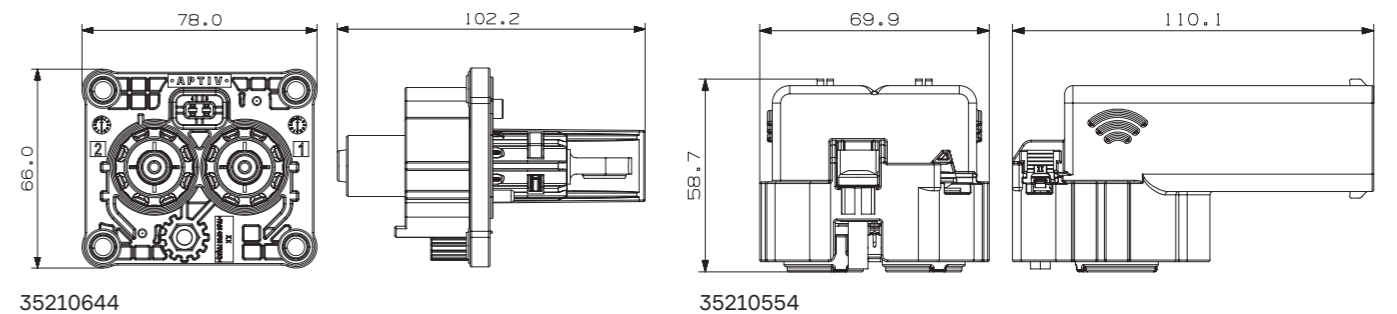

Part numbers, specifications, dimensions and performance data in this document are for general references only and are subject to change without notice. To verify product information, please contact an Aptiv representative.

SHIELDPACK™

HV AK CLASS 4 SI 3 WAY



BENEFITS

- High operating temperature
- High robustness against vibrations
- Optimized for better contact resistance and lesser retention force

FEATURES

- Up to 50 mm² cross sections
- For applications with needs up to 235A
- Compliant to LV214 / LV215
- Patented squeezing fixture for enhanced anti-vibration performance

APPLICATIONS

- Powertrain High Voltage / Current Modules:
- Power Converter / Inverter
- E-motor
- HV Battery
- HV Power Distribution Unit (PDU)

AVAILABLE CONFIGURATIONS

Connector Type	Wire-to-device
Cable Exit Orientation	90°
Cable Range (mm ²)	25 / 35 / 50
Terminal Type	8 mm round contact
# of Cavities	3
Shielding	Individual
HVIL	Shunt
Assembly Assurance	CPA
# of Code Indexes	2

PERFORMANCE

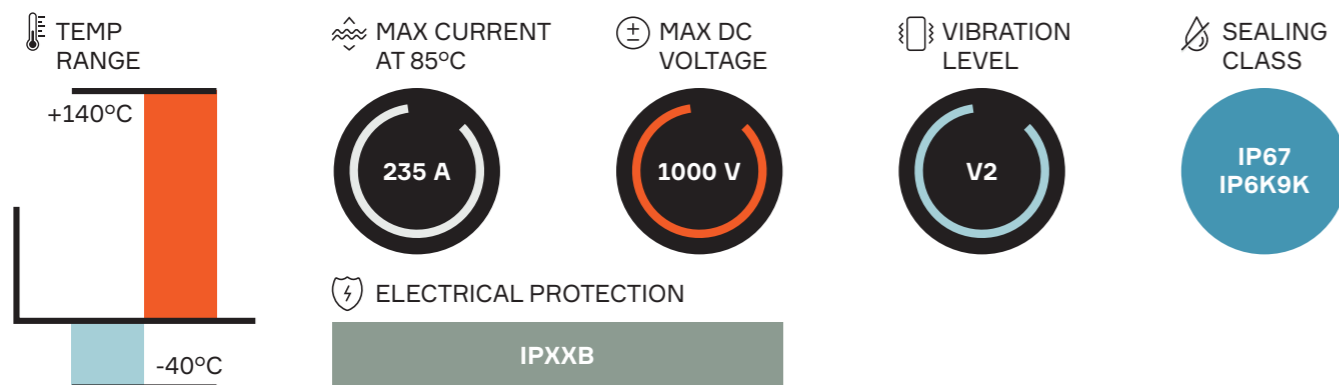

Index	Header Connector	Mating Connector	BOM
A	35249282	35255867	1
B	35253672	35263285	

ASSOCIATED PARTS

Part number		Description	BOM
Header Connector			
35244766		APT 6.3 Male Terminal 4 - 6 mm ²	2
13952636		1.2 Male Terminal 0.5 - 0.75 mm ²	2
Mating connector			
25 mm ² Cable	35 mm ² Cable	50 mm ² Cable	
35172741	35172742 or 35150077		APT-890 Female Terminal 3
	35172744		Deep Drawn Socket Pin 3
	35142203		Outer Insulation Cap 3
35172724	35172725	35172726	Inner Ferrule 3
35172727	35172728	35172729	Outer Ferrule 3
35172732	35172733	35172734	Cable Seal 3
35149115	35142208	35149113	Cable Strain Relief 3

DIMENSION MEASUREMENT SAMPLE

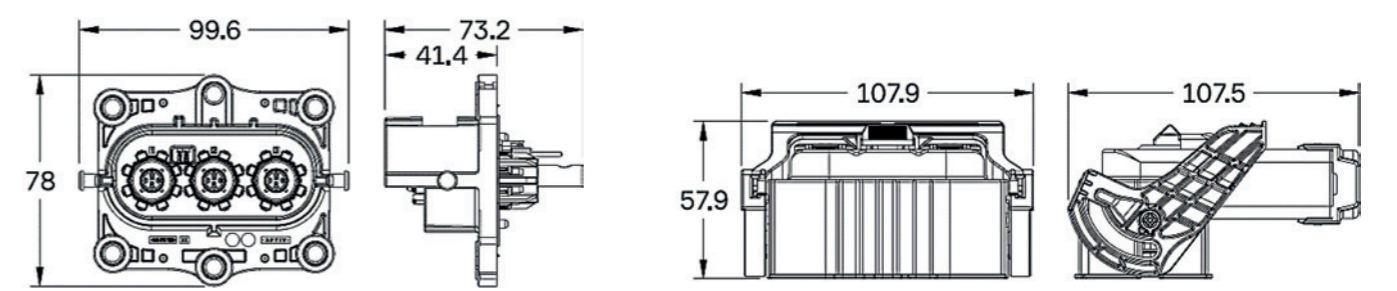

Header Connector

Mating Connector

Part numbers, specifications, dimensions and performance data in this document are for general references only and are subject to change without notice. To verify product information, please contact an Aptiv representative.

SHIELDPACK™

HV RCS890 SB RV 3 WAY

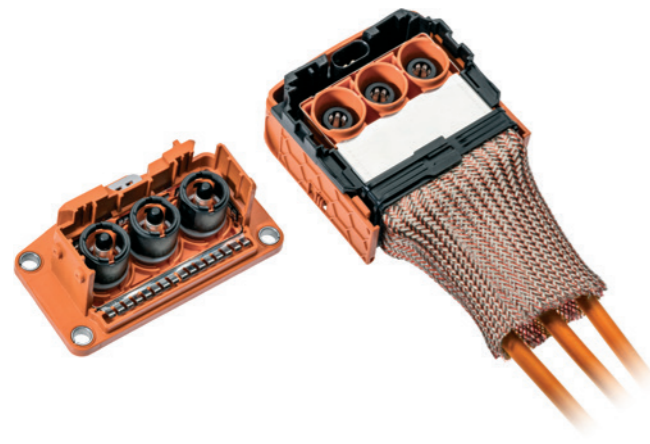

BENEFITS

- Ultra compact design for applications with space constraints
- Panel mount to device with face seal to module
- Header is sealed in both mated and unmated position

FEATURES

- Two-stage disconnect for safe unmating
- Easier mating with Slider Mating Assist System on harness connector
- Bundle shielding with external braid
- HVIL shunted in harness connector

APPLICATIONS

- AC / DC inverter
- DC / DC converter
- HV battery
- Power electric box
- HV PDU

AVAILABLE CONFIGURATIONS

Connector Type	Wire-to-device
Cable Exit Orientation	90°
Cable Range (mm²)	16 - 70 (power) 0.5 - 0.75 (HVIL)
Terminal Type	8 mm round contact system
# of Power Terminals	3
Shielding	Bundle
HVIL	Shunt on female
Assembly Assurance	CPA
Number of Indexes	2

PERFORMANCE

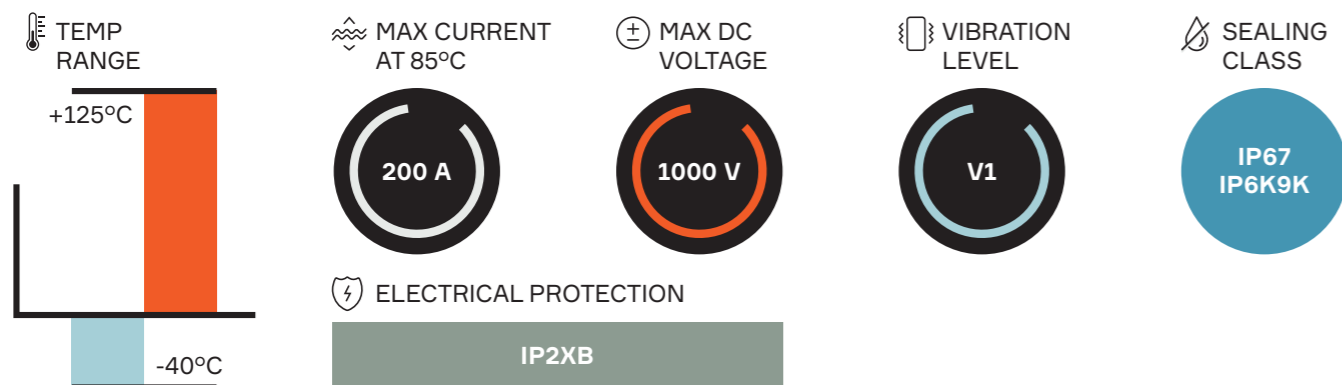

Index	Header connector	Mating connector	BOM
1	35310180	33272670	1
2	35310181	33282936	

ASSOCIATED PARTS

Part number	Description	BOM
Header		
35304635	RCS 800 male bus bar terminal silver version polarized pin	3
10811962	DCS2 1.5 female terminal gold-plated 0.5 - 1 mm²	2
15441379	DCS/DSQ 1.5 red single wire seal 0.35 - 0.5 mm²	2
15441380	DCS/DSQ 1.5 grey single wire seal 0.75 - 1 mm²	
Mating Connector		
33308229	RCS 890 female terminal silver version 16 - 25 mm²	3
33502217	RCS 890 female terminal silver version 35 - 50 mm²	
35225104	RCS 890 female terminal silver version 70 mm²	
33269218	RCS 890 single wire seal & retainer 16 - 25 mm²	3
33511753	RCS 890 single wire seal & retainer 35 - 40 mm²	
33511754	RCS 890 single wire seal & retainer 50 mm²	
35199856	RCS 890 single wire seal & retainer 70 mm²	2
33272561	RCS 890 3-way half clamp	

DIMENSION MEASUREMENT SAMPLE

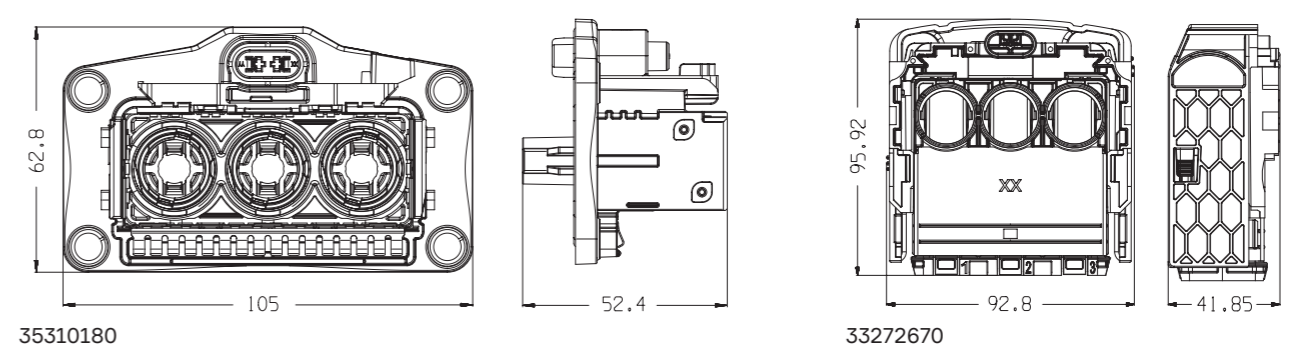

Part numbers, specifications, dimensions and performance data in this document are for general references only and are subject to change without notice. To verify product information, please contact an Aptiv representative.

SHIELDPACK™

HV AK PLASTIC PASS-THROUGH SI

16-50mm² 1, 2 AND 3 WAY **AK**



BENEFITS

- Very compact dimensions
- High robustness against vibrations
- Higher operating temperatures

FEATURES

- Ring terminal is bolted to device
- Cables are 360° individually shielded
- High voltage panel mount system
- Fully interchangeable with other AK supplier sources

APPLICATIONS

- AC / DC inverter
- HV battery
- HV PDU
- Power electric box
- E-motor

AVAILABLE CONFIGURATIONS

Connector Type	Pass-through
Cable Exit Orientation	180°
Cable Range (mm ²)	16 - 50 (power)
Terminal Type	O-ring
Shielding	Individual
HVIL	None

PERFORMANCE

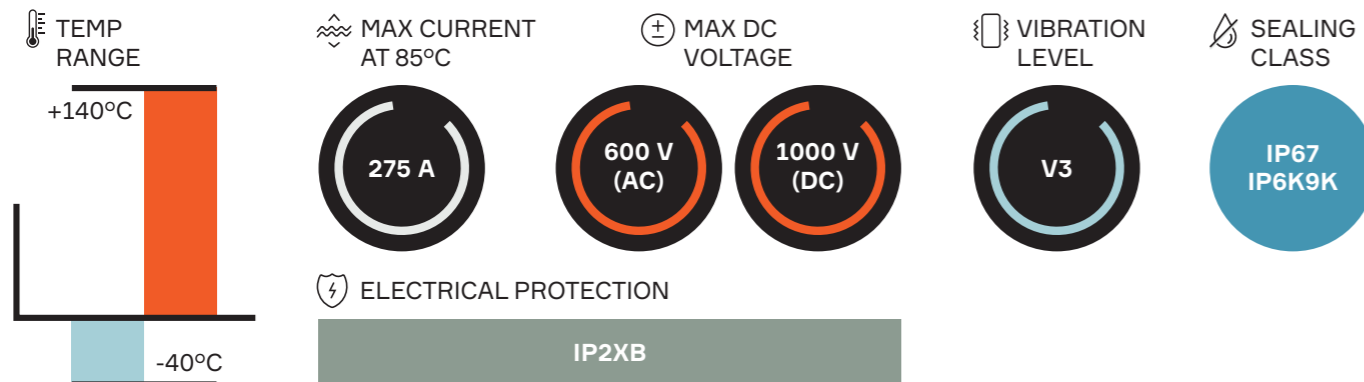

Main Housing Body Components

Code	Number of ways			BOM
	1	2	3	
A	33340524	33340525	33340526	1

ASSOCIATED PARTS

Description	Cable size				BOM*
	16 mm ²	25 mm ²	35 mm ²	50 mm ²	
Peripheral seal	35116341				1, 2 or 3
Inner ferrule	35172747				1, 2 or 3
Outer ferrule	33340554	35172745	35172743	33340551	1, 2 or 3
Single wire seal	33340537	35172739	35172738	33340534	1, 2 or 3
Cable strain relief	33340542	33340541	33340540	33340539	1, 2 or 3

* Depending on if the component is for 1, 2 or 3 Way pass-through.

Component Kits**

Code	Cable size				BOM
	16 mm ²	25 mm ²	35 mm ²	50 mm ²	
1 Way					
A	33350177	33350176	33350175	33349598	1
B	-	-	-	35083309	1
2 Way					
A	33350180	33350179	33350178	33349600	2
3 Way					
A	33350183	33350182	33350181	33350072	3

** Available configurations with associated BOM (Bill Of Materials).

DIMENSION MEASUREMENT SAMPLE

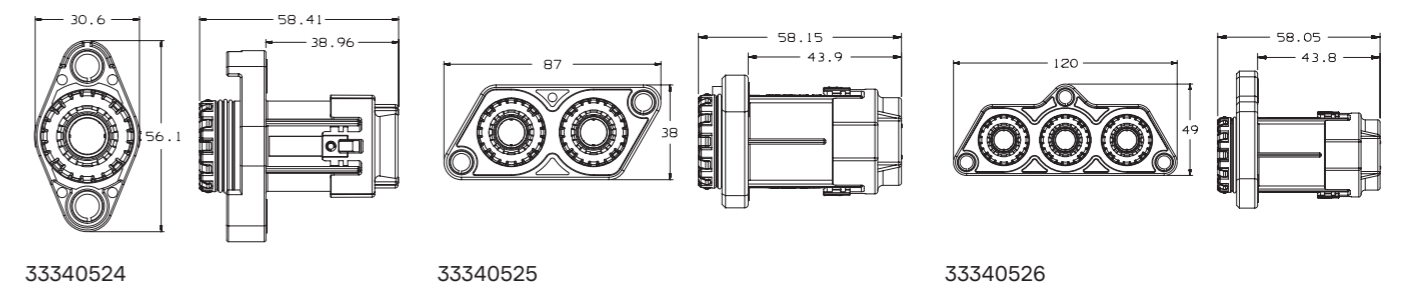

SHIELDPACK™

HV METAL PASS-THROUGH SI

25-50mm² 1 WAY



BENEFITS

- Robust design for harsh environments
- Very compact dimensions
- Wide variety of indexes depending on wire sections

FEATURES

- High voltage panel mount system
- 1 Way sealed and shielded solution
- Ring terminal bolted to device

APPLICATIONS

- AC / DC inverter
- HV battery
- HV PDU
- Power electric box
- E-motor

AVAILABLE CONFIGURATIONS

Connector Type	Pass-through
Cable Exit Orientation	180°
Cable Range (mm ²)	25 - 50 (power)
Terminal Type	Ring
# of Power Terminals	1
Shielding	Individual
HVIL	None
Number of Indexes	6-8, depending on wire section

PERFORMANCE

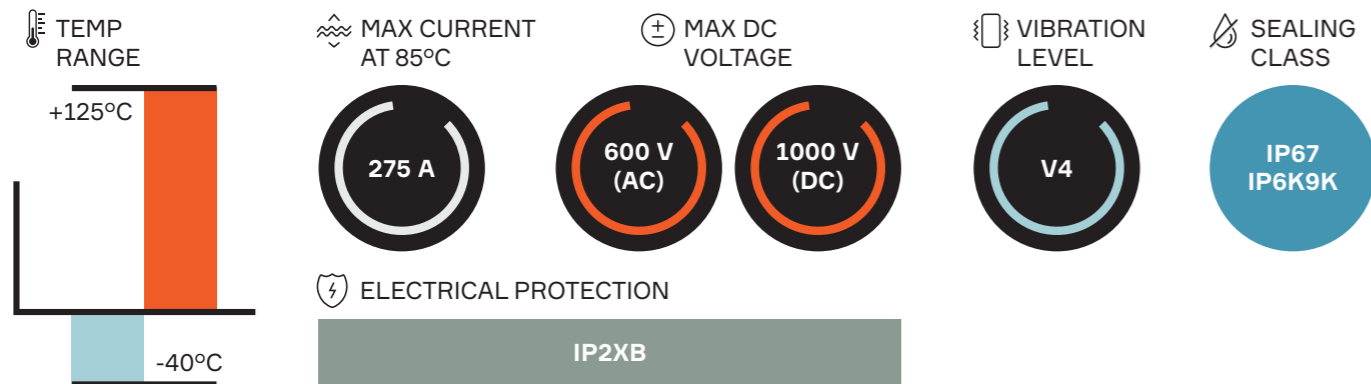

Main Housing Body Components

Index	25 mm ² wire section	35 mm ² wire section	50 mm ² wire section	BOM
102	13888001	13894189	33112598	1
103	13888002	13894190	33112599	
104	13888003	13894191	33112600	
105	13888004	13894192	33112601	
106	-	-	33112602	
107	-	-	33112608	
108	33253253	33253255	33112609	
109	33253254	33253256	33112610	

ASSOCIATED PARTS

Part number	Description	Part number	Description	Part number	Description
25 mm²		35 mm²		50 mm²	
13888023	25 mm ² seal retainer	13894241	35 mm ² seal retainer	33112613	50 mm ² seal retainer
13888030	25 mm ² seal	33288396	35 mm ² seal	33112616	50 mm ² seal
13888025	O-ring seal	13888025	O-ring seal	13888025	O-ring seal
33295901	25 mm ² ferrule	33295902	35 mm ² ferrule	33295903	50 mm ² ferrule

DIMENSION MEASUREMENT SAMPLE

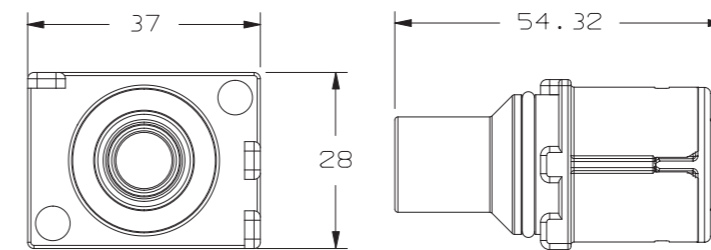

13888001

Part numbers, specifications, dimensions and performance data in this document are for general references only and are subject to change without notice. To verify product information, please contact an Aptiv representative.

SHIELDPACK™

HV PLASTIC PASS-THROUGH SI

50-70mm² 2 WAY

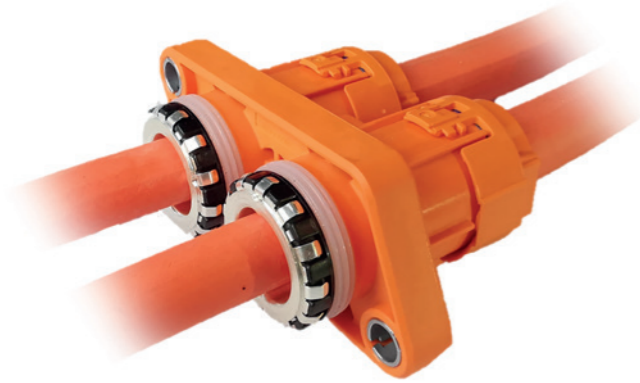

BENEFITS

- High operating temperature
- Enhanced anti-vibration performance
- Very compact dimensions

FEATURES

- For applications with needs up to 330A
- Compliant to USCAR-2 / USCAR-37
- Plastic main housing frame with stamped shielding terminals
- Anti-rotation shielding components with extra safeguard for 70 mm² cables
- Compatible with ring terminal bolted to device

AVAILABLE CONFIGURATIONS

Connector Type	Pass-through
Cable Exit Orientation	180°
Cable Range (mm ²)	50 / 70
Terminal Type	Ring Terminals
# of Cavities	2
Shielding	Individual
HVIL	None
Assembly Assurance	Screw Position Assurance
# of Code Indexes	1

APPLICATIONS

- Powertrain High Voltage / Current Modules:
- Power Converter / Inverter
- E-motor
- PDU / BDU

PERFORMANCE

TEMP RANGE

+140°C

-40°C

MAX CURRENT AT 85°C

330 A

MAX DC VOLTAGE

1000 V

VIBRATION LEVEL

V3

SEALING CLASS

IP67
IP6K9K

ELECTRICAL PROTECTION

IPXXB

Index	Pass-through Connector		BOM
	2 Screw Version	3 Screw Version	
A	35197716	35197715	1

Additional codes or mirrored versions are offered on demand. Contact an Aptiv representative for details.

ASSOCIATED PARTS

LV Cable	Part number		Description	BOM
	ISO Cable			
	35516040 or equivalent		Ring Terminal / Tubular Lug	2
	Please contact your Aptiv representative		Sonic Weld Ring Terminal	
	35197711		Shielding Terminal	2
35197311		35434228	Shielding Outer Ferrule	2
		35197273	Peripheral Seal	2
35197279		35434214	Cable Seal	2
35197706		35434216	Cable Strain Relief	2
35207823		35434229	Anti-rotation Safeguard	2

Additional validation is required when using with other terminals. 50 mm² parts are offered on demand, and AK Pass-through products are recommended if only 50 mm² is needed. Sonic weld ring terminal is a user customized part. Please contact an Aptiv representative for more information.

DIMENSION MEASUREMENT SAMPLE

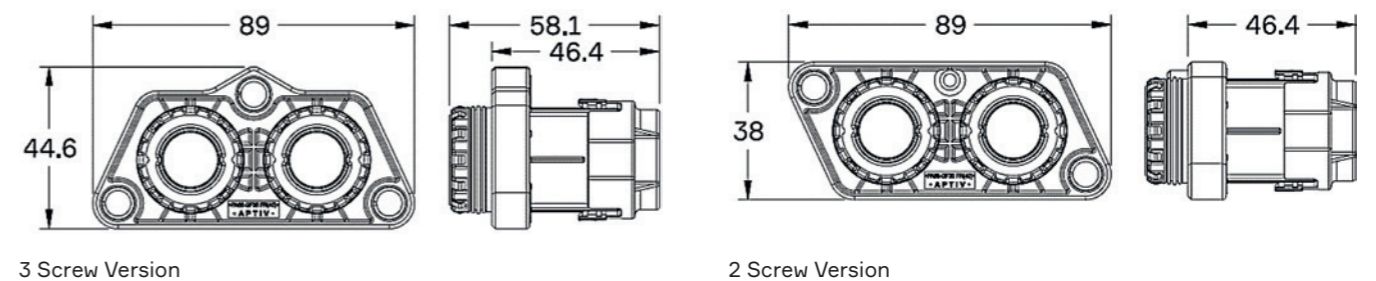

SHIELDPACK™

HV METAL PASS-THROUGH SI

70-95mm² 1 WAY



BENEFITS

- High operating temperature
- Applicable under extreme vibration
- Robust design for harsh environments
- Very compact dimensions

FEATURES

- For applications with needs up to 400A
- Compliant to USCAR-2 / USCAR-37
- High voltage panel mount system
- Die-casting housing
- Compatible with ring terminal bolted to device

APPLICATIONS

- Powertrain High Voltage / Current Modules:
- Power Converter / Inverter
- E-motor
- PDU / BDU

AVAILABLE CONFIGURATIONS

Connector Type	Pass-through
Cable Exit Orientation	180°
Cable Range (mm ²)	70 / 95
Terminal Type	Ring Terminals
# of Cavities	1
Shielding	Individual
HVIL	None
Assembly Assurance	Screw Position Assurance
# of Code Indexes	6

PERFORMANCE

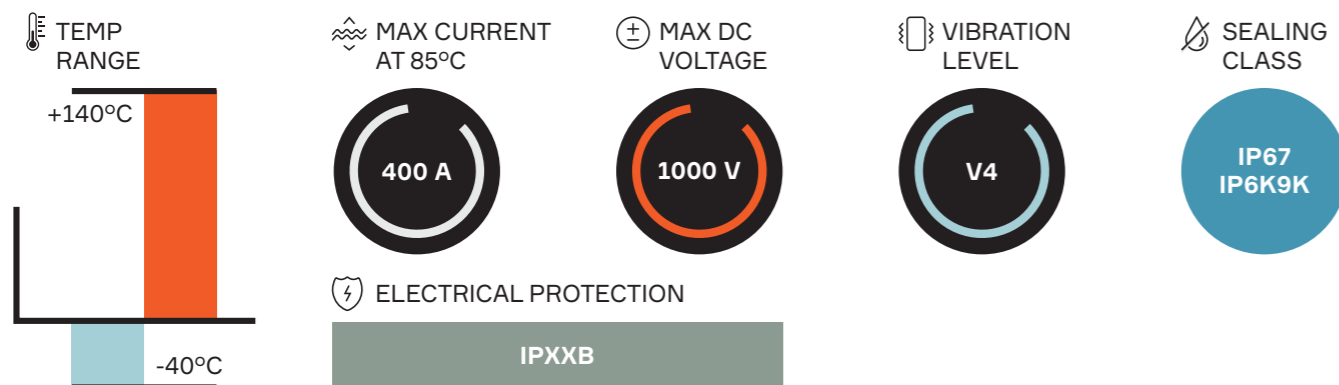

Index	Pass-through Connector		BOM
	70 mm ² Cable	95 mm ² Cable	
101	35274900	35255189	1
102	35274901	35235654	
103	35274902	35235980	
104	35274903	35235981	
108	35274904	35235982	
109	35274905	35235983	

ASSOCIATED PARTS

Part number		Description	BOM
70 mm ² Cable	95 mm ² Cable		
35516040 or equivalent	35516043 or equivalent	Ring Terminal / Tubular Lug	1
Please contact your Aptiv representative		Sonic Weld Ring Terminal	
35274906	35235653	Ferrule	1
35235632		O-Ring Seal	1
35274909	35235651	Cable Seal	1
35274908	35235652	Lock Retainer	1

Additional validation is required when using with other terminals. Sonic weld ring terminal is a user customized part. Please contact an Aptiv representative for more information.

DIMENSION MEASUREMENT SAMPLE

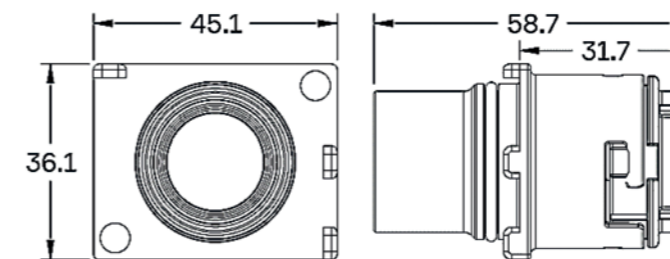

All Connectors

Part numbers, specifications, dimensions and performance data in this document are for general references only and are subject to change without notice. To verify product information, please contact an Aptiv representative.

SHIELDPACK™

HV PLASTIC PASS-THROUGH SI

95-120mm² 1 AND 2 WAY



BENEFITS

- Plastic main housing frame
- Terminal Size/Style: Ring/Tongue

FEATURES

- High operating temperature
- High robustness against vibrations
- Solution for demands on 120 mm²
- More operation-friendly cable anti-rotation feature

APPLICATIONS

- Powertrain High Voltage / Current Modules:
- Power Inverter/Converter
- E-motor
- PDU

AVAILABLE CONFIGURATIONS

Connector Type	Pass-through
Cable Exit Orientation	180°
Cable Range (mm ²)	95 - 120
Terminal Type	Ring/Tongue
# of Power Terminals	1W & 2W
Shielding	360° Shielding
HVIL	None
# of Indexes	1

PERFORMANCE

TEMP RANGE

+140°C

-40°C

MAX CURRENT AT 85°C

420A (with 95 mm²)

MAX DC VOLTAGE

1000 V

VIBRATION LEVEL

V3

SEALING CLASS

IP67
IP6K9K

ELECTRICAL PROTECTION

IPXXB

Main Housing Body Components

Code	Number of ways		BOM
	1	2	
A	35525372	35699674	1

ASSOCIATED PARTS

Description	1 Way		2 Way		BOM
	95 mm ²	120 mm ²	95 mm ²	120 mm ²	
Peripheral Face Seal	35525378		35699674		1 or 2
Single Wire Seal (M6371)	35525381	35525380	35525381	35525380	1 or 2
Protection Cover Assy	35525384	35525383	35525384	35525383	1 or 2
Shielding Outer Ferrule	35525391	35525390	35525391	35525390	1 or 2
ASM Shield Terminal	35525392				1 or 2
Ring Terminal	35617874				1 or 2

DIMENSION MEASUREMENT SAMPLE

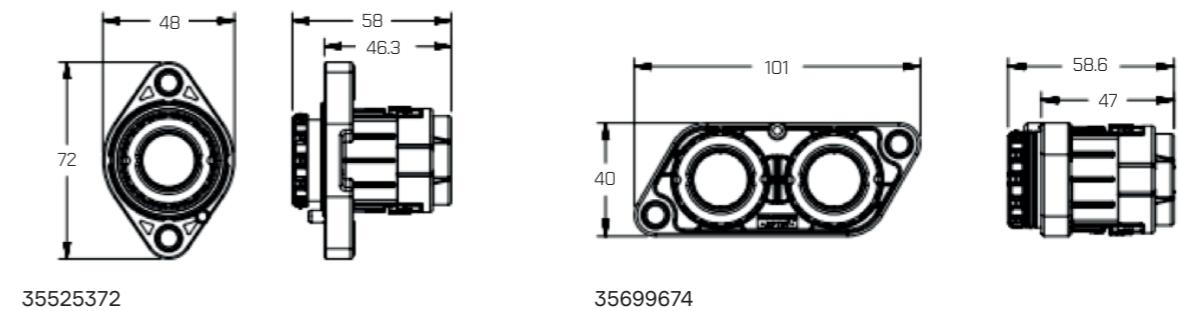

Part numbers, specifications, dimensions and performance data in this document are for general references only and are subject to change without notice. To verify product information, please contact an Aptiv representative.

12, 24 & 48 Volt Solutions

SELECTOR GUIDE

APPLICATIONS:

- 48V electrical centers
- Power distribution boxes
- Start-stop systems
- E-turbo
- Battery
- Active suspension
- BSG units
- High current harness and devices
- Sealed pass-through panel mount systems



Application	48V electrical centers, Power distribution boxes, Start-stop systems, E-turbo, Battery, Active suspension, BSG units
Description	POWERPACK 48V SEALED RING CONNECTOR
Amperage at 85°C	250 A
Voltage	12 - 48 V
Orientation	90°
# of Ways	1
Shielding	No
Vibration Class	V3
Temperature Class	T3
Sections	35 mm ² 50 mm ²
See Page	84 - 85

High current harnesses and devices, Sealed pass-through panel mount systems			
POWERPACK LV 1000 INLINE	POWERPACK LV 1000 INLINE CONNECTOR	POWER PACK LV1000 DEVICE	POWERPACK LV 2000 INLINE CONNECTOR 1 WAY
	120 A		210 A
	12 - 48 V		48 V
180°	180°	90°	180°
	1 & 2		1
	No		No
	V2		V1
	T3		T3
	8 - 25 mm ²		16 - 35 mm ²
	86 - 87		88 - 89

POWERPACK

48V SEALED RING CONNECTOR

1 WAY



BENEFITS

- Fast and easy assembly process
- High robustness against vibrations
- High current carrying capabilities

FEATURES

- Ideal solution for 12 to 48V requiring sealed ring connections
- Can be screwed from the top
- Header interface available for system supplier integration on the box
- M8 ring terminal bolted to device

APPLICATIONS

- 48V electrical centers
- Power distribution boxes
- Start-stop systems
- E-turbo
- Battery
- Active suspension
- BSG units

AVAILABLE CONFIGURATIONS

Connector Type	Wire-to-device
Cable Exit Orientation	90°
Cable Range (mm ²)	35, 50
Terminal Type	M8 ring terminal
# of Power Terminals	1
Shielding Type	Unshielded
HVIL	None
Assembly Assurance	None
Number of Indexes	2

PERFORMANCE

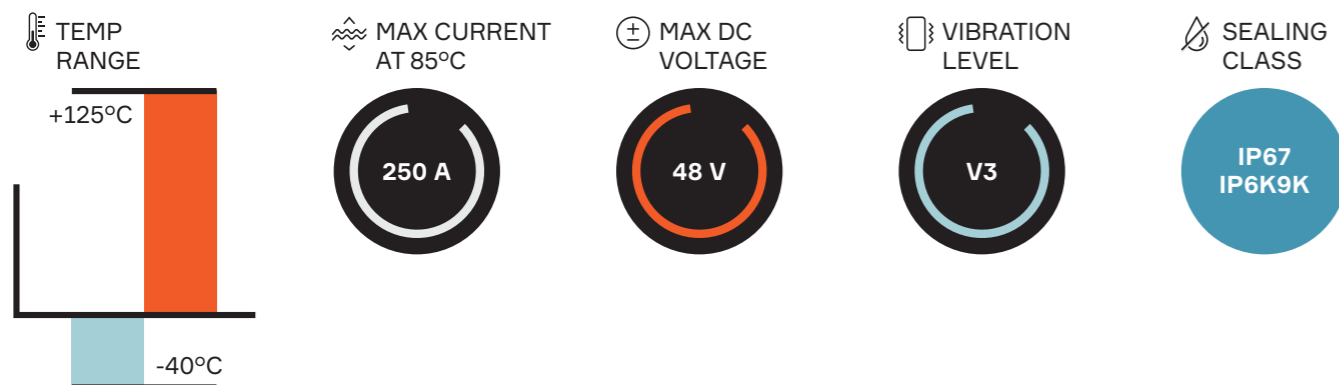

Code	Mating connector	Header connector	BOM
A	33376962	Please contact your Aptiv representative for more information	1
B	33376953	Please contact your Aptiv representative for more information	1

ASSOCIATED PARTS

Part number	Type	Applicable wire size (mm ²)	Cable type	BOM
33376821	Single wire seal retainer	35 - 50	-	2
33329995	M8 O-ring terminal	35 - 50	-	1
35093138	Single wire seal	35	Unshielded	1

DIMENSION MEASUREMENT SAMPLE

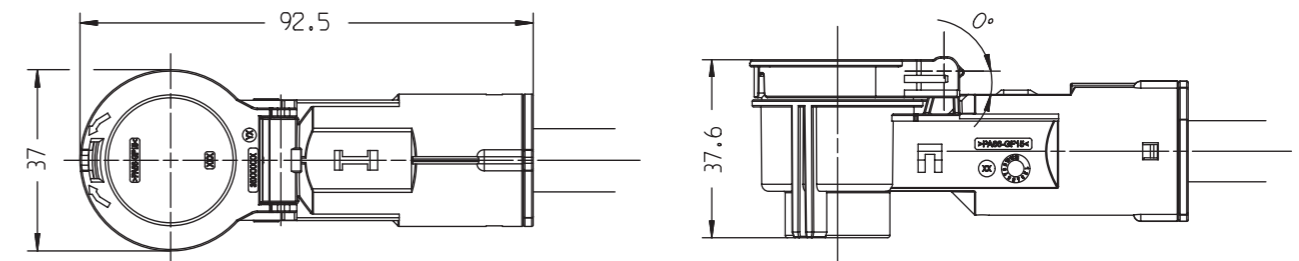

33376962

Part numbers, specifications, dimensions and performance data in this document are for general references only and are subject to change without notice. To verify product information, please contact an Aptiv representative.

POWERPACK

LV1000 1 AND 2 WAY

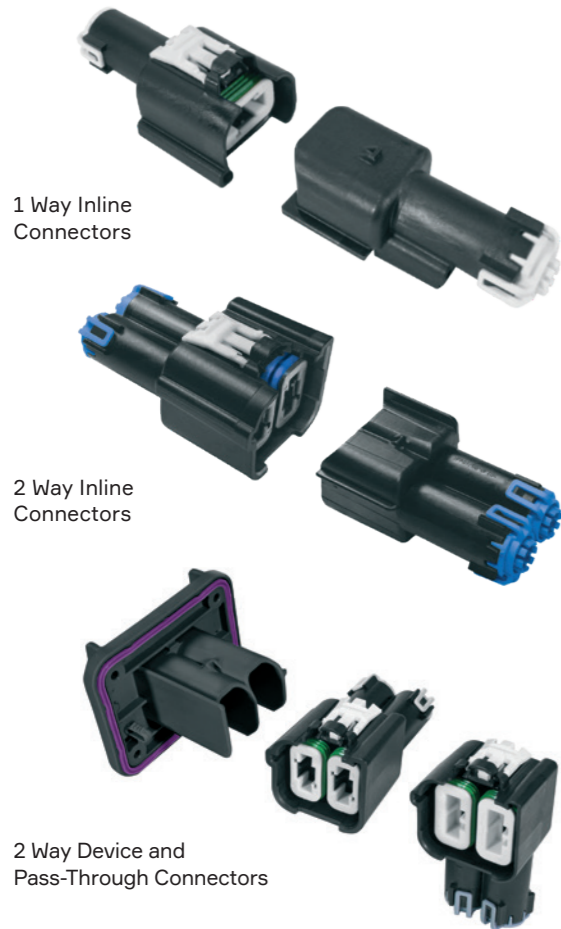

BENEFITS

- High current carrying capacity
- Proven terminal system
- Compact system design
- Field proven in both automotive and heavy duty applications

FEATURES

- Silver-plated multi-contact terminal system
- Sealed panel mount pre-stages prior to fastening
- Panel mount secured in place with self-tapping screws
- Pass-through connection accepts both straight and right angle connectors

AVAILABLE CONFIGURATIONS

Connector Type	Wire-to-device, wire-to-wire, pass-through
Cable Exit Orientation	180°, 90°
Cable Range (mm ²)	8 - 25
Terminal Type	Power Pack 1000
# of Power Terminals	1 or 2
Shielding Type	Unshielded
HVIL	None
Assembly Assurance	None
Number of Indexes	2

APPLICATIONS

- High current harnesses and devices
- Sealed pass-through panel mount systems

PERFORMANCE

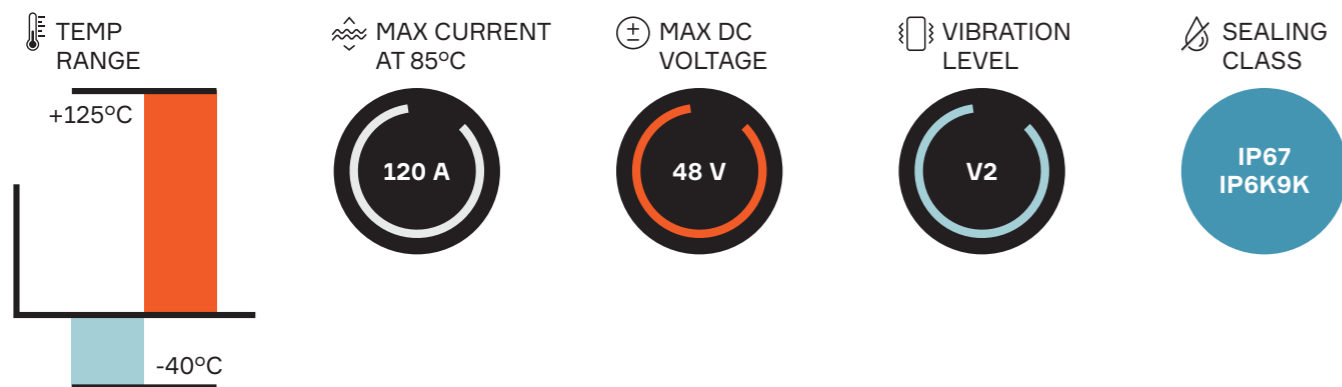

1 Way Inline Connectors

Male connector	Mating connector	BOM
13882980	13952702	1

2 Way Inline Connectors

Index	Male connector	Mating connector	BOM
103	13849747	13849756	1
104	13849748	13849757	

2 Way Device and Pass-Through Connectors

Index	Header connector	Mating connector		BOM
		180°	90°	
103	13959824	13849756	13849758	1

ASSOCIATED PARTS

Part number	Description	BOM
Header / Male inline		
13675577	PP1000 silver-plated 8 - 10 mm ²	1
13675579	PP1000 silver-plated 19 - 25 mm ²	
Mating connector		
13675583	PP1000 silver-plated 8 - 10 mm ²	1
13675585	PP1000 silver-plated 19 - 25 mm ²	
Seals and Retainers*		
13675510	Cable seal PP1000 4.54 - 5.79 dia cable (grey) 8 - 10 mm ²	1
13675513	Cable seal PP1000 1.01 - 9.19 dia cable (blue) 19 - 25 mm ²	
13849785	Cable seal retainer PP1000 8 - 10 mm ²	1
13849788	Cable seal retainer PP1000 19 - 25 mm ²	

* For both header, male inline + mating connector

DIMENSION MEASUREMENT SAMPLE

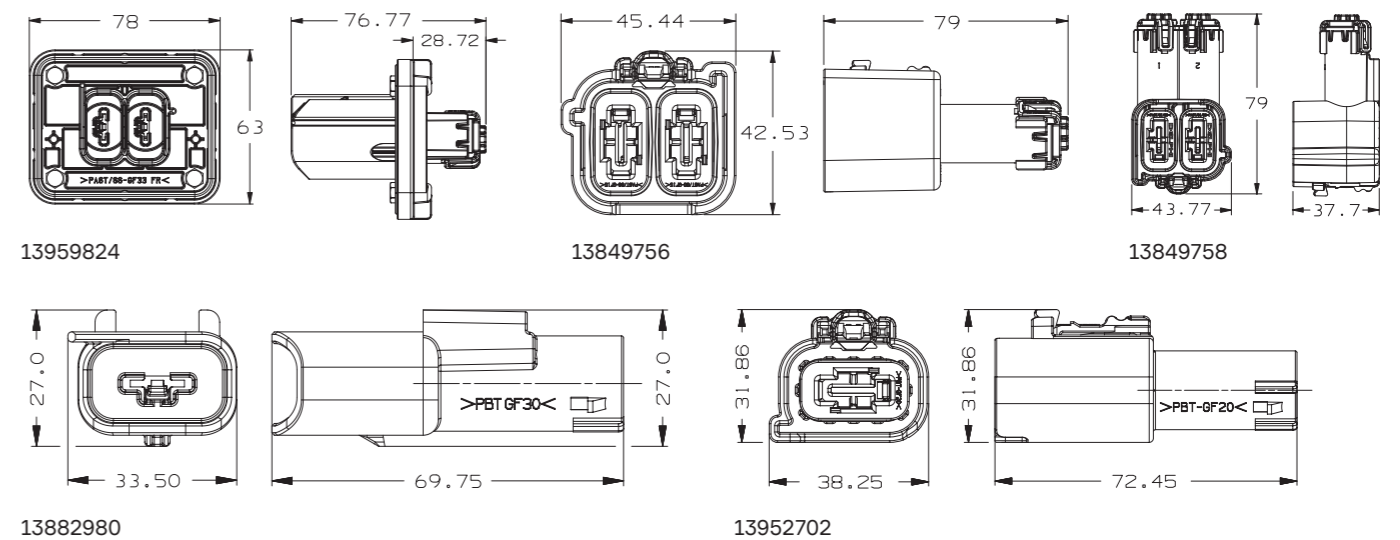

Part numbers, specifications, dimensions and performance data in this document are for general references only and are subject to change without notice. To verify product information, please contact an Aptiv representative.

POWERPACK

LV 2000 INLINE CONNECTOR

1 WAY



BENEFITS

- High current carrying capacity
- PP 2000 proven terminal system
- Compact system design
- Very few parts to assemble

FEATURES

- Up to 35 mm² cross sections
- For applications with needs up to 210A
- Silver-plated multi-contact terminal system
- Ultrasonic weld connection for higher amperage performances

APPLICATIONS

48V Applications:
High Current Harnesses & Devices

AVAILABLE CONFIGURATIONS

Connector Type	Wire-to-device
Cable Exit Orientation	180°
Cable Range (mm ²)	16, 25, 35
Terminal Type	17.7 mm Blade Contact
# of Cavities	1
Assembly Assurance	CPA
# of Code Indexes	2

PERFORMANCE

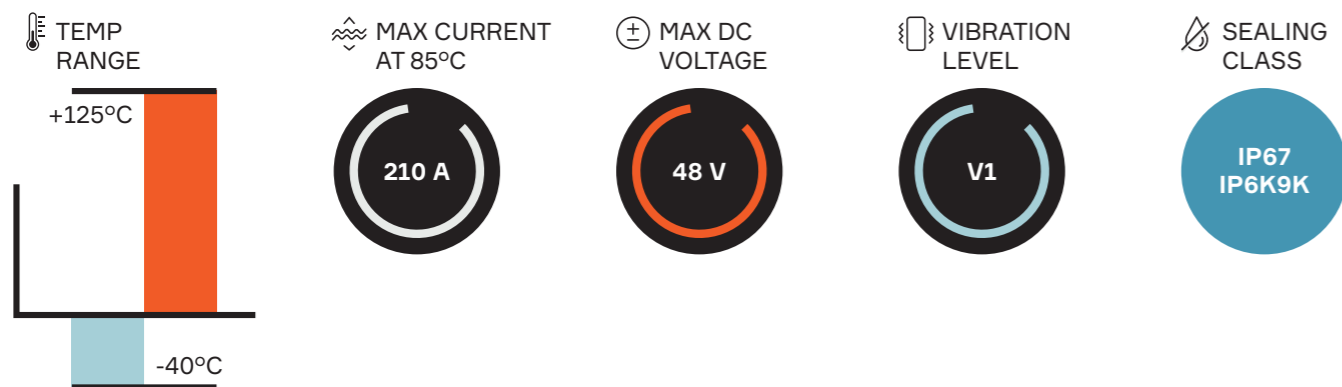

Index	Inline Male Connector	Inline Female Connector	BOM
101	35191198	35191203	1
102	35191202	35191204	

ASSOCIATED PARTS

16 mm ² Cable	25 mm ² Cable	35 mm ² Cable	Description	BOM
Inline male connector				
	35228529		PP 2000 180° Sonic Weld Male Terminal	1
35191210	35191211	35191212	Cable Seal	1
35191213	35191214	35191215	Seal Retainer	1
Mating connector				
	13815981		PP 2000 180° Sonic Weld Female Terminal	1
35191210	35191211	35191212	Cable Seal	1
35191213	35191214	35191215	Seal Retainer	1

DIMENSION MEASUREMENT SAMPLE

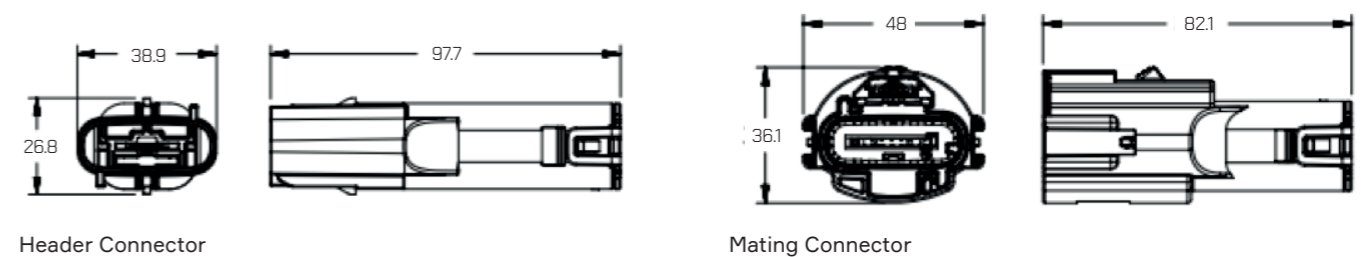

Part numbers, specifications, dimensions and performance data in this document are for general references only and are subject to change without notice. To verify product information, please contact an Aptiv representative.

Charging Solutions

SELECTOR GUIDE

APPLICATIONS:

- On-vehicle charging inlets
- Grid-to-vehicle charging
- Charging infrastructure-to-vehicle



Application	Cable assemblies for integration into charging stations	Charging between vehicle and charge station	Grid to vehicle charging
Description	TYPE II CHARGING PIGTAILS	MODE 3 CHARGING CABLE	MODE 2 CHARGING CABLE
Mating cycles	10 000	10 000 / 14 000	10 000
# of phases	1 or 3	1 & 3	1
Amperage	20 - 32 A (AC)	20 - 32 A (AC)	6 - 14 A (AC)
Voltage	480 V (AC)	240 - 400 V (AC)	240 V (AC)
Cable length	3.5 - 8 m	3.5 - 9 m	5 m
See Page	92 - 93	94 - 95	96 - 97

TYPE II CHARGING PIGTAILS



BENEFITS

- Robust handling with graining plastic shell
- Screwless system assembly to optimize robustness
- Cost effective design to inlet and wallbox

FEATURES

- Available in different power and cable length option
- Wiring crimps sealed from environment
- IEC62196-2 Type II connector EN17186 and Type II standards

APPLICATIONS

- Grid-to-vehicle
- Infrastructure to electric vehicle charging

TECHNICAL CHARACTERISTICS

Mating Cycles 10 000

AVAILABLE CONFIGURATIONS

Design	Plastic handle
Outlet Standard	IEC62196-2 Type II CE marking / third part certification CE / EN17186 / UKCA / Morocco / Ukraine / Australia / NZ

PERFORMANCE

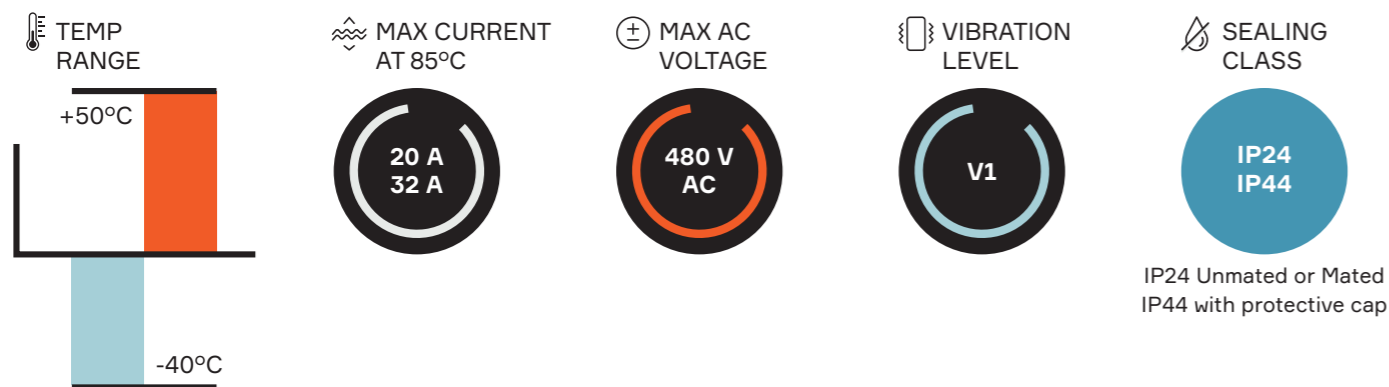

Part number	Type (veh/wall)	Design	Current	# Phase	Cable Length	Certification
35622693	Type II	Screwless Shells, Stamped Terminals	20A	1-phase	5	CE
35622691	Type II	Screwless Shells, Stamped Terminals	32A	1-phase	5	CE
35636480	Type II	Screwless Shells, Stamped Terminals	20A	3-phase	3.5	CE
35622694	Type II	Screwless Shells, Stamped Terminals	20A	3-phase	5	CE
35636482	Type II	Screwless Shells, Stamped Terminals	20A	3-phase	8	CE
35622692	Type II	Screwless Shells, Stamped Terminals	32A	3-phase	5	CE

For more specific information, please contact your Aptiv representative.

COMPATIBLE WITH



IEC62196 Type II Inlet

DIMENSION MEASUREMENT SAMPLE

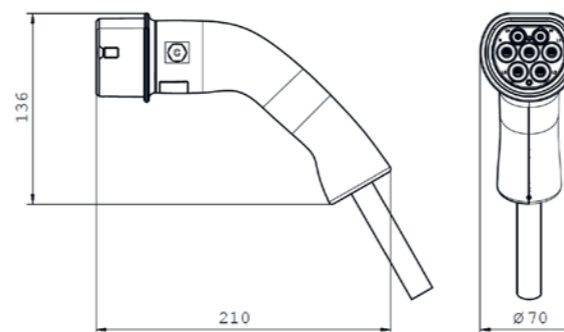

Part numbers, specifications, dimensions and performance data in this document are for general references only and are subject to change without notice. To verify product information, please contact an Aptiv representative.

MODE 3 CHARGING CABLE



BENEFITS

- Superior durability and proven in automotive mass production
- Wiring crimps sealed from environment
- CE and CQC marking/certification

FEATURES

- Vehicle connector according to IEC62196-2-2
- Superior durability: 14,000 cycles (while IEC standard only requires 10,000 cycles)
- Low mating/unmating forces: Initial < 40N, Mating forces < 80N guaranteed until 14,000 cycles

APPLICATIONS

Cable assemblies for plugging from charging stations to vehicle

AVAILABLE CONFIGURATIONS

Design	Plastic handle
Outlet Standard	CE, CQC
Configurations	Type II - Type II

TECHNICAL CHARACTERISTICS

Mating Cycles 14 000 (CE Products),
10 000 (CQC Products)

PERFORMANCE

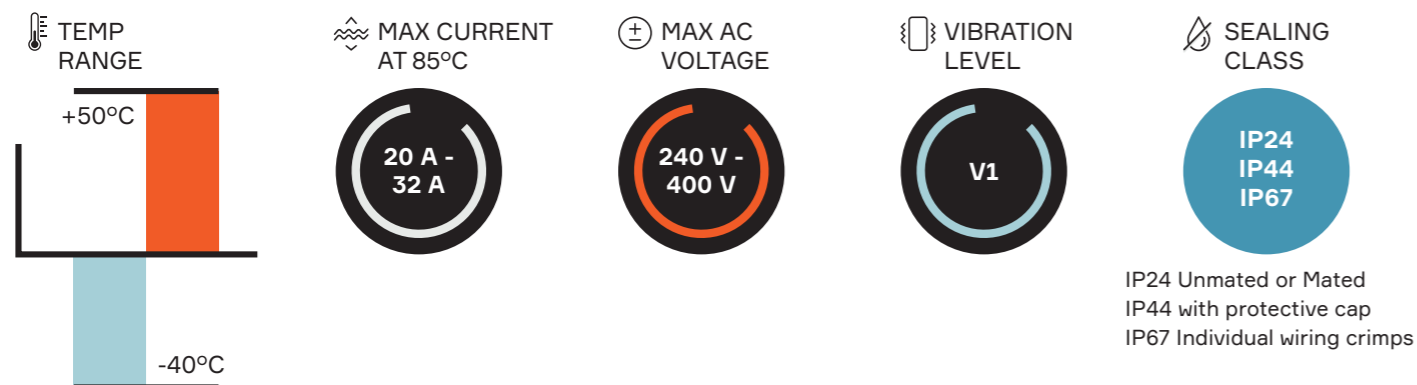

Part number	Type (veh/wall)	Current	# Phase	Cable length (m)*	Option**
35741698	Jumper Type II - Type II	20A	3-phase	5	With dust cap
35741702		20A	3-phase	7	
35741651		32A	3-phase	5	
35741668		32A	3-phase	7	
35741717		20A	1-phase	5	
35741724		20A	1-phase	7	
35741685		32A	1-phase	5	
35741690		32A	1-phase	7	

*Other lengths available (from 3,50 to 9 m) please consult us

**Versions without dust cap available on request

COMPATIBLE WITH



IEC62196 Type II Inlet

DIMENSION MEASUREMENT SAMPLE



Part numbers, specifications, dimensions and performance data in this document are for general references only and are subject to change without notice. To verify product information, please contact an Aptiv representative.

MODE 2 CHARGING CABLE



BENEFITS

- Superior durability and proven in automotive mass production
- Dual-thermo sensors in the grid plug provide superior overheating protection
- Grid cord as required by country of use

FEATURES

- EVSE provides restart in the event of power grid fault
- Product according to IEC62752 standard including Type B RCD and residential DC current detection
- Superior control box water sealing protection: IP67 (higher than the standard)

APPLICATIONS

Portable Electric Vehicle Supply Equipment (EVSE) for grid-to-vehicle charging

TECHNICAL CHARACTERISTICS

Mating Cycles 10 000

AVAILABLE CONFIGURATIONS

Design	Rubber overmold
Inlet Standard	SAE J1772 Type I IEC62196 Type II GB/T

PERFORMANCE

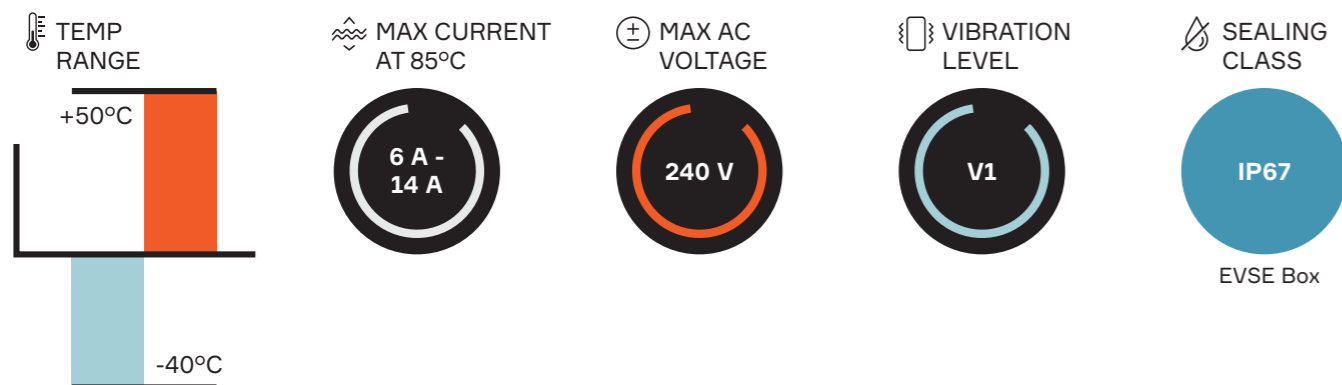

Part number	Type (veh/wall)	Current	# Phase	Cable length (m / In.)	Countries*	Certification
35054780	Type II	10A	1-phase	5.0 / 16.4	Europe (Germany, France...)	CE
35086913		8A			Finland	
35054781		10A			UK, Ireland, Cyprus, Malta	
35058252		6A			Denmark	
35054782		8A			Switzerland	
35054784		10A			Norway	
35054788		8A			Italy	
35268956		14A			Europe - Grid plug CEE 16/3	
35054779		Type I			10A	
35268957	GB/T	8A	China	GB/T 20234		

* Other countries outside Europe also available.

COMPATIBLE WITH



DIMENSION MEASUREMENT SAMPLE

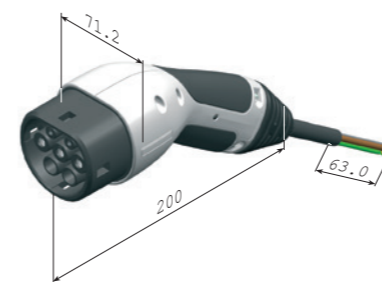

Type II Rubber Over Mold

Part numbers, specifications, dimensions and performance data in this document are for general references only and are subject to change without notice. To verify product information, please contact an Aptiv representative.

Notes

Handwriting practice area with horizontal dotted lines.

Handwriting practice area with horizontal dotted lines.

For **more** information:

Visit our website: aptiv.com

Browse our E-catalog: aptiv.com/en/solutions/connection-systems

Contact your local distributor:

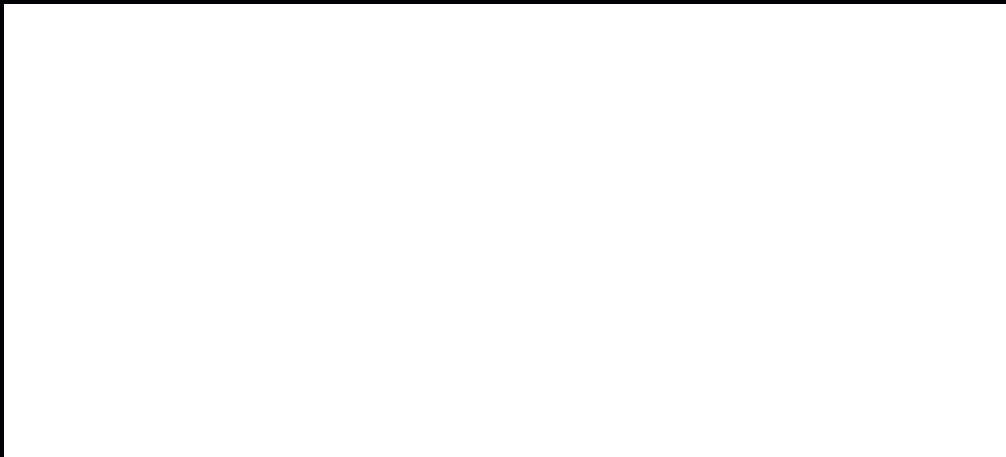

Asia Pacific
Regional Operations

200 Yuanguo Road
Anting, Jiading District
Shanghai, 201814 China
Tel: (86) 21.5956.2200

Europe
Customer Center

ZI des longs Réages,
28230 Épernon
France
Tel: (33) 237.187.600
Germany
Tel: (49) 202.291.0

North America
Customer Center

5725 Innovation Drive
Troy, Michigan 48098-2815
USA
Tel: (1) 248.813.2000

South America
Regional Operations

APTIV Automotive Systems
do Brasil Ltda.
Rod. dos Tamoios, Km 21,8
Jambeiro, Sao Paulo
12270-000 Brazil
Tel: (55) 12.3978.2098