

Pyrofuse Sealed Squib Connectors



PRODUCT BENEFITS

- The only fully serviceable sealed connector in the market
- Suitable solution for application in harsh environment and outside of the passenger compartment

SERIES FEATURES

- One-piece terminal, selectively gold-plated
- Sealed connector
- Delivered in different wire lengths and types
- Superior lifetime stability through resistance welded wires

TECHNICAL CHARACTERISTICS

Interface	FCI
Serviceability	Serviceable
EMI filtering device	Ferrite
Locking type	Active CPA*
Termination technology	Welding
Scoop-proof interface	No

APPLICATIONS

Engine compartment
Battery cut-off
Harsh environment

See back page for representative part numbers and packaging dimensions.

TEMPERATURE



SEALING

acc. to
LV 214 PG23

CONTACT RESISTANCE

< 15 mΩ

DIELECTRIC TEST

750V/DC

PULL-OUT FORCE

> 150 N

About Aptiv

Aptiv is a global technology company that develops safer, greener and more connected solutions, which enable the future of mobility. Headquartered in Dublin, Aptiv has 147,000 employees and operates 14 technical centers, as well as manufacturing sites and customer support centers in 45 countries.

Visit aptiv.com



* Connector Position Assurance



Product code	FFW90-1
Interface	FCI
Available codings	B
Compatible wire size	0.5 mm ²

For the matching part numbers and user specified pigtail wire length, wire gauge and wire type, please contact your Aptiv representatives.



DIMENSION MEASUREMENT SAMPLE

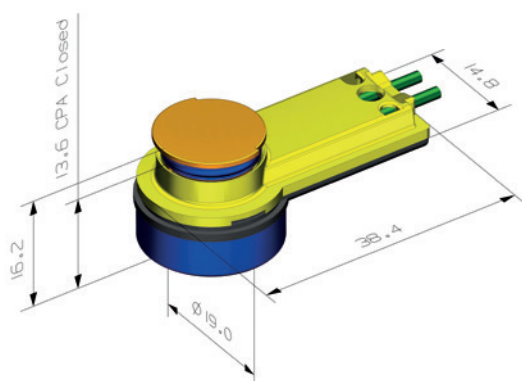

The dimensions are in mm.



MATES WITH

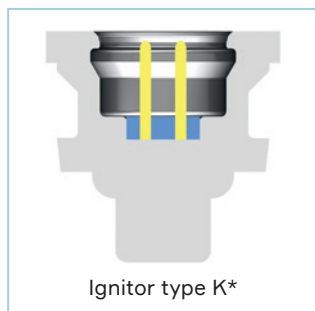
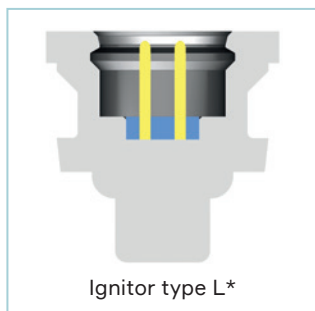

* Ignitors are not manufactured by Aptiv, please contact your usual supplier.

Part numbers, specifications, dimensions and performance data in this document are for general references only and are subject to change without notice. To verify product information, please contact an Aptiv representative.