

• APTIV •

# A CONNECTOR CAN SAVE YOUR LIFE

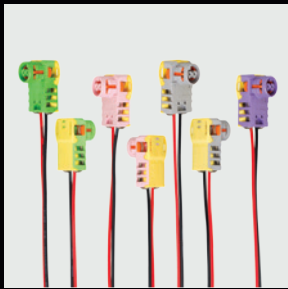

## SAFETY RESTRAINT SYSTEMS (SRS)

Interconnect solutions for airbags and other pyrotechnic devices



# At Aptiv, we are born to move

Aptiv is a **global technology company** that develops safer, greener and more connected solutions enabling the future of mobility.

Headquartered in Dublin, Aptiv has approximately 150,000 employees and operates 14 technical centers, as well as manufacturing sites and customer support centers in 45 countries.

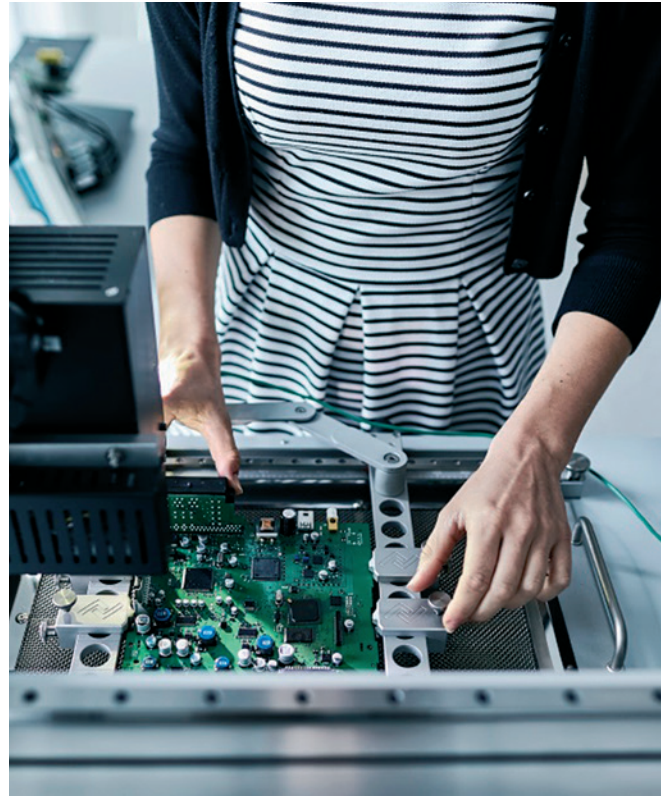

**VISIT [APTIV.COM](https://www.aptiv.com)** →

## Major Design Centers Worldwide





# A spark of time that requires the best of **our technology**

**Less than 50 milliseconds** is the time it takes for an airbag to inflate. Because your life can depend on that ‘spark’ of time, Aptiv brings its vehicle systems know-how and technology to provide you the most advanced safety restraint interconnect solutions.

Aptiv is proud to offer the world’s most trusted solutions for connecting wiring systems to airbags and other pyrotechnic devices used in vehicles.

Firmly established as one of the world’s leading suppliers in the automotive SRS market, Aptiv has developed most of the major interface standards and innovations used in the industry today. Our success is based on a number of important customer benefits, including:

- One of the broadest product ranges available
- Outstanding product features and performance
- Flexibility to meet your specific configuration, from connector pigtails to jumper harnesses
- Strong global manufacturing and supply chain capabilities



## Did you know?

**Squib connectors** are used to connect wiring to pyrotechnic devices, such as airbags, belt pre-tensioners, knee bolsters and pedestrian safety devices.

It all started with one airbag and connector in the 1970's and has grown to nearly 30 connectors in a high-end luxury model vehicle. According to our analysis, there is an average of 10 squib connectors per vehicle today. The vast majority of them are made by Aptiv.

- Driver Airbag
- Passenger Airbag
- Side Airbag
- Curtain Airbag
- Knee Airbag
- Belt Pretensioners
- Pedestrian Protection (Active Hood)
- Center Side Airbag
- Battery Cut Off

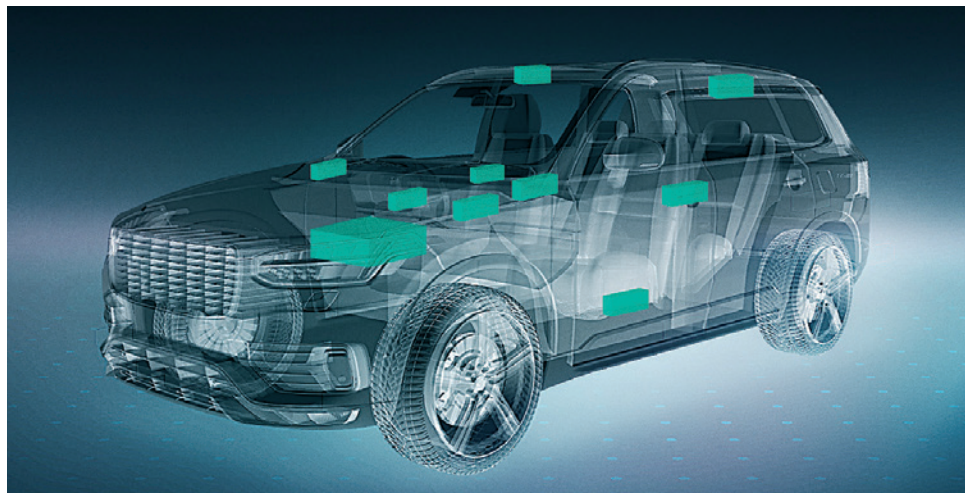

# It all starts with an innovative **connector**

Around the world, the automotive market is migrating to the **next generation** of interface standards.

The industry standard connection between the wiring harness and the airbag requires two parts: the retainer and the squib connector. The retainer, installed into the pocket of the ignitor, contains features necessary for a reliable connection to the squib connector, including indexing, pin protection, and, if required, a shorting clip. These design features encompass “the interface.”

Common market interfaces are:

## CURRENT/FUTURE STANDARDS

- ABX-5 interface (USCAR 999-U-002-1-Z03)
- AK-2 interface (ISO 19072-4)
- AK2+ interface (for Electro-Static Discharge issues)

## LEGACY STANDARDS

- FCI interface
- AK-1 interface
- UC interface
- J-AK interface

Aptiv has introduced various innovations to the market:

- The AK-2 interface, featuring the only true “Kojiri-safe” (scoop-proof) solution for inflators, has become a global standard, adopted by the main Standards organizations, such as ISO, AK and USCAR.
- The next generation ABX-5 interface takes all the benefits of the AK-2 interface and offers a connectivity solution without a shorting clip for the latest generation of airbag inflators.

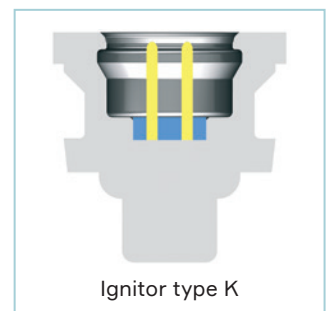

# Superior technology that saves lives and exceeds your expectations

## 1 Resistance welding

Resistance welding, as a replacement for the mechanical crimp of terminal to wire, has gained traction in the industry as the preferred connection technology for squib connectors. Superior mechanical and electrical stability over the lifetime is the major criteria for selecting this solution. Our products feature the benefits of resistance welding.



## 2 CES/CPA system

The patented Aptiv CES (Connector Engaged Safety) system employs the CPA (Connector Position Assurance) locking mechanism to create a reliable and safe mating process, ensuring a fully locked connector on the inflator. This valuable feature is the result of our best thinking over more than 20 years of experience supplying the industry.

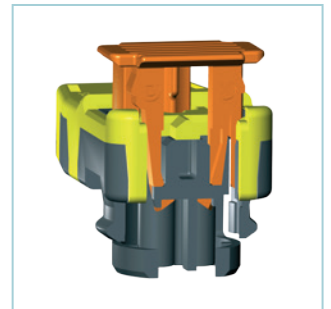

## 3 Shorting bar removal

Modern airbag modules are a lot more robust against electrostatic discharge (ESD). This opened the door to develop a new interface without shorting bar and created the ABX-5 connector family.



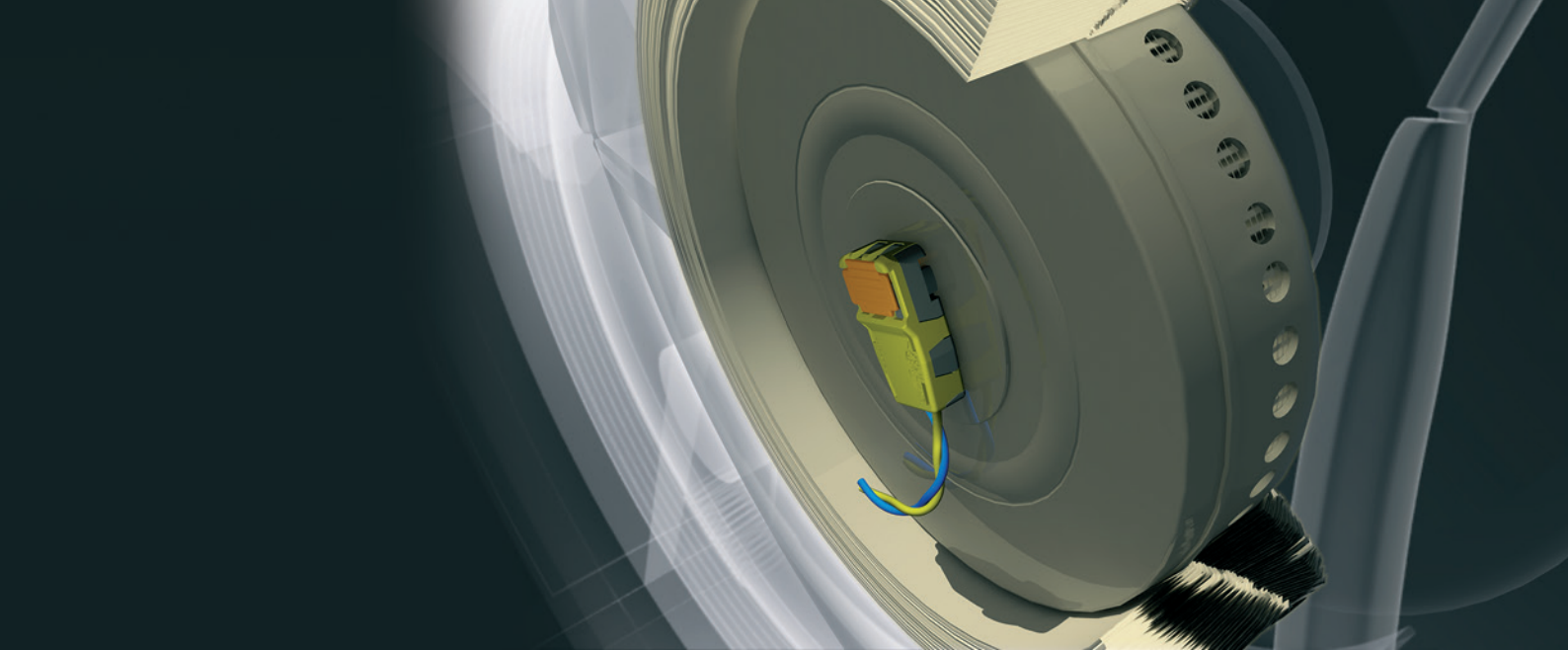

4

### ESD (Electro-Static Discharge) system

Aptiv offers a squib connector that incorporates a grounding lead. Airbag modules have to be grounded in many cases, which can be complicated and expensive. You can avoid using metal brackets or grounding straps if you introduce Aptiv's ESD system.

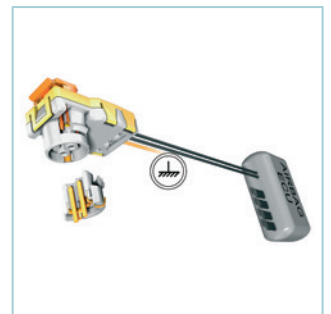

5

### Spring Lock connectors

A go/no-go adds a self-rejection feature to the connector design to give visible feedback if the connector has been mounted properly. Also the electrical connection will disconnect automatically when the connector has not reached the final locking position.



6

### Sealed applications

Squib connectors used for pedestrian protection or battery cutoff are often exposed to the harsh engine compartment environment. Aptiv has introduced connector solutions to help meet the specific requirements of these exposed pyrotechnic devices.



7

### The most compact products on the market

Space constraints can be a problem in the design of airbag modules, such as driver or side airbags. Aptiv has more than a decade of experience offering some of the most compact designs in the market. Ask about our low-profile connectors with less than 5 mm of protrusion.



# Reliability is a matter of wiring expertise

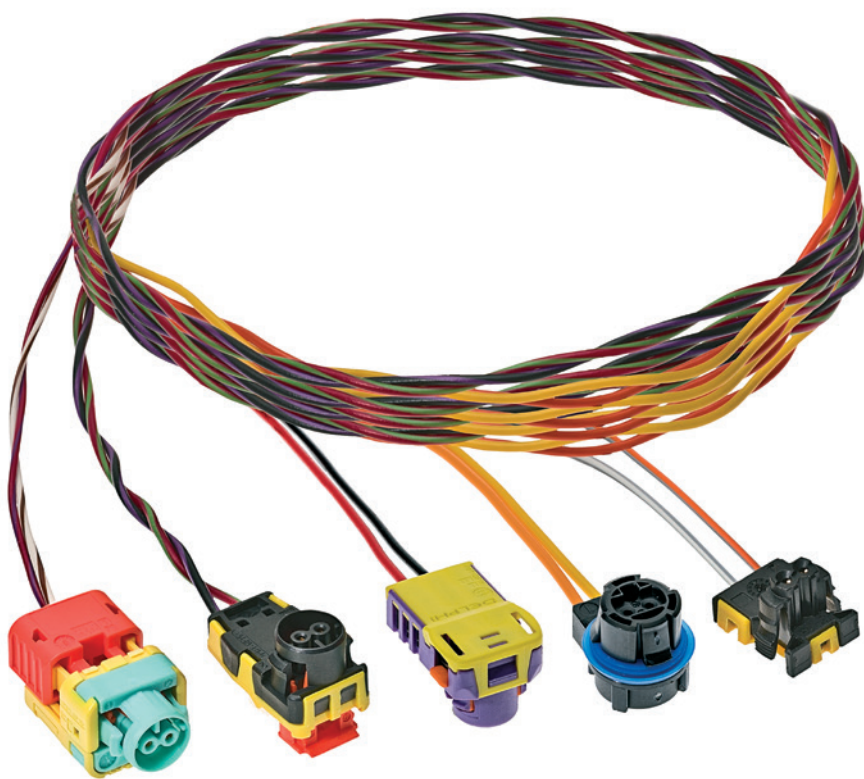

Aptiv brings technology together in a ready-to-use solution: **the “pigtail.”**

systems through stable resistance conditions and a monitoring function to indicate proper connection.

A pigtail is defined as a connector featuring a pre-attached length of wire. The user specifies the connector, and length, type and color of the wire. All of the critical internal connector assembly (wire termination, wire strain relief and cutting to length) is done for you.

Our manufacturing equipment has been tuned to a high level of reliability and efficiency over the years. This level of quality and completeness is exactly what is needed in safety and airbag circuits.

## The squib connector and pigtail

A squib connector must perform in all the customary automotive environments related to vibration, heat, assembly abuse and even harsh environment in certain applications. Unique to

airbag applications, the squib connection system must also possess circuit filtering capability, feature a small form factor for tight packaging, and cooperate with onboard diagnostic



## The advantages of a jumper harness

In other applications, such as side airbags in seats, it is more convenient to have wiring pre-assembled to the airbag and then shipped to the seat integrator.

Aptiv supports this with customizable jumper harness assemblies featuring the squib

connector at one end, a standard connector at the other, and attachment accessories in between. All shipped to the airbag manufacturer ready to connect. Whether your job is to supply the airbag, the vehicle wiring, or one of its modules, we will work with you to design the best solution.



AK-2+ Jumper

# A comprehensive product portfolio

1

## ABX-5: The successor to the current global AK-2 standard

- Reduction of system costs and higher robustness due to shorting bar removal from the retainer
- Available in a Spring Lock and CPA\* version featuring a simplified mating monitoring.
- 100% scoop-proof ABX-5 interface.



2

## AK-2: SRS best-in-class all-rounder

- Features a scoop-proof interface, noise filtering and shorting clip activation.
- Our most popular product is removable for service.
- An excellent general-purpose squib connector.



3

## Stay grounded with AK-2+ ESD\*\*

- 100% scoop-proof AK-2+ interface.
- Integrated grounding solution to eliminate potential misfiring caused by electrostatic discharge on the initiator.



4

## ABX-3: the space maker

- One of the smallest full-featured design on the market.
- Smaller form factor for applications with very tight space constraints.



\* Connector Position Assurance

\*\* Electro-Static Discharge

5

## Stay dry with our sealed connectors

- Cost effective UC solution not requiring a retainer.
- Connector and pigtail are handled as if part of the ignitor.
- Fully serviceable Pyrofuse solution for harsh environment, can be disassembled from the ignitor interface.
- Sealed performance for applications external to the cockpit.



6

## A full family of retainers

- Match with FCI, AK-1, AK-2, AK-2+ and ABX-5 interface connectors.
- Shorting bar protection for the ignitor excluding ABX-5.
- Different levels of scoop-proofing and indexing.



	Termination type	CES-CPA	Spring Lock	Scoop-proof	Sealed	Main features
<b>ABX-5</b>	Welding	Yes	Possible	Yes	No	No shorting clip
<b>AK-2</b>	Welding	Yes	Possible	Yes	No	Standard AK-2 product
<b>AK-2 ESD*</b>	Welding	Yes	No	Yes	No	Integrated grounding
<b>ABX-3</b>	Crimp	No	No	No	No	Miniaturized design
<b>ABX-UC sealed</b>	Welding	No	No	No	Yes	No retainer needed
<b>ABX-UC unsealed</b>	Crimp	No	No	No	No	No retainer needed
<b>Pyrofuse</b>	Welding	Yes	No	Improved	Yes	Sealed & serviceable

\* Electro-Static Discharge

**Asia Pacific**  
**Regional Operations**

200 Yuanguo Road  
Anting, Jiading District  
Shanghai, 201814 China  
Tel: (86) 21.3989.3000

**Europe**  
**Customer Center**

Rathsbergstrasse 25,  
Nuremberg 90411,  
Germany  
Tel: (49) 911 52720

**North America**  
**Customer Center**

5725 Innovation Drive  
Troy, Michigan 48098-2815  
USA  
Tel: (1) 248.813.2000

**South America**  
**Regional Operations**

Rod. dos Tamoios, Km 21,8  
Jambeiro, Sao Paulo  
12270-000 Brazil  
Tel: (55) 12.3978.2098

CS-SP55-SRS-En0924