

SICMA SEALED RELAY SOCKETS



SICMA Sealed Relay Socket 8W Female

BENEFITS

- Reliable connection to relay lasting throughout entire vehicle life cycle
- Easily disconnected and reconnected during relay change

FEATURES

- Sliding lever mate assist for easy mating to the relay switch
- Standard to different EOBD (European on Board Diagnostics) devices



AVAILABLE CONFIGURATIONS

Cavity Count (ways)	8
Cavity Configurations (mm)	2.8, 8.0
Material	PBT GF 15
Genders	Female
Sealing Type	Cable Sealed



APPLICATIONS

Pre-heating of diesel engines
Comfort heating of cockpit
Antipollution systems by EOBD

See back page for representative part numbers and packaging dimensions.



TEMPERATURE

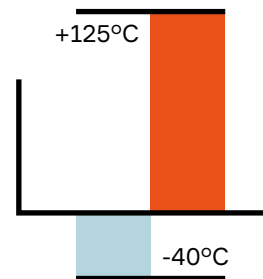

VIBRATION



CONNECTOR MATING FORCE



SEALING PROTECTION



About Aptiv

Aptiv is a global technology company that develops safer, greener and more connected solutions enabling the future of mobility.

Visit [aptiv.com](https://www.aptiv.com) →



Cavity count	Blade size (mm)	Gender	Dimensions L x W x H (mm)	Part number	Color
8	2.8 (6) + 8* (2)	F	56.8 x 50.8 x 45.9	10812007	Black
8	2.8 (6) + 8* (2)	F	56.8 x 50.8 x 45.9	13949302	Grey

* Please, consult Aptiv.



DIMENSION MEASUREMENT SAMPLE

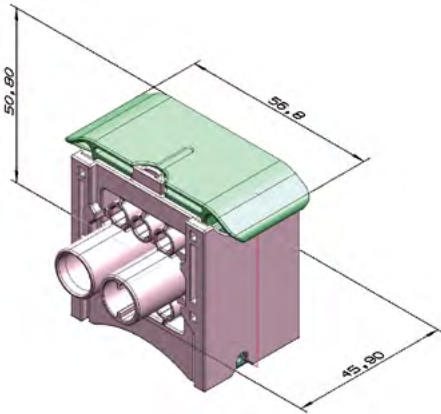

13949302



EXPLODED VIEW

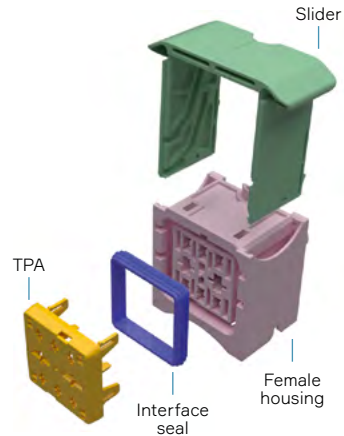

13949302



COMPATIBLE WITH



Part numbers, specifications, dimensions and performance data in this document are for general references only and are subject to change without notice. To verify product information, please contact an Aptiv representative.

CS-SP66-SICMA-En1120