

Powering LED Lighting for Horticulture

Lowering costs and improving results with the right power supply for your horticultural lighting

Introduction

The rapid growth in the use of LED lighting for horticulture and floriculture has been a driver in the power supply industry.

Lighting makers and growers are not typically specialists in power management, so experts at Advanced Energy's Artesyn Embedded Power have created this white paper to provide the information needed to define a power strategy that could have a significant impact on capital and operating expenses for greenhouses, and indoor and vertical farmers.

Application examples and financial models included in the paper provide you with the background you need to select the right power strategy for your application or installation.

Table of Contents

Types of Horticultural Lighting Applications	2
Powering Horticultural Lighting Power Architecture Examples	3
Using Artesyn Power Supplies	4
Application Example: Large warehouse farm requires 126.3 KW of LED luminaires	5
Innovative Modular and Scalable Power Solutions	6
	7

POWERING LED LIGHTING FOR HORTICULTURE

The use of LED technology in horticultural lighting systems is playing a fundamental role in cutting-edge farming and growing practices that are increasingly seen as a potential way of addressing production challenges for food, pharmaceutical ingredients, plants and flowers.

LED-based horticultural lighting is one of the largest and fastest growing markets.

Lighting for horticulture is quite distinct from other lighting applications. Light, in the wavelengths useful for horticulture, is called photo-synthetically active radiation (PAR) and falls within the 400-700nm range.

Photosynthetic Photon Flux, or PPF, measures the total amount of PAR photons generated by a luminaire. A higher PPF means the lighting system is more efficient at creating PAR.

As researchers continue to establish the impact of specific wavelengths of light on different plants and stages of growth, broad-spectrum sources such as high pressure sodium (HPS) lamps, popularly used in greenhouses, are being outperformed by LED lights due to their flexibility in producing different PAR wavelengths.

Other compelling benefits of LED lights for horticulture include:

- **Spectral output control:** LED lights offer greater control over the light output across different wavelengths, so growers can more closely match spectra to the needs of their plants, plus their luminosity can be adjusted to manage production depending on plant species and growth stage.
- **More precise targeting:** The availability of smaller LED lights improves control over where the light goes, increasing efficiency and reducing energy consumption.

- **Less radiated heat:** LED lights operate cooler than traditional HPS bulbs so can be placed closer to plants, resulting in more dense farms. This also lowers water consumption.
- **Life cycle savings:** LED luminaires typically have a longer lifetime, lower energy consumption and lower maintenance costs than traditional horticultural lighting options

The benefits outlined above combine to make LED lighting the ideal choice for supplemental lighting in greenhouses as well as vertical and indoor farms that depend on artificial light.

Market Drivers

- **Population growth and limited availability of agricultural land**
- **Ability to grow a steady supply of crops regardless of weather conditions**
- **Increased, higher-quality yield**
- **Government initiatives**
- **Legalization of cannabis for medicinal and recreational purposes**
- **Technical advances in LED technology**

Source: 2018 Horticulture Lighting Report by MarketsandMarkets Research

TYPES OF HORTICULTURAL LIGHTING

Top lighting – greenhouses

- **Illumination of the hall and plants from ceiling level**
- **Retrofitting old HPS, modifying spectral content of light**

- Challenges: light concentration on plants, uniformity and constant quality of light spectrum, high amount of power needed

Top lighting – vertical farming

- Illumination from top of the plants at close distance
- Challenges: uniform intensity and spectral distribution, plants shading each other, photosynthetic efficiency (PPF/W), heat

Intra-canopy

- Illumination on the side or in between the plants
- Possible with LEDs (HPS too hot)
- Challenges: uniform PPF, good color uniformity (if continuous/wide spectrum), spectrum fit to the rest of lighting, light direction

APPLICATIONS

Traditional greenhouses have been the primary adopters of horticultural LED lighting for many years, typically supplementing natural light. LED lighting supplementing natural light in large greenhouses or ‘growing warehouses’ improves control over the nutrient balance and growth cycle of a wide range of plants.

For example, Artesyn is working with a manufacturer of agricultural LED lights that is using the LCC600 600-watt series conduction cooled AC-DC power supplies for their market-leading full-spectrum LED grow light.

The company has been able to create an IP65 rated light for use in wet and humid conditions that saves over 40% on energy costs versus competing solutions and produces less heat than most of its competitors.



New types of farming are poised to lead the future growth of the industry, such as indoor and vertical farming. Whereas greenhouses mainly use LEDs in addition to the sun, indoor and vertical farming use LED fixtures as the primary or sole light source.

Indoor farming

Indoor farming covers a variety of growing techniques, including horizontal flood trays to vertical towers, warehouses to basements, and micro-greens to heirloom tomatoes. Indoor farms depend on artificial light and are mostly hydroponic, aeroponic, and/or aquaponic, which is one of the reasons why this type of facility uses less resources.

Even though it needs to be set up entirely with horticultural lighting, which increases the initial CAPEX investment, operational cost is relatively low thanks to reduced irrigation, chemical and labor expenses. Using LED-based grow lights brings down the cost even further.

Vertical farming

With vertical farms, shipping containers or similar structures are used to house shelves of plants, with lighting and nutrients supplied and carefully controlled to manage the growth of the crop. Advocates of this type of agriculture argue that this method of growing crops can be done closer

POWERING LED LIGHTING FOR HORTICULTURE

to consumers (reducing food miles), without pesticides or other chemicals thanks to the contained environment, and using less water than conventional outdoor agriculture.

One pioneering creator of vertical farming solutions has adopted Artesyn's iHP series configurable digital high power system to provide the DC power for their custom-engineered horticultural LED lights. These provide specific photon wavelengths and intensity, enabling the customer to create customized "light recipes" for each crop.



The iHP series provides up to 24 kW in 3 kW increments and can be configured for up to 8 outputs using a wide variety of plug-in modules that address a large range of voltages and currents. It provides the user with analog and digital control as either a programmable voltage or current source.

Using up to 99% less water, no pesticides or herbicides, reducing food miles by up to 93%, and having unrivalled control over the crops means that vertical farming may be the future for many communities around the world and off the planet.

POWERING HORTICULTURAL LIGHTING

A survey by the Lighting Research Center (LRC) found that the majority of growers did not know their monthly electrical costs for lighting. 64% of growers reported that they pay a flat energy rate or a combination rate (energy rate and demand charges) for their electricity. 20% of growers did not know how they were billed for electricity.

Source: The Lighting Research Center (LRC)

For individual luminaires and lower power applications (ranging from 300 W to 3000 W), the key criteria are size and weight for a given power rating. Heavier and larger power supplies require more substantial and therefore more expensive rigging, usually from the ceiling of the greenhouse.

With large farms, the use of individual luminaires is not efficient. The added complexity of individual control systems on each luminaire and the additional cabling required adds to the installation costs. Furthermore, the additional thermal management needed (air conditioning) as a result of the collective conversion/heat losses from the drivers adds to growers' energy costs.

Using a large centralized current source outside the environmentally controlled growth areas and distributing power directly to all the luminaires can help eliminate the need for individual drivers and the associated costs.

Another consideration for growers is Total Harmonic Distortion (THD).

Total harmonic distortion is a measurement of how much of the distortion of a voltage or current is due to harmonics in the signal. A lower THD typically means higher power factor, lower peak currents and higher efficiency - all of which are desirable in a power system and beneficial to the application.

Many of utility companies now use smart meters to measure THD and, depending on the level, will set billing rates associated to THD. Artesyn's iHP system provides a much lower THD than many integrated LED drivers.

Another benefit of the iHP centralized power source approach, as identified by one of Artesyn's customers, is that the same cabling that is used for HPS lights can be used for power LED luminaires using an iHP system. This can simplify and significantly speed up the installation time for new grow operations or the time to convert an existing facility.

Hydroponic, Aeroponic, Aquaponic

- **Hydroponics is defined as the cultivation of plants in water. No soil is used in hydroponic gardening, but in some cases a different medium is used as a place for the roots to grow and support the plant.**
- **Hydroponics is an umbrella term, which is used to cover a wide range of growing techniques and philosophies, including both aeroponics and aquaponics.**
- **Aquaponics is a specific branch of hydroponics that combines the use of fish, and plants.**
- **Aeroponics is another subgroup of hydroponics that involves a fine, nutrient-rich mist to feed and water plants.**

POWER ARCHITECTURE EXAMPLES USING ARTESYN POWER SUPPLIES

Conventional Power Distribution with Integrated Luminaire + Driver

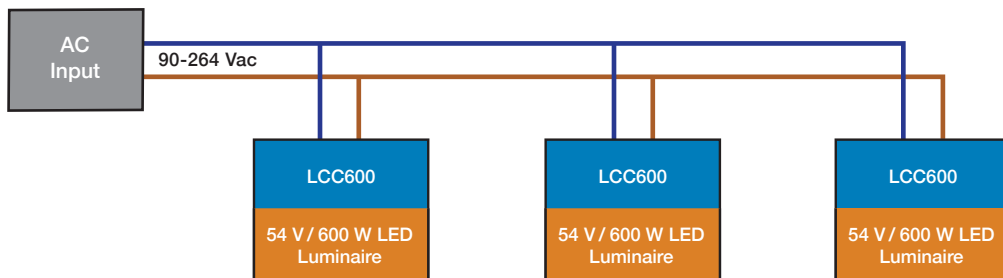

Example shown using Artesyn's LCC600 supply/driver integrated into a 600 W luminaire.

- Easily adaptable for retrofit (can utilize existing power/wiring infrastructure) and new installations
- Dimming Control: 0-10V or resistive Dimming (0-100% output current)
- Heat generated by both luminaire and driver/power supply needs to be considered in energy/cooling calculations

Centralized Power with Distributed Lighting using 54 V LED String in Serial Configuration



Artesyn iHP 12KW

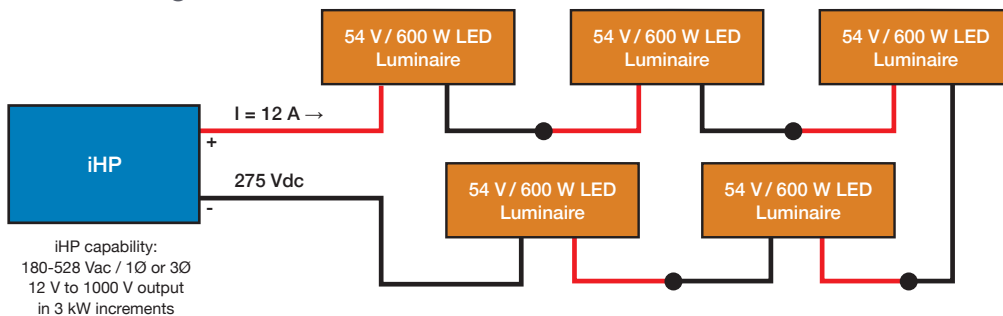

iHP example shown using one (1) 3 kW module set to 275 Vdc, 12 A constant current output.

- Centralized power source and the associated conversion/heat losses can be managed separately outside the environmentally controlled growth space, lowering cooling and energy cost
- Higher voltage distribution can help reduce total installation cost (e.g., reduced wire sizes)
- Faults in serial configuration can shut down all the luminaires connected in the same loop

Centralized Power with Distributed Lighting using 250 V LED String in Parallel Configuration

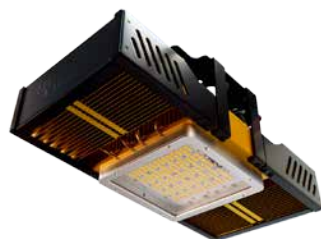

600W LED Luminaire

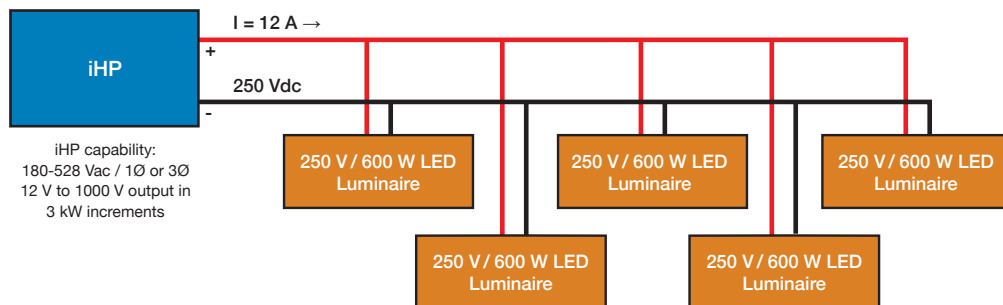

iHP example shown using one (1) 3 kW module set to 250 Vdc, 12 A constant current output.

- 347/600VAC 3-Phase input
Analog: 0-5V or 0-10V dimming Control (0-100% output current)
Digital: Cloud-Based Ethernet or LAN control
- Centralized power source and the associated conversion/heat losses can be managed separately outside the environmentally controlled growth space, lowering cooling and energy cost
- Higher voltage distribution can help reduce total installation cost (e.g., reduced wire sizes)
- Faults in parallel configuration will not shut down all luminaires connected on the same power rail

APPLICATION EXAMPLE: LARGE WAREHOUSE FARM REQUIRES 126.3 KW OF LED LUMINAIRES

SCENARIO 1: STANDARD DIRECT INTEGRATED LIGHTING

AC Hook-up Wiring	Integrated Power, Driver and Thermal Management	Annual A/C Cost Due to Power Dissipation	Relative Installation and First Year Cost
\$21,000	\$54,400	\$9,281	\$80,681
Hook up to 240 integrated lights	Cost of conversion, driver and thermals for 600 W (240 pcs)	Based on 8.8 KW power loss requiring 30,133.5 BTUs/ Hr cooling	

SCENARIO 2: DISTRIBUTED LIGHTING USING LED STRING CONFIGURATION IN 48 V CONFIGURATION

DC Hook-up Wiring	Remote Power Supply	A/C Cost Due to Power Dissipation	Relative Installation and First Year Cost
\$56,808	\$16,116	\$0	\$72,924
Installation requires 2 AWG to rack, 4 AWG to distribution point, 12 AWG to fixture	Cost of remote CC mode precision power supply (iHP) using 48 V configuration	All power dissipation is external to the installation	

SCENARIO 3: DISTRIBUTED LIGHTING USING LED STRING CONFIGURATION IN 250 V CONFIGURATION

DC Hook-up Wiring	Remote Power Supply	A/C Cost Due to Power Dissipation	Relative Installation and First Year Cost
\$12,108	\$16,116	\$0	\$28,254
Installation requires 2 AWG to rack, 10 AWG to distribution point, 16 AWG to fixture	Cost of remote CC mode precision power supply (iHP) using 200 V configuration	All power dissipation is external to the installation	

Notes:

- A/C cost calculation used: $\frac{(\text{Operating hours} \times \text{BTU per hour}) \times 0,293}{1000} = \text{kWh} \times \text{Electricity costs per kWh}$
- Hook-up wiring requirements are estimated and costs are relative based on low volume online prices

INNOVATIVE MODULAR AND SCALABLE POWER SOLUTIONS

By offering single conduction and IP rated solutions up to large distributed external systems, Artesyn can help scale power for various power distribution architectures in practically any installation.

LCC600 Series



*600 Watts
Total Power*

- Dimming Control: 0-10V or resistive dimming
- 600 watts from -40 °C to 85 °C baseplate operating temperature
- High efficiency design in a 4" x 9" x 1.57" compact IP65 enclosure under 2 kgs
- Fanless design uses conduction cooling for thermal management – can utilize the same luminaire heatsink for thermal heat transfer
- 90-264 Vac or 180-305 Vac operating input
- Digital control: Constant voltage (default) or constant current mode of operation; programmable constant current limits through I2C/PMBus®
- External voltage or resistance dimming capable
- Active share/parallel operation for higher power

LCM Series



*300 - 3000 Watts
Total Power*

- Fan-cooled alternative to the LCC600, saving typically 50% of cost
- Digital control – can be set to operate in constant voltage or constant current
- Easily operated in parallel for higher power
- Great for controlled environment applications
- Conformal coating

iHP Series



*Configurable Intelligent
High Power System*

- Can drive any LED luminaire
- Customized grow cycle lighting control by setting scheduler (using calendar)
- Dimming Control: 0-5V or 0-10V (output completely off to full max output current)
- Removes driver heat from grow area to save on HVAC costs
- High level of scalability – multiple racks per cabinet can scale up to megawatt levels (in 3 kW increments up to 12 kW in small rack or 24 kW in large rack)
- Highly flexible input (180-528 Vac, single or 3-phase) and outputs (12-1000 Vdc) allows high voltage distribution, saving copper wiring costs
- Intelligent current and voltage source control (local or via Internet) eliminates the need for individual luminaire drivers
- Digitally controlled loop compensation eliminates bothersome flickering throughout entire operating range
- Cloud-based GUI allows simple user customization of lighting profile dashboards



For international contact information,
visit advancedenergy.com

powersales@aei.com (Sales Support)
productsupport.ep@aei.com (Technical Support)
+1 888 412 7832

ABOUT ADVANCED ENERGY

Advanced Energy (AE) has devoted more than three decades to perfecting power for its global customers. We design and manufacture highly engineered, precision power conversion, measurement and control solutions for mission-critical applications and processes.

Our products enable customer innovation in complex applications for a wide range of industries including semiconductor equipment, industrial, manufacturing, telecommunications, data center computing, and medical. With deep applications know-how and responsive service and support across the globe, we build collaborative partnerships to meet rapid technological developments, propel growth for our customers, and innovate the future of power.

PRECISION | POWER | PERFORMANCE

Specifications are subject to change without notice. ©2020 Advanced Energy Industries, Inc. All rights reserved. Advanced Energy® and AE® are U.S. trademarks of Advanced Energy Industries, Inc.