

# POWER

## MP Series 400 - 1200 Watts

### Data Sheet

**Total Power:** 400 - 1200 W  
**Input Voltage:** 85 - 264 VAC  
**# of Outputs:** Up to 21

### SPECIAL FEATURES

- Current share on all outputs with ratings of 10 A or greater
- Remote sense on all outputs with ratings greater than 2 A
- Overload protection on all outputs
- Voltage adjustment on all outputs
- Margining on all single output modules
- Input OK signal and status indicator LED
- Global DC OK signal and status indicator LED
- Global and individual module inhibits/enable
- Two year warranty
- Forced air cooling, field replaceable fan
- Isolated 5 V bias voltage
- Power factor correction
- EN61000-3-2 harmonic distortion compliance
- CISPR 22, EN55022 Curve B conducted/ radiated EMI
- European CE Mark requirements
- Optional VME timing and system DC OK module
- Customer-provided air option
- Additional 200 W output @ high line (180-264 VAC)
- Low leakage option for medical applications
- EN61000 immunity standards
- Standard modification flexibility (consult factory)
  - Low noise fan
  - Fan fail signal
  - Module enable
  - Outputs down to 0.5V
- Field demonstrated MTBF: > 550,000 hours at full load, 220 Vac & 25 °C ambient conditions



### Electrical Specifications

Input	
Input range	85 - 264 Vac
Frequency	47 - 440 Hz
Inrush current	40 A peak max. (soft start)
Efficiency	70 - 80% typ. @ full case load
Power factor	0.99 typ. meets EN61000-3-2
Turn-on time	AC on 1.5 sec typ. Inhibit/enable 150 ms typ.
EMI filter standard	CISPR 22/EN55022 Level "B"
EMI filter (low leakage option)	CISPR 22/EN55022 Level "A"
Leakage current standard	2.0 mA max. @240 Vac
Leakage current (low leakage option)	300 µA max. @ 240 Vac
Radiated EMI	CISPR 22/EN55022 Level "B"
Holdover storage	20 ms minimum (independent of input Vac)
AC OK	> 5 ms early warning min. before outputs lose regulation Full cycle ride thru (50 Hz)
Harmonic distortion	Meets EN61000-3-2
Isolation	Meets EN60950
Efficiency	70 - 80% typ. @ full case load
Global Inhibit/Enable	TTL, Logic "1" and Logic "0"
Input fuse (internal)	MP4: 10 A; MP6: 15 A; MP8: 20 A; MP1: 20 A
Warranty	2 years

### SAFETY

- UL UL1950
- CSA CSA22.2 No. 234 Level 5
- IEC IEC950, Class 1
- VDE EN60950
- BABT Compliance to EN 60950, BS 7002
- CB Certificate and report
- CE Mark

## Electrical Specifications

Output	
Adjustment range	± 10% minimum all outputs
Margining	± 4 - 6% nominal <sup>1</sup>
Overall regulation	0.4% or 20mV max. (36 W modules 4% maximum)
Ripple	RMS: 0.1% or 10 mV, whichever is greater Pk-Pk: 1.0% or 50 mV, whichever is greater Bandwidth limited to 20 MHz
Dynamic response	< 2% or 100 mV, with 25% load step
Recovery time	To within 1% in < 300 µsec
Overcurrent protection**	Single output module & main output of dual output module 105-120% of rated output current. Aux output of dual output module 105 -140% of rated output current
Shortcircuit protection	Protected for continuous short-circuit Recovery auto upon removal of short
Overvoltage protection (measured at sense connection)	Single output module: 2 - 5.5 V 122 - 134%; 6 - 60 V 110 - 120% Dual output module: 2 - 6 V 122 - 134%; 8 - 28 V 110 - 120% Triple output module: No overvoltage protection provided. Recycle AC input voltage to reset OVP circuit
Reverse voltage protection	100% of rated output current

Output (cont.)	
Thermal protection	All outputs disabled when internal temp exceeds safe operating range. > 5 ms warning (AC OK signal) before shutdown
Remote sense	Up to 0.5 V total drop (not avbl on triple output module)
Single wire parallel	Current share to within 2% of total rated current <sup>2</sup>
DC OK	-2% to -8% of nominal for any monitored output <sup>2</sup>
Minimum load	Not required on single or triple output. 10% required on main of dual output <sup>3</sup>
Housekeeping bias voltage	5 Vdc @ 1.0 A max. present whenever AC input is applied
Module inhibit	TTL, isolated, singles and dual (both outputs) only
Switching frequency	250k Hz
Output/Output isolation	> 1 Megohm
VME signal option board	POR signal & quad external DC OK
Hold-up module (HUP)	1-slot module providing additional 34 mSec (60 mSec total); hold-up @ 600 W loading.
Field Demonstrated MTBF	> 550,000 hours at full load, 220 Vac and 25 °C ambient conditions

1. Single output modules only.
2. Single and main of dual output modules only
3. Contact factory for optional preload if required

## Environmental Specifications

<b>Operating temperature</b>	-20 °C to 70 °C for standard airflow, -20 °C to 40 °C for reverse airflow (cold start @ 0 °C) Derate each output from 100% down to 50% load from 50 °C to 70 °C for forward airflow
<b>Shock/Vibration</b>	Mil-Hdbk 810E
<b>Humidity</b>	95% non-condensing
<b>Storage temperature</b>	-40 °C to 85 °C
<b>Temperature co-efficient</b>	0.02% per °C
<b>Cooling</b>	Internal DC fan or customer provided air (option)

## Output Module Line-up

Module Type	Single	Single	Single	Dual	Triple
Output	1	1	1	2	3
Max output power	210 W	360 W	600 W	144 W 36 W	120 mV
Max output current	35 A	60 A	120 A	10 A	2 A
Volts	2 - 60 V	2 - 60 V	2 - 60 V	2 - 28 V	2 - 28 V
Standard voltage increments	25	25	25	19	18
Remote sense on outputs	Yes	Yes	Yes	Yes, both	No
Remote margin/V-Program	Yes	Yes	Yes	No	No
Module Inhibit (isolated)	Yes	Yes	Yes	-	-
Single wire active current share	Yes	Yes	Yes	Yes, main only	-
Overvoltage/overcurrent protection	Yes	Yes	Yes	Yes	Over current
Minimum load required	No	No	No	Yes (10%) main only	No
Slots occupied in any MP case	1	2	3	1	1

## Output Module Voltage/Current

Voltage	Voltage Code	Single Output Module Code			Dual Output**		Triple Output		
		1	2	3	V1	V2	V1	V2	V3
2 V	A	35 A	60 A	120 A	—	10 A	—	—	2 A
2.2 V	B	35 A	60 A	120 A	—	10 A	—	—	2 A
3 V	C	35 A	60 A	120 A	—	10 A	—	—	2 A
3.3 V	D	35 A	60 A	120 A	—	10 A	—	—	2 A
5 V	E	35 A	60 A	120 A	10 A	10 A	—	—	2 A
5.2 V	F	35 A	60 A	115 A	—	10 A	—	—	2 A
5.5 V	G	34 A	58 A	109 A	—	10 A	—	—	2 A
6.0 V	H	23 A	42 A	78 A	—	10 A	—	—	2 A
8.0 V	I	20 A	36 A	68 A	—	—	1 A	1 A	1 A
10 V	J	18 A	32 A	60 A	—	—	1 A	1 A	1 A
11 V	K	17 A	31 A	54.5 A	—	—	1 A	1 A	1 A
12 V	L	17 A	30 A	50 A	10 A	4 A	1 A	1 A	1 A
14 V	M	14 A	21 A	40.5 A	9 A	4 A	1 A	1 A	1 A
15 V	N	14 A	20 A	39 A	8 A	4 A	1 A	1 A	1 A
18 V	O	11 A	19 A	33.3 A	—	—	—	0.5 A	0.5 A
20 V	P	10.5 A	18 A	30 A	—	—	—	0.5 A	0.5 A
24 V	Q	8.5 A	15 A	23.5 A	4 A	2 A	—	0.5 A	0.5 A
28 V	R	6.7 A	12.8 A	21.4 A	3 A	2 A	—	0.5 A	0.5 A
30 V	S	6.5 A	12 A	20 A	—	—	—	—	—
33 V	T	6.2 A	10.9 A	18.2 A	—	—	—	—	—
36 V	U	5.8 A	10 A	16.6 A	—	—	—	—	—
42 V	V	4.2 A	7.5 A	12.5 A	—	—	—	—	—
48 V	W	4.0 A	7.5 A	12.5 A	—	—	—	—	—
54 V	X	3.7 A	6.0 A	11 A	—	—	—	—	—
60 V	Y	3.5 A	6.0 A	10 A	—	—	—	—	—
Non-std*	Z	Special Voltage - Consult Factory for specifications							
2.4 - 2.7 V		35 A	60 A	120 A	—	10 A	—	—	2 A
3.6 - 4.5 V		35 A	60 A	120 A	—	10 A	—	—	2 A
6.6 - 9.2 V		20 A	36 A	68 A	10 A	4 A	—	—	1 A
8.8 - 9.0 V		18 A	32 A	60 A	10 A	4 A	—	—	1 A

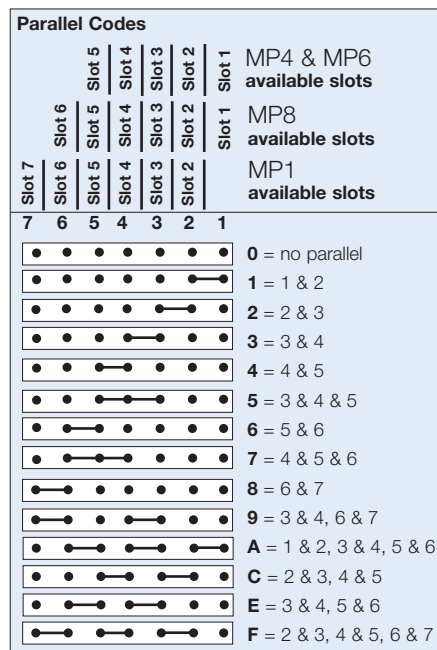

**Notes:**

- Omit digits that do not apply.
- Specify modules from lowest number of outputs to highest. (Single/Dual/Triple)
- If number of outputs are equal, specify modules from highest to lowest power increments. If power increments are equal, specify in descending alphabetical order (1A, B, C...).
- Always start with Slot 1.
- All MP model configurations created using this selection guide are standard MP products with standard availability and lead times.
- Optional VME/DCOK module must always be located in the last slot. Module designator is "VME".

## Ordering Information

Case Size	Module/Voltage/Option Codes	Add-on Modules	Case Option Codes	Hardware Code
<b>MP1</b>	First - Module Code Second - Voltage Code <b>- 3L - 2E - 1Q - 4LL</b>	<b>- HUP</b>	<b>- 00</b>	<b>-###</b>
<p><b>Case Size (mm)</b> 4 = 2.5" x 5" x 10"; 400 - 600 W, 5 Slots (63.5 x 127 x 254) 6 = 2.5" x 5" x 11"; 600- 800 W, 5 Slots (63.5 x 127 x 279.4) 8 = 2.5" x 7" x 10"; 800 - 1000 W, 6 Slots (63.5 x 177.8 x 254) 1 = 2.5" x 8" x 11"; 1000 - 1200 W, 7 Slots* (63.5 x 203.2 x 279.4)</p>	<p><b>Module Codes</b> Module/Voltage/Option Codes Module codes: (None) = 36 W triple O/P (1 slot) 1 = 210 W single O/P (1 slot) 2 = 360 W single O/P (2 slot) 3 = 600 W single O/P (3 slot) 4 = 144 W dual O/P (1 slot) 5 - 9 = future</p> <p><b>Voltage Codes:</b> See Output Module Voltage/Current table above</p>	<p>HUP = Hold up module VME = VME POR signal and isolated DC</p>	<p><b>Case Option Codes</b></p> <p>First digit 0 - 9, A - Z parallel code (See Parallel Codes table above)</p> <p>Second digit Standard Options 0 = No options 1 = Rear Air Exhaust 3 = Global enable 5 = Opt 1 + Opt 3 M = Low Leakage N = Low Leakage + Opt 1 P = Low Leakage + Opt 3 R = Low Leakage + Opt 5</p>	<p>Factory assigned for modifications</p>

Single

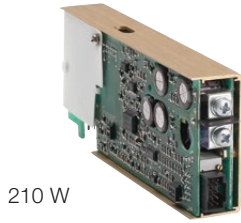

210 W



360 W

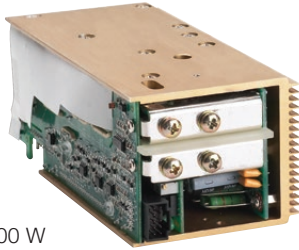

600 W

Dual

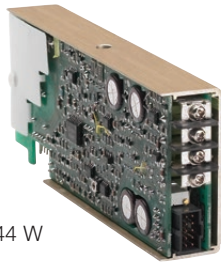

144 W

Triple



MP4 & MP6

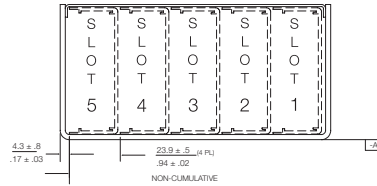

Input  
 85-264 Vac      180-264 Vac  
 MP4 = 2.5" x 5" x 10" 5 available slots      400 W max.      600 W max.  
 (63.5 x 127 x 254 mm)  
 MP6 = 2.5" x 5" x 11" 5 available slots      600 W max.      800 W max.  
 (63.5 x 127 x 279.4 mm)

MP8

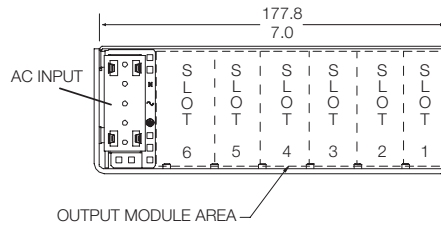

Input  
 85-264 Vac      180-264 Vac  
 MP8 = 2.5" x 7" x 10" 6 available slots      800 W max.      1000 W max.  
 (63.5 x 177.8 x 254 mm)

MP1

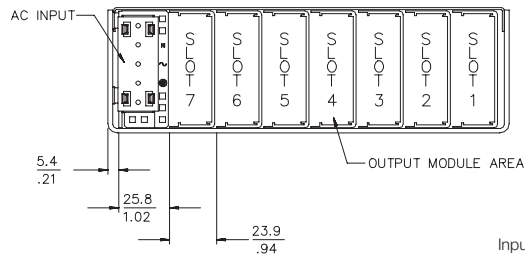

Input  
 85-264 Vac      180-264 Vac  
 MP1 = 2.5" x 8" x 11" 7 available slots      1000 W max.      1200 W max.  
 (63.5 x 203.2 x 279.4 mm)

Pin Connectors

Figure 1. Connector J1

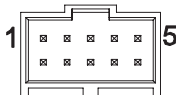

Mates with  
 Molex 90142-0010 Housing  
 90119-2110 Pin

PFC Input Connector	
J1 Control Connector	Standard for all cases
Pin No.	Function
J1-1	Input AC OK - "emitter"
J1-2	Input AC OK - "collector"
J1-3	Global DC OK - "emitter"
J1-4	Global DC OK - "collector"
J1-5	Spare
J1-6	Global inhibit/optional enable logic "0"
J1-7	Global inhibit/optional enable logic "1"
J1-8	Global inhibit/optional enable return
J1-9	SELV 5 V housekeeping
J1-10	SE:V 5 V housekeeping return

## Mechanical Drawings

### MP Modules

#### DC-DC Converter Output Modules

PFC Input Connector		
Pin No.	Function	
1	+ Remote Sense	single or dual o/p main
2	Remote Margin / V. Program	single o/p
3	Margin High	single o/p
4	- Remote Sense/Margin Low	single or dual o/p main
5	Spare	
6	Module, Isolated Inhibit	single or dual o/p
7	Module Inhibit Return	single or dual o/p
8	Current Share (SWP)	single or dual o/p main
9	+ Remote Sense V2	dual o/p, single is spare
10	- Remote Sense V2	dual o/p, single is spare

Figure 4. Connector J1



#### Single 210 Watt

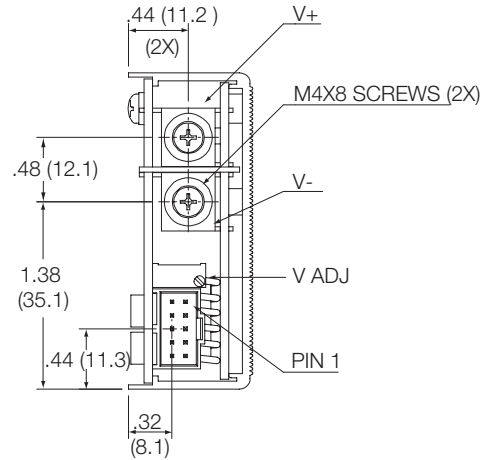

#### Single 600 Watt

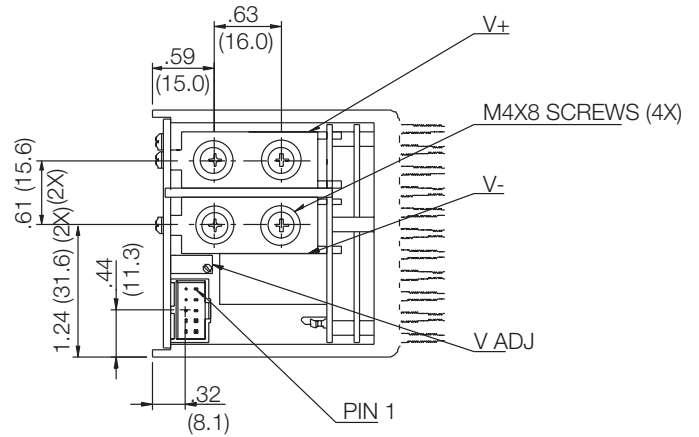

#### Single 360 Watt

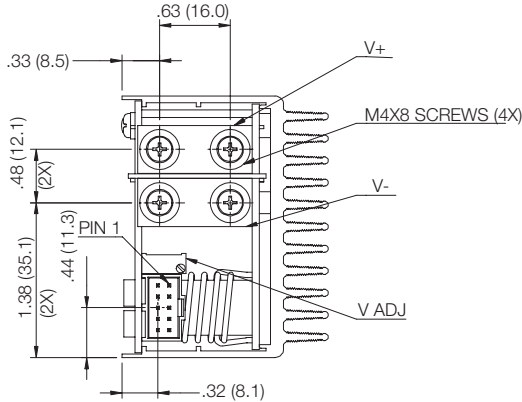

#### Dual 144 Watt

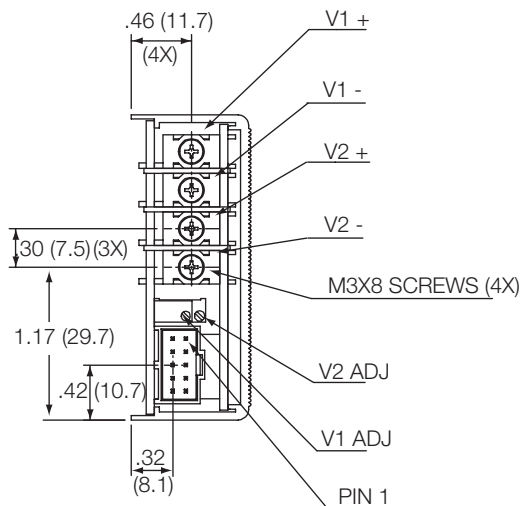

#### Triple 36 Watt

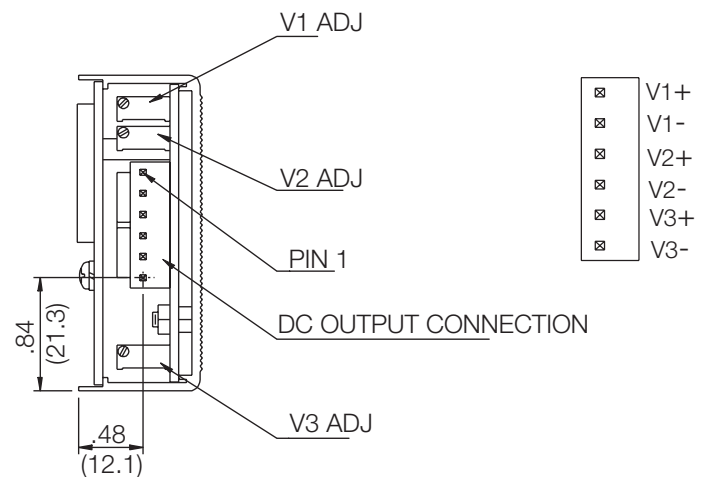

MP Series

**MP4 (400/600 Watts Max)**  
**MP6 (600/800 Watts Max)**

5-Inch Case Size: MP4: 2.5" x 5" x 10" (63.5 mm x 127mm x 254 mm)  
 5-Inch Case Size: MP6: 2.5" x 5" x 11" (63.5 mm x 127 mm x 279.4mm)  
 Weight: MP4 Case: 2.6 lbs. • MP6 Case: 3.2 lbs. • 36 W Triple: 0.5 lb. • 210 W Single: 0.6 lb.  
 • Single O/P: 0.22 lb. • Dual O/P: 0.16 lb. • Blank: 0.06 lb.

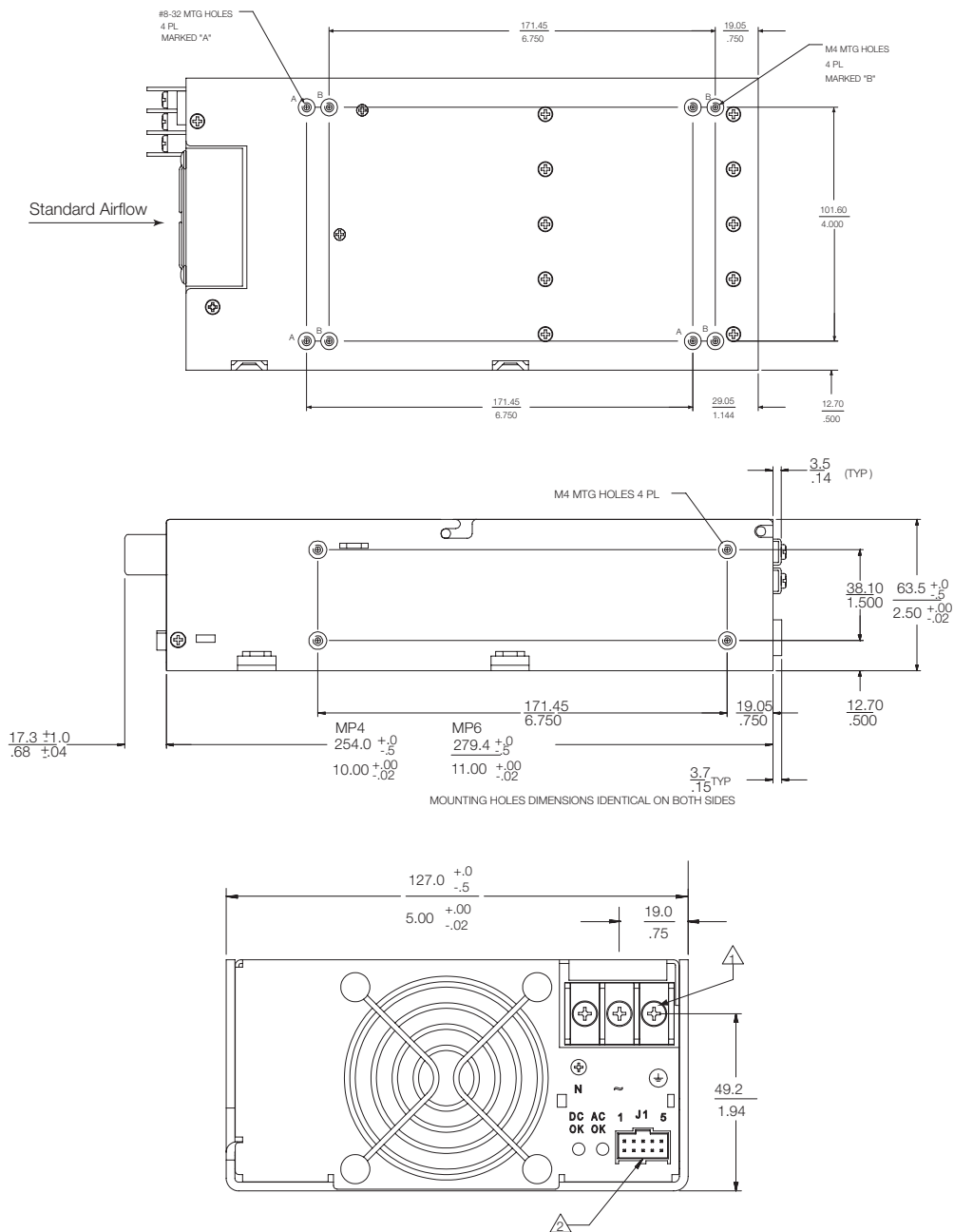

- Notes:**
1. Input: Barrier type. Three No. 6-32 B.H. screws (0.375" centers). Max torque: 6 in-lbs. (0.67 N-m).
  2. Control connectors: (J1 and J2) 10 position housing, gold plated contacts. Mates with Molex 90142-0010 housing with 90119-2110 crimp contacts (Molex C - Grid III Series). Connector kit includes mating connector and 10 pins, Astec part #70-841-004.
  3. Chassis material: aluminum with chemical film coating (conductive).
  4. All dimensions are in millimeters and inches, and are typical.
  5. Customer mounting -3 sides M4, bottom also includes 8-32 mounting holes. Max. penetration is 0.150" (3.8 mm). Max. torque: 5 in-lbs.
  6. Output module connections: All single O/P modules are M4 x 8 mm screws. Max. torque: 10 in-lbs.  
 Dual O/P module is M3 x 8 mm screws. Max. torque: 5 in-lbs.  
 Triple O/P module is .045" square pins on .156" centers. Mates with Moelx 09-50-8063 or equivalent.

MP Series

MP8 (800/1000 Watts Max)

7-Inch Case Size: MP8: 2.5" x 7" x 10" (63.5 mm x 177.8 mm x 254 mm)

Weight: MP8 Case: 4.1 lbs. • 36 W Triple: 0.5 lb. • 210 W Single: 0.6 lb. • 360 W Single: 1.0 lb.  
 • 600 W Single: 2.6 lbs. • 144 W Dual: 0.6 lb.

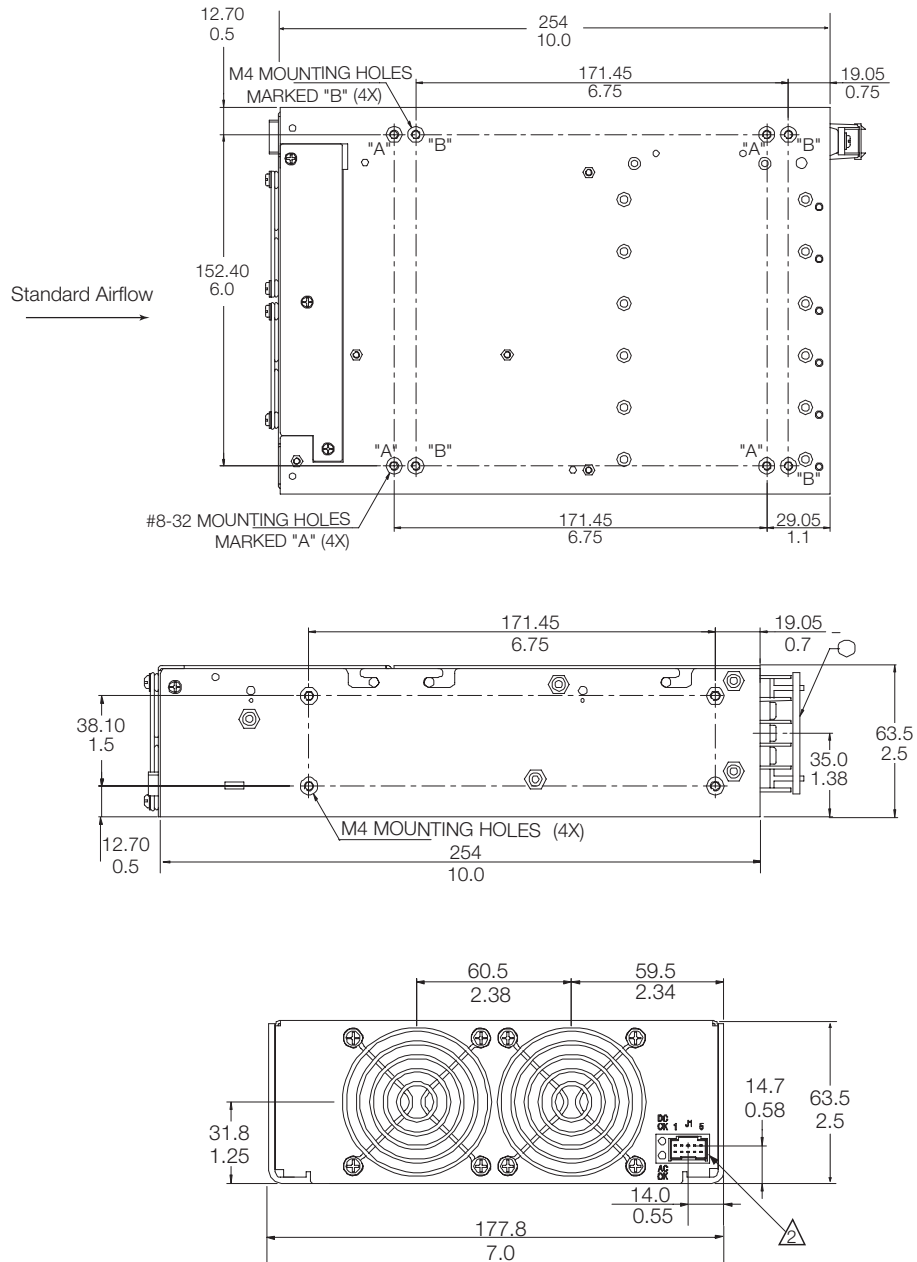

- Notes:**
1. Input: Barrier type. Three No. 6-32 B.H. screws (0.375" centers). Max torque: 6 in-lbs. (0.67 N-m).
  2. Control connectors: (J1 and J2) 10 position housing, gold plated contacts. Mates with Molex 90142-0010 housing with 90119-2110 crimp contacts (Molex C - Grid III Series). Connector kit includes mating connector and 10 pins, Astec part #70-841-004.
  3. Chassis material: aluminum with chemical film coating (conductive).
  4. All dimensions are in millimeters and inches, and are typical.
  5. Customer mounting -3 sides M4, bottom also includes 8-32 mounting holes. Max. penetration is 0.150" (3.8 mm). Max. torque: 5 in-lbs.
  6. Output module connections: All single O/P modules are M4 x 8 mm screws. Max. torque: 10 in-lbs.  
 Dual O/P module is M3 x 8 mm screws. Max. torque: 5 in-lbs.  
 Triple O/P Module is .045" square pins on .156 centers. Mates with Moelx 09-50-8063 or equivalent.

MP Series

MP1 (1000/1200 Watts Max)

8-Inch Case Size:

MP1: 2.5" x 8" x 11"  
(63.5 mm x 203.2 mm x 279.4 mm)

Weight:

- MP1 Case: 5.0 lbs.
- 36 W Triple: 0.5 lb.
- 210 W Single: 0.6 lb.
- 360 W Single: 1.0 lb.
- 600 W Single: 2.0 lbs.
- 144 W Dual: 0.6 lb.

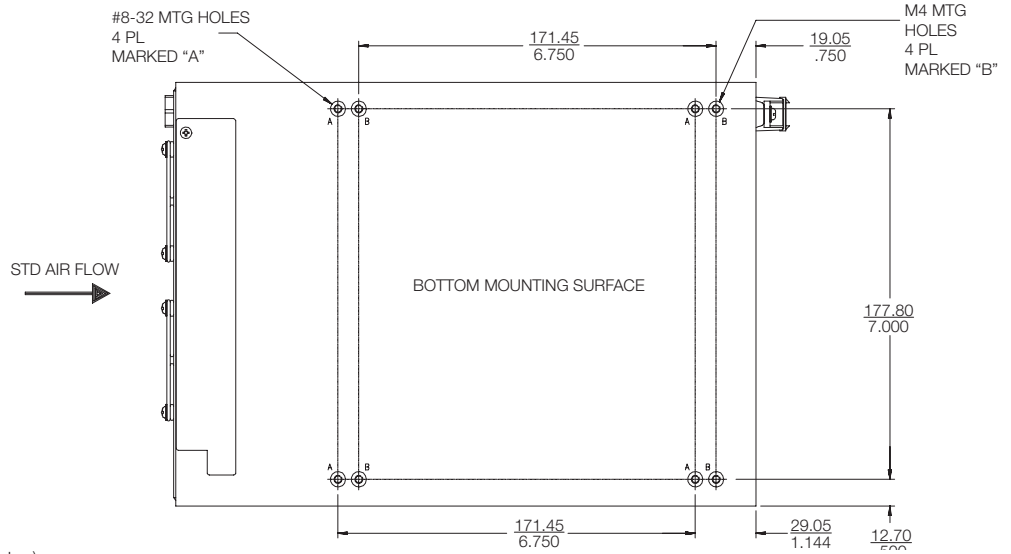
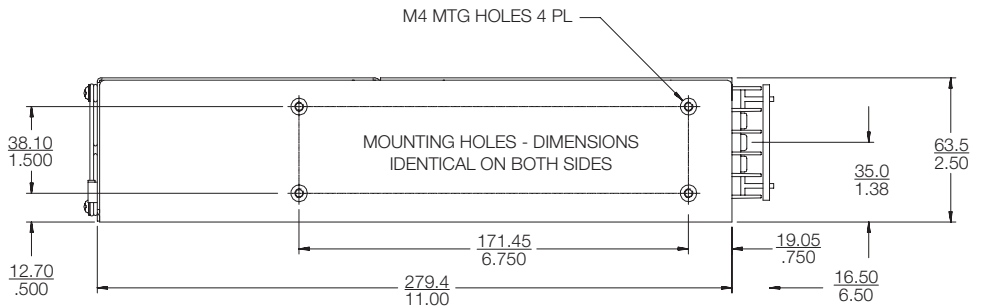

Notes:

1. Input: Barrier type. Three No. 6-32 B.H. screws (0.375" centers). Max torque: 6 in-lbs (0.67 N-m).
2. Control connectors: (J1 and J2) 10 position housing, gold plated contacts. Mates with Molex 90142-0010 housing with 90119-2110 crimp contacts (Molex C - Grid III Series). Connector kit includes mating connector and 10 pins, Astec part #70-841-004.
3. Chassis material: aluminum with chemical film coating (conductive).
4. All dimensions are in millimeters and inches, and are typical.
5. Customer mounting -3 sides M4, bottom also includes 8-32 mounting holes. Max. penetration is 0.150" (3.8 mm). Max. torque: 5 in-lbs.
6. Output module connections: All single O/P modules are M4 x 8 mm screws. Max. torque: 10 in-lbs. Dual O/P module is M3 x 8 mm screws. Max. torque: 5 in-lbs. Triple O/P module is .045" square pins on .156 centers. Mates with Molex 09-50-8063 or equivalent.

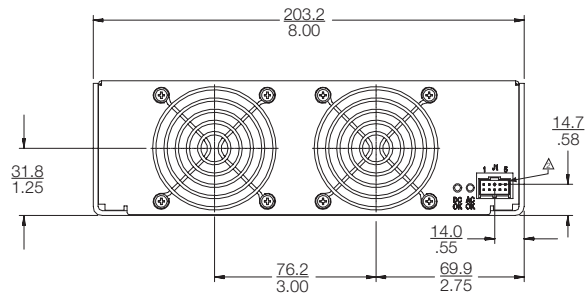

WORLDWIDE OFFICES

Americas

2900 S.Diablo Way  
Tempe, AZ 85282  
USA  
+1 888 412 7832

Europe (UK)

Waterfront Business Park  
Merry Hill, Dudley  
West Midlands, DY5 1LX  
United Kingdom  
+44 (0) 1384 842 211

Asia (HK)

14/F, Lu Plaza  
2 Wing Yip Street  
Kwun Tong, Kowloon  
Hong Kong  
+852 2176 3333



www.artesyn.com

Artesyn Embedded Technologies, Artesyn and the Artesyn Embedded Technologies logo are trademarks and service marks of Artesyn Embedded Technologies, Inc. All other names and logos referred to are trade names, trademarks, or registered trademarks of their respective owners. © 2016 Artesyn Embedded Technologies, Inc. All rights reserved. For full legal terms and conditions, please visit www.artesyn.com/legal.

For more information: [www.artesyn.com/power](http://www.artesyn.com/power)  
For support: [productsupport.ep@artesyn.com](mailto:productsupport.ep@artesyn.com)