



## Features

- EB welded metal strip
- Very high power
- Excellent long term stability
- Low resistance, low TCR
- Low thermal EMF
- RoHS compliant\* and halogen free\*\*
- AEC-Q200 compliant

## Applications

- Current sensing
- Voltage division
- Battery management systems
- Power modules
- Frequency converters
- Industrial

# Model CSS2H-2512 Series Current Sense Resistor

### Electrical Characteristics

Characteristic	Model CSS2H-2512 Series	
Resistance Range / Power Rating @70 °C <sup>1</sup> / Power Rating @130 °C <sup>1</sup>	CSS2H-2512C-000 <sup>3</sup>	< 0.1 mΩ / 100 A
	CSS2H-2512R-L300x	0.3 mΩ / 6 W / 3 W
	CSS2H-2512R-L500x	0.5 mΩ / 6 W / 3 W
	CSS2H-2512R-1L00x	1.0 mΩ / 5 W / 3 W
	CSS2H-2512K-1L80x	1.8 mΩ / 5 W / 3 W
	CSS2H-2512K-2L00x	2.0 mΩ / 5 W / 3 W
	CSS2H-2512K-2L30x	2.3 mΩ / 5 W / 3 W
	CSS2H-2512K-3L00x	3.0 mΩ / 4 W / 2 W
	CSS2H-2512K-3L50x	3.5 mΩ / 4 W / 2 W
	CSS2H-2512K-4L00x	4.0 mΩ / 3 W / 2 W
CSS2H-2512K-5L00x	5.0 mΩ / 2.5 W / 1.5 W	
Operating Temperature Range	-55 to +170 °C	
TCR - Resistive Alloy <sup>2</sup>	±50 PPM/°C (20~60 °C)	
Temperature Coefficient including Copper Terminals	CSS2H-2512R-L300x	±150 PPM/°C
	CSS2H-2512R-L500x	±100 PPM/°C
	CSS2H-2512R-1L00x	±75 PPM/°C
	CSS2H-2512K-1L80x	±75 PPM/°C
	CSS2H-2512K-2L00x	±75 PPM/°C
	CSS2H-2512K-2L30x	±75 PPM/°C
	CSS2H-2512K-3L00x	±75 PPM/°C
	CSS2H-2512K-3L50x	±75 PPM/°C
	CSS2H-2512K-4L00x	±75 PPM/°C
	CSS2H-2512K-5L00x	±75 PPM/°C
Inductance	< 2 nH	
Resistance Tolerance	±1 %, ±5 %	

- <sup>1</sup> Terminal temperature  
<sup>2</sup> For full TCR range, refer to TCR curve  
<sup>3</sup> Tinned copper

### How to Order

**CSS 2H - 2512 R - L500 J**

Model

No. of Terminals & Style

Size

Material Type   
(See Part Number Table)

Resistance Code (milliohms)   
"L" represents decimal point  
(examples: L500 = .500 milliohms;  
1L00 = 1.00 milliohms)

Resistance Tolerance   
F = ±1 %  
J = ±5 %

Packaging size   
Blank = Standard 13 " reel  
E = Mini 7 " reel

### Typical Part Marking

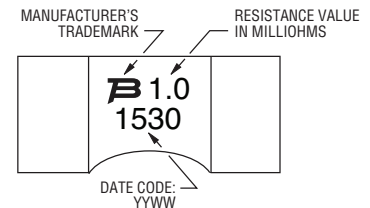

### Environmental Characteristics

Characteristic	Test Condition	ΔR Max.
Thermal Shock	-55 to +150 °C / 2000 Cycles	0.50 %
Short Time Overload	5 Times Rated Power for 5 Second Duration	0.50 %
Resistance to Soldering Heat	+260 °C / 10 Seconds	0.50 %
High Temperature Exposure	+170 °C / 2000 Hours	1.00 %
Low Temperature Storage	-65 °C / 24 Hours	0.10 %
Biased Humidity Test	+85 °C, 85 %R.H., 1000 Hours	0.50 %
Moisture Resistance	10 Days with Cold Shock, No Load	0.20 %
Mechanical Shock	100 g, 6 ms half sine	0.20 %
Vibration, High Frequency	20 g, 10-2000 Hz	0.20 %
Load Life	2000 Hours, Max. Load, Terminal Temperature 130 °C	1.00 %
Solderability	J-STD-002	95 % Coverage Min.
ESD	AEC-Q200-002, 25 kV	0.25 %
Board Flex	60 Sec. Min. Holding Time	0.25 %
Moisture Sensitivity Level		Level 1
ESD Classification (HBM)		6

\* RoHS Directive 2002/95/EC Jan. 27, 2003 including annex and RoHS Recast 2011/65/EU June 8, 2011.

\*\*Bourns considers a product to be "halogen free" if (a) the Bromine (Br) content is 900 ppm or less; (b) the Chlorine (Cl) content is 900 ppm or less; and (c) the total Bromine (Br) and Chlorine (Cl) content is 1500 ppm or less.

Specifications are subject to change without notice.

The device characteristics and parameters in this data sheet can and do vary in different applications and actual device performance may vary over time.

Users should verify actual device performance in their specific applications.

# Model CSS2H-2512 Series Current Sense Resistor

**BOURNS®**

## Product Dimensions

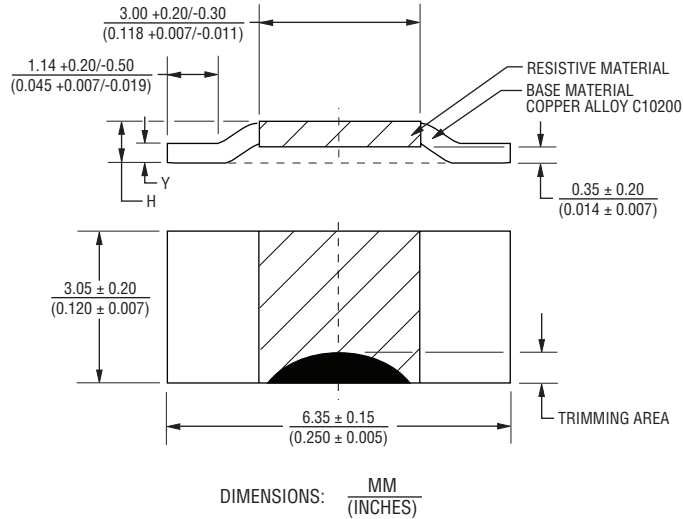

Part Number	Dimension H	Dimension Y
CSS2H-2512C-000	$0.77 \pm 0.10$ (0.030 ± 0.004)	$0.42 \pm 0.10$ (0.016 ± 0.004)
CSS2H-2512R-L300x	$1.65 \pm 0.10$ (0.065 ± 0.004)	$1.20 \pm 0.10$ (0.047 ± 0.004)
CSS2H-2512R-L500x	$1.13 \pm 0.10$ (0.044 ± 0.004)	$0.84 \pm 0.10$ (0.033 ± 0.004)
CSS2H-2512R-1L00x	$0.77 \pm 0.10$ (0.030 ± 0.004)	$0.42 \pm 0.10$ (0.016 ± 0.004)
CSS2H-2512K-1L80x	$1.06 \pm 0.10$ (0.042 ± 0.004)	$0.55 \pm 0.10$ (0.022 ± 0.004)
CSS2H-2512K-2L00x	$0.80 \pm 0.10$ (0.031 ± 0.004)	$0.42 \pm 0.10$ (0.016 ± 0.004)
CSS2H-2512K-2L30x		
CSS2H-2512K-3L00x	$0.77 \pm 0.10$ (0.030 ± 0.004)	$0.42 \pm 0.10$ (0.016 ± 0.004)
CSS2H-2512K-3L50x		
CSS2H-2512K-4L00x		
CSS2H-2512K-5L00x		

## Recommended Pad Layout

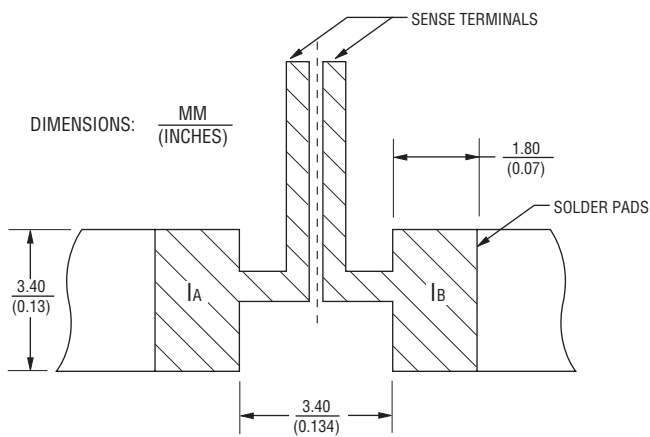

## Recommended Measurements

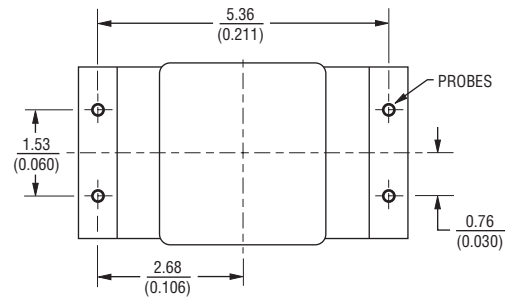

Specifications are subject to change without notice.  
 The device characteristics and parameters in this data sheet can and do vary in different applications and actual device performance may vary over time.  
 Users should verify actual device performance in their specific applications.

# Model CSS2H-2512 Series Current Sense Resistor



## TCR Curves

K-Type Resistive Material

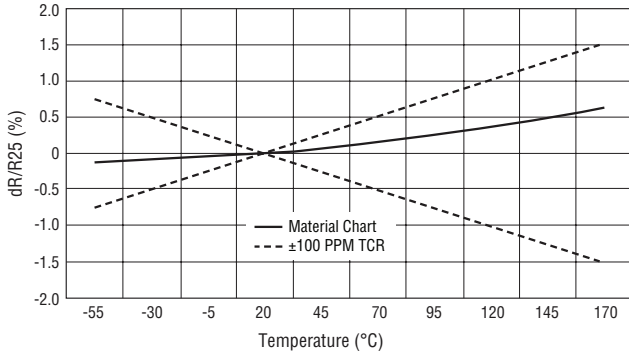

R-Type Resistive Material

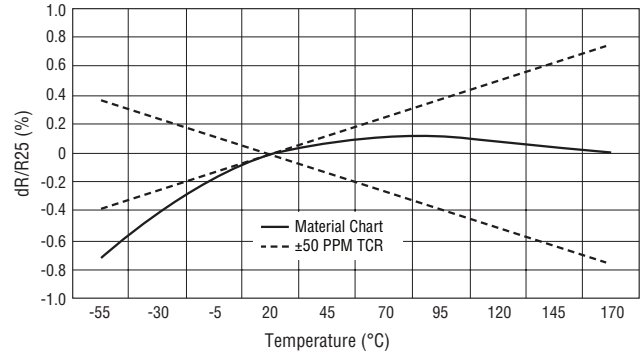

K-Type Resistive Material

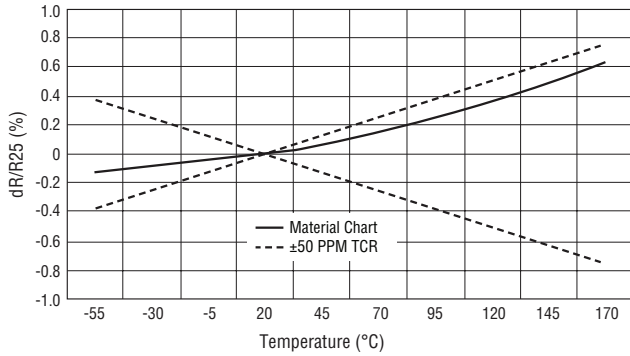

R-Type Resistive Material

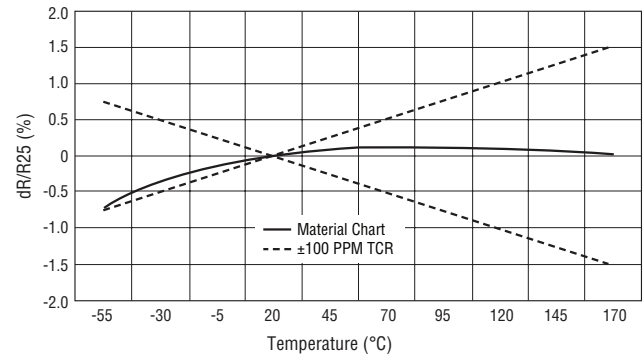

## Power Derating Curves

@ 70 °C

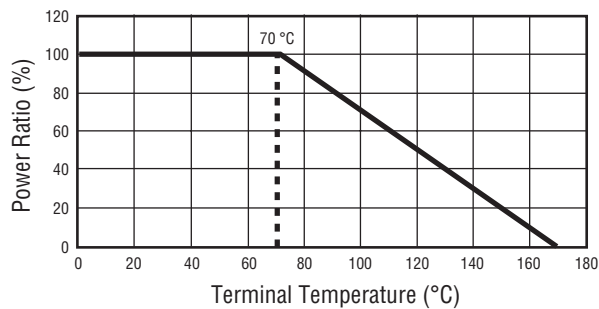

@ 130 °C

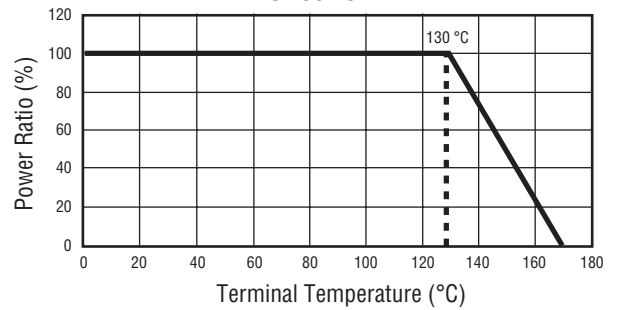

Specifications are subject to change without notice.  
 The device characteristics and parameters in this data sheet can and do vary in different applications and actual device performance may vary over time.  
 Users should verify actual device performance in their specific applications.

# Model CSS2H-2512 Series Current Sense Resistor

**BOURNS®**

## Maximum Pulse Power

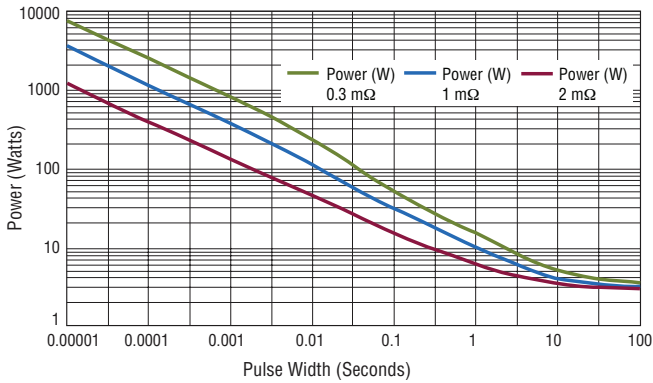

## Maximum Pulse Energy

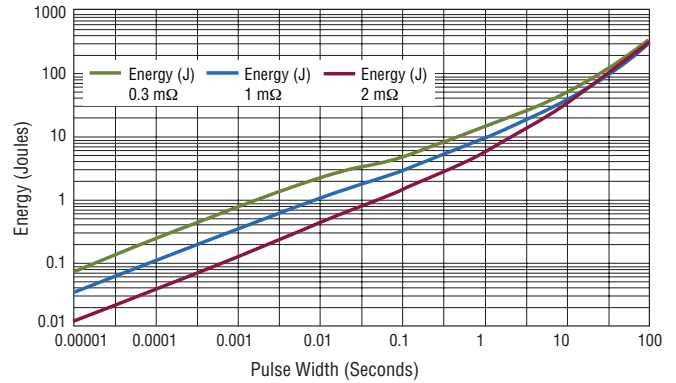

## Packaging Specifications

Components packaged per EIA-481.

Standard Reel Size: 13 inches  
 Tape Width: 12 mm  
 Quantity: 3,000 pcs. per reel

Mini-Reel Size: 7 inches  
 Tape Width: 12 mm  
 Quantity: 1000 pcs. per reel

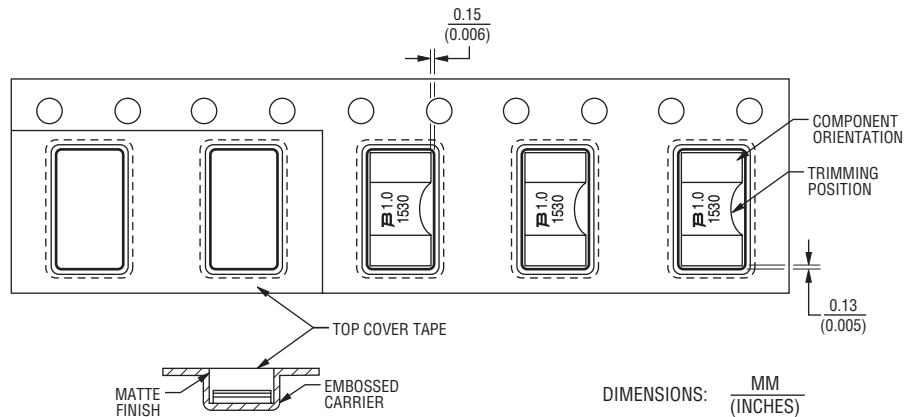

**BOURNS®**

Asia-Pacific: Tel: +886-2 2562-4117 • Email: asiacus@bourns.com

EMEA: Tel: +36 88 520 390 • Email: eurocus@bourns.com

The Americas: Tel: +1-951 781-5500 • Email: americus@bourns.com

[www.bourns.com](http://www.bourns.com)

REV. 01/18

Specifications are subject to change without notice.

The device characteristics and parameters in this data sheet can and do vary in different applications and actual device performance may vary over time.

Users should verify actual device performance in their specific applications.



## Features

- EB welded metal strip
- Very high power
- Excellent long term stability
- Low resistance, low TCR
- Low thermal EMF
- RoHS compliant\* and halogen free\*\*
- AEC-Q200 compliant

## Applications

- Current sensing
- Voltage division
- Battery management systems
- Power modules
- Frequency converters
- Industrial

## Model CSS2H-3920 Series Current Sense Resistor

### Electrical Characteristics

Characteristic	Model CSS2H-3920 Series	
Resistance Range / Power Rating @70 °C <sup>1</sup> / Power Rating @130 °C <sup>1</sup>	CSS2H-3920C-000 <sup>3</sup>	< 0.2 mΩ / 160 A
	CSS2H-3920R-L200x	0.2 mΩ / 12 W / 5 W
	CSS2H-3920R-L300x	0.3 mΩ / 10 W / 5 W
	CSS2H-3920R-L500x	0.5 mΩ / 9 W / 5 W
	CSS2H-3920R-L700x	0.7 mΩ / 8 W / 5 W
	CSS2H-3920R-1L00x	1.0 mΩ / 8 W / 5 W
	CSS2H-3920K-2L00x	2.0 mΩ / 6 W / 4 W
	CSS2H-3920K-2L50x	2.5 mΩ / 5 W / 3.5 W
	CSS2H-3920K-3L00x	3.0 mΩ / 5 W / 3 W
	CSS2H-3920K-4L00x	4.0 mΩ / 4 W / 2.5 W
CSS2H-3920K-5L00x	5.0 mΩ / 3 W / 2 W	
Operating Temperature Range	-55 to +170 °C	
TCR - Resistive Alloy <sup>2</sup>	±50 PPM/°C (20~60 °C)	
Temperature Coefficient including Copper Terminals	CSS2H-3920R-L200x	±100 PPM/°C
	CSS2H-3920R-L300x	
	CSS2H-3920R-L500x	
	CSS2H-3920R-L700x	
	CSS2H-3920R-1L00x	
	CSS2H-3920K-2L00x	±75 PPM/°C
	CSS2H-3920K-2L50x	
	CSS2H-3920K-3L00x	
	CSS2H-3920K-4L00x	
	CSS2H-3920K-5L00x	
Inductance	< 3 nH	
Resistance Tolerance	±1 %, ±5 %	

- <sup>1</sup> Terminal temperature  
<sup>2</sup> For full TCR range, refer to TCR curve  
<sup>3</sup> Tinned copper

### How to Order

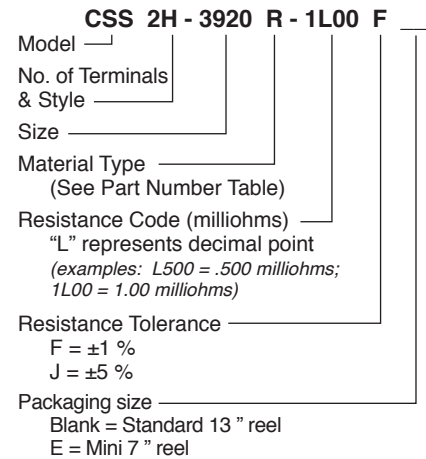

### Typical Part Marking

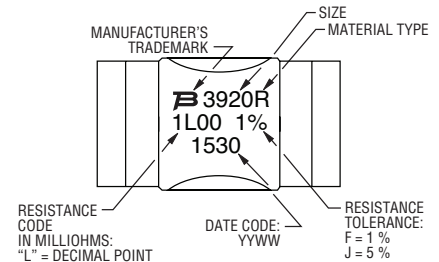

### Environmental Characteristics

Characteristic	Test Condition	ΔR Max.
Thermal Shock	-55 to +150 °C / 2000 Cycles	0.50 %
Short Time Overload	5 Times Rated Power for 5 Second Duration	0.50 %
Resistance to Soldering Heat	+260 °C / 10 Seconds	0.50 %
High Temperature Exposure	+170 °C / 2000 Hours	1.00 %
Low Temperature Storage	-65 °C / 24 Hours	0.10 %
Biased Humidity Test	+85 °C, 85 %R.H., 1000 Hours	0.50 %
Moisture Resistance	10 Days with Cold Shock, No Load	0.20 %
Mechanical Shock	100 g, 6 ms half sine	0.20 %
Vibration, High Frequency	20 g, 10-2000 Hz	0.20 %
Load Life	2000 Hours, Max. Load, Terminal Temperature 130 °C	1.00 %
Solderability	J-STD-002	95 % Coverage Min.
ESD	AEC-Q200-002, 25 kV	0.25 %
Board Flex	60 Sec. Min. Holding Time	0.25 %
Moisture Sensitivity Level		Level 1
ESD Classification (HBM)		6

\* RoHS Directive 2002/95/EC Jan. 27, 2003 including annex and RoHS Recast 2011/65/EU June 8, 2011.

\*\*Bourns considers a product to be "halogen free" if (a) the Bromine (Br) content is 900 ppm or less; (b) the Chlorine (Cl) content is 900 ppm or less; and (c) the total Bromine (Br) and Chlorine (Cl) content is 1500 ppm or less.

Specifications are subject to change without notice.

The device characteristics and parameters in this data sheet can and do vary in different applications and actual device performance may vary over time. Users should verify actual device performance in their specific applications.

# Model CSS2H-3920 Series Current Sense Resistor

**BOURNS®**

## Product Dimensions

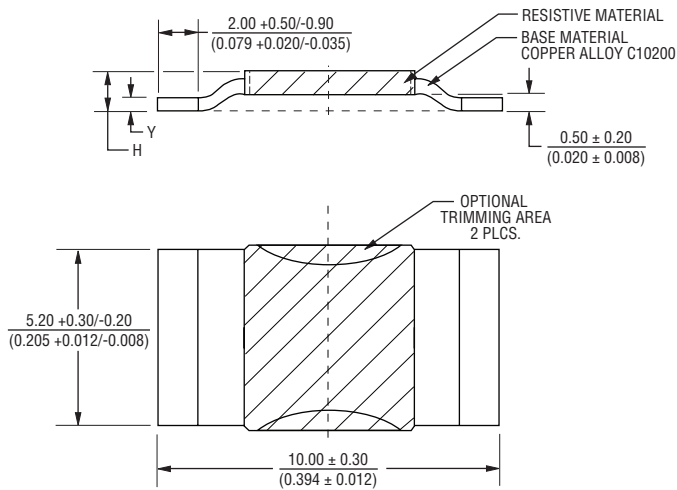

DIMENSIONS:  $\frac{\text{MM}}{\text{(INCHES)}}$

TOLERANCES:  $\frac{\pm 0.25}{(\pm 0.10)}$

Part Number	Dimension H	Dimension Y
CSS2H-3920C-000	$\frac{0.92 \pm 0.10}{(0.036 \pm 0.004)}$	$\frac{0.42 \pm 0.10}{(0.016 \pm 0.004)}$
CSS2H-3920R-L200x	$\frac{2.50 \pm 0.10}{(0.098 \pm 0.004)}$	$\frac{1.20 \pm 0.10}{(0.047 \pm 0.004)}$
CSS2H-3920R-L300x	$\frac{1.80 \pm 0.10}{(0.071 \pm 0.004)}$	$\frac{1.00 \pm 0.10}{(0.039 \pm 0.004)}$
CSS2H-3920R-L500x	$\frac{1.27 \pm 0.10}{(0.050 \pm 0.004)}$	$\frac{0.55 \pm 0.10}{(0.022 \pm 0.004)}$
CSS2H-3920R-L700x	$\frac{1.02 \pm 0.10}{(0.040 \pm 0.004)}$	$\frac{0.42 \pm 0.10}{(0.016 \pm 0.004)}$
CSS2H-3920R-1L00x	$\frac{0.92 \pm 0.10}{(0.036 \pm 0.004)}$	
CSS2H-3920K-2L00x	$\frac{1.18 \pm 0.10}{(0.046 \pm 0.004)}$	
CSS2H-3920K-2L50x	$\frac{1.04 \pm 0.10}{(0.041 \pm 0.004)}$	
CSS2H-3920K-3L00x	$\frac{0.96 \pm 0.10}{(0.038 \pm 0.004)}$	
CSS2H-3920K-4L00x	$\frac{0.92 \pm 0.10}{(0.036 \pm 0.004)}$	
CSS2H-3920K-5L00x	$\frac{0.92 \pm 0.10}{(0.036 \pm 0.004)}$	

## Recommended Pad Layout

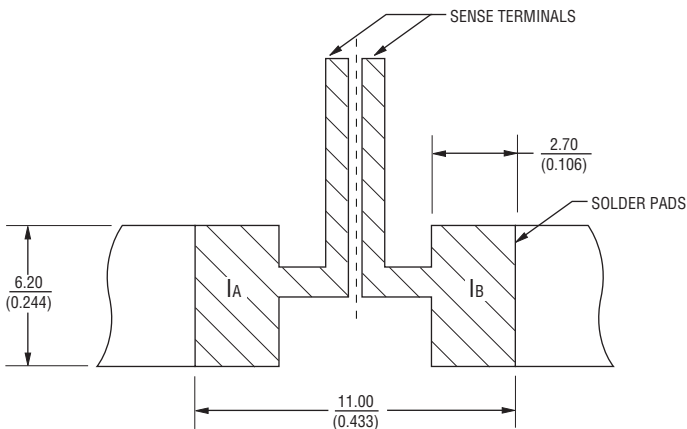

## Recommended Measurements

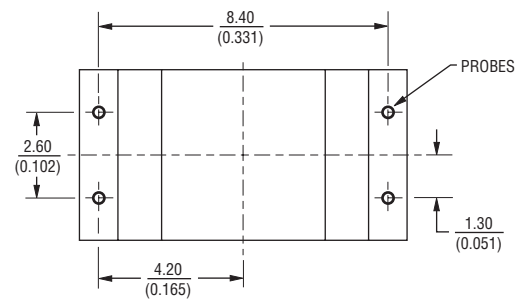

Specifications are subject to change without notice.

The device characteristics and parameters in this data sheet can and do vary in different applications and actual device performance may vary over time. Users should verify actual device performance in their specific applications.

# Model CSS2H-3920 Series Current Sense Resistor



## TCR Curves

K-Type Resistive Material

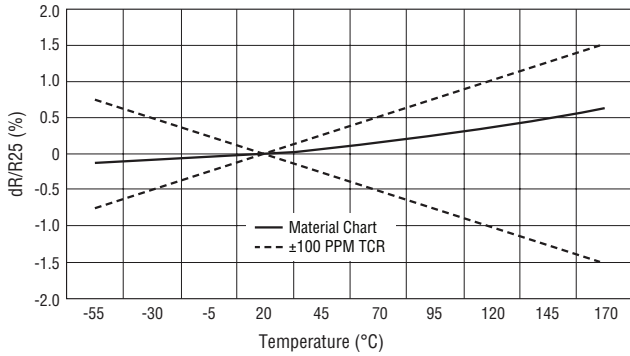

R-Type Resistive Material

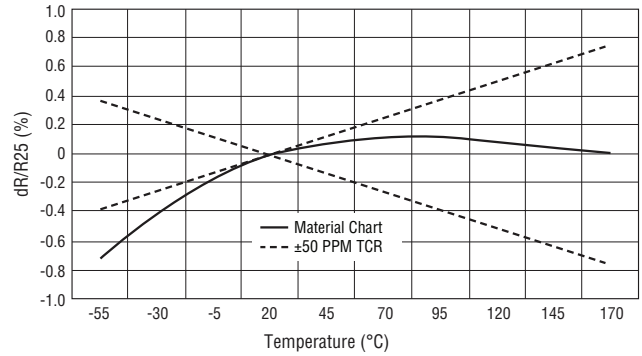

K-Type Resistive Material

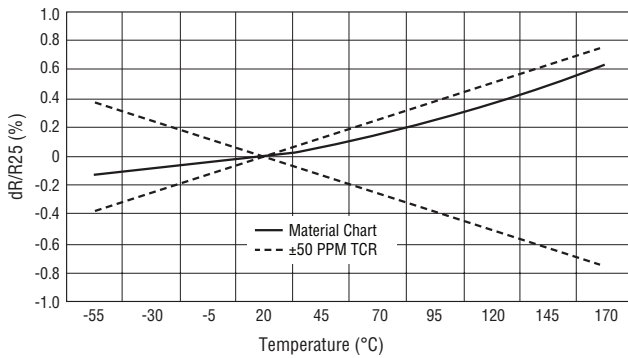

R-Type Resistive Material

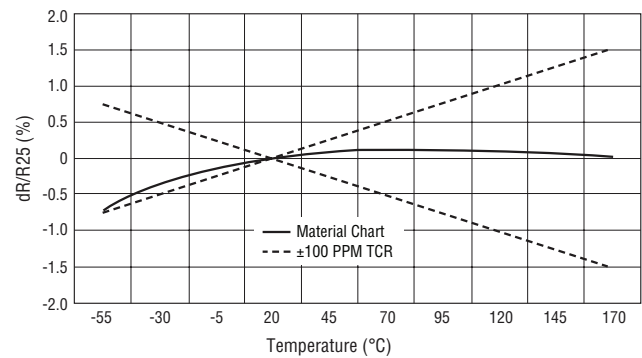

## Power Derating Curves

@70 °C

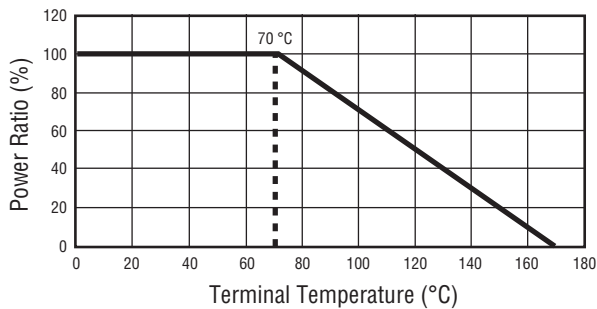

@130 °C

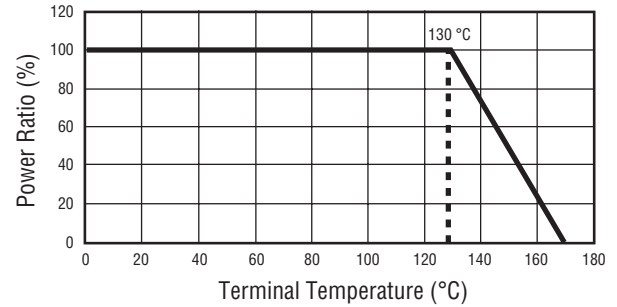

Specifications are subject to change without notice.

The device characteristics and parameters in this data sheet can and do vary in different applications and actual device performance may vary over time. Users should verify actual device performance in their specific applications.

# Model CSS2H-3920 Series Current Sense Resistor

**BOURNS®**

## Maximum Pulse Power

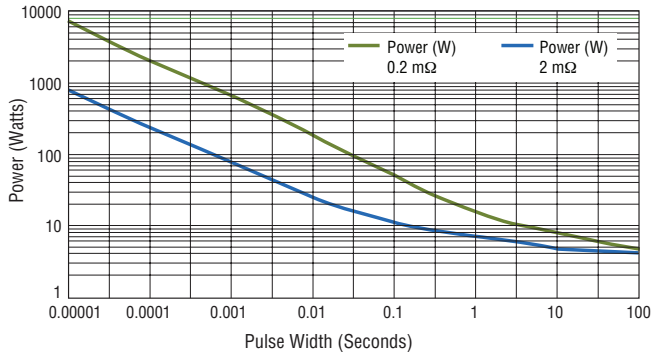

## Maximum Pulse Energy

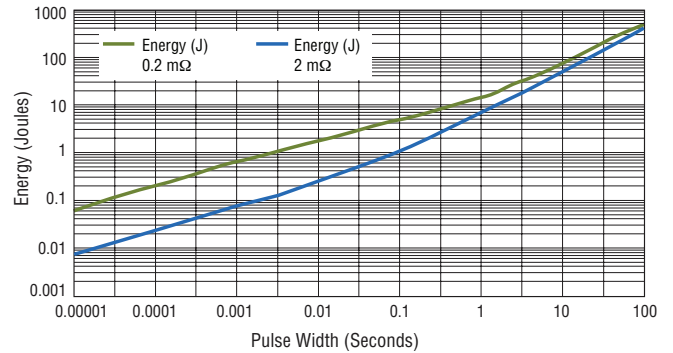

## Packaging Specifications

Components packaged on plastic tape & reel per EIA-481.

- Standard Reel Size: 13 inches
- Tape Width: 16 mm
- Quantity: 3,000 pcs. per reel
- Mini-Reel Size: 7 inches
- Tape Width: 16 mm
- Quantity: 1000 pcs. per reel

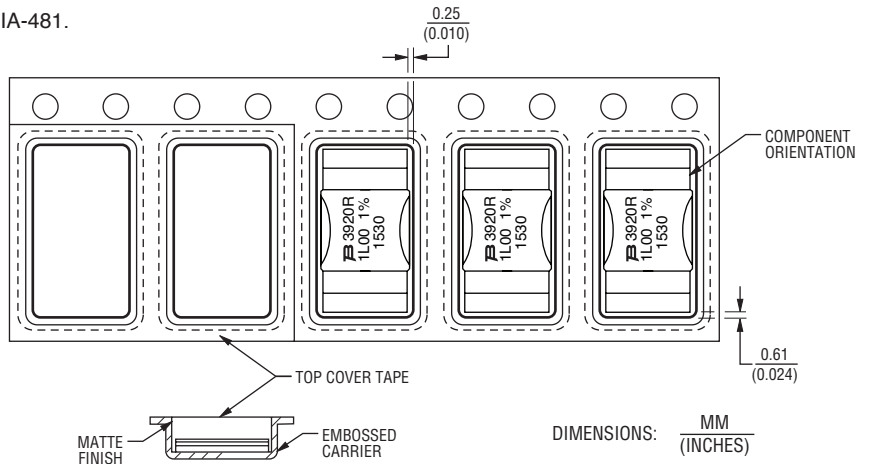

**BOURNS®**

Asia-Pacific: Tel: +886-2 2562-4117 • Email: asiacus@bourns.com

EMEA: Tel: +36 88 520 390 • Email: eurocus@bourns.com

The Americas: Tel: +1-951 781-5500 • Email: americus@bourns.com

[www.bourns.com](http://www.bourns.com)

REV. 01/18

Specifications are subject to change without notice.

The device characteristics and parameters in this data sheet can and do vary in different applications and actual device performance may vary over time. Users should verify actual device performance in their specific applications.



## Features

- EB welded metal strip
- Very high power
- Excellent long term stability
- Low resistance, low TCR
- Low thermal EMF
- RoHS compliant\* and halogen free\*\*
- AEC-Q200 compliant

## Applications

- Current sensing
- Voltage division
- Battery management systems
- Power modules
- Frequency converters
- Industrial

# Model CSS2H-5930 Series Current Sense Resistor

### Electrical Characteristics

Characteristic	Model CSS2H-5930 Series	
	Resistance Range / Power Rating @70 °C <sup>1</sup> / Power Rating @130 °C <sup>1</sup>	CSS2H-5930C-000 <sup>3</sup>
CSS2H-5930R-L200x		0.2 mΩ / 15 W / 10 W
CSS2H-5930R-L300x		0.3 mΩ / 15 W / 10 W
CSS2H-5930R-L500x		0.5 mΩ / 8 W / 6 W
CSS2H-5930K-1L00x		1.0 mΩ / 9 W / 6 W
CSS2H-5930K-2L00x		2.0 mΩ / 7 W / 4 W
CSS2H-5930K-3L00x		3.0 mΩ / 6 W / 4 W
Operating Temperature Range	-55 to +170 °C	
TCR - Resistive Alloy <sup>2</sup>	±50 PPM/°C (20~60 °C)	
Temperature Coefficient including Copper Terminals	CSS2H-5930R-L200x	±150 PPM/°C
	CSS2H-5930R-L300x	±150 PPM/°C
	CSS2H-5930R-L500x	±100 PPM/°C
	CSS2H-5930K-1L00x	±75 PPM/°C
	CSS2H-5930K-2L00x	±75 PPM/°C
	CSS2H-5930K-3L00x	±75 PPM/°C
Inductance	< 3 nH	
Resistance Tolerance	±1 %, ±5 %	

<sup>1</sup> Terminal temperature

<sup>2</sup> For full TCR range, refer to TCR curve

<sup>3</sup> Tinned copper

### How to Order

**CSS 2H - 5930 K - 1L00 F**

Model

No. of Terminals  
& Style

Size

Material Type   
(See Part Number Table)

Resistance Code (milliohms)   
"L" represents decimal point  
(examples: L500 = .500 milliohms;  
1L00 = 1.00 milliohms)

Resistance Tolerance   
F = ±1 %  
J = ±5 %

Packaging Size   
Blank = Standard 13" reel  
E = Mini 7" reel

### Environmental Characteristics

Characteristic	Test Condition	ΔR Max.
Thermal Shock	-55 to +150 °C / 2000 Cycles	0.50 %
Short Time Overload	5 Times Rated Power for 5 Second Duration	0.50 %
Resistance to Soldering Heat	+260 °C / 10 Seconds	0.50 %
High Temperature Exposure	+170 °C / 2000 Hours	1.00 %
Low Temperature Storage	-65 °C / 24 Hours	0.10 %
Biased Humidity Test	+85 °C, 85 %R.H., 1000 Hours	0.50 %
Moisture Resistance	10 Days with Cold Shock, No Load	0.20 %
Mechanical Shock	100 g, 6 ms half sine	0.20 %
Vibration, High Frequency	20 g, 10-2000 Hz	0.20 %
Load Life	2000 Hours, Max. Load, Terminal Temperature 130 °C	1.00 %
Solderability	J-STD-002	95 % Coverage Min.
ESD	AEC-Q200-002, 25 kV	0.25 %
Board Flex	60 Sec. Min. Holding Time	0.25 %
Moisture Sensitivity Level		Level 1
ESD Classification (HBM)		6

\* RoHS Directive 2002/95/EC Jan. 27, 2003 including annex and RoHS Recast 2011/65/EU June 8, 2011.

\*\*Bourns considers a product to be "halogen free" if (a) the Bromine (Br) content is 900 ppm or less; (b) the Chlorine (Cl) content is 900 ppm or less; and (c) the total Bromine (Br) and Chlorine (Cl) content is 1500 ppm or less.

Specifications are subject to change without notice.

The device characteristics and parameters in this data sheet can and do vary in different applications and actual device performance may vary over time.

Users should verify actual device performance in their specific applications.

# Model CSS2H-5930 Series Current Sense Resistor

**BOURNS®**

## Product Dimensions

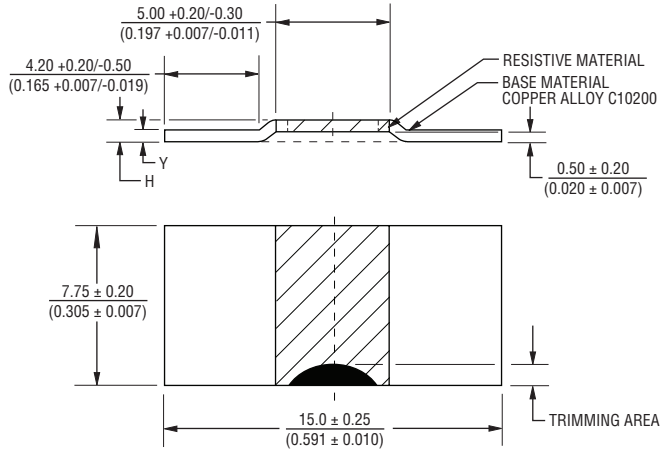

DIMENSIONS:  $\frac{\text{MM}}{\text{(INCHES)}}$

Part Number	Dimension H	Dimension Y
CSS2H-5930C-000	$\frac{0.92 \pm 0.10}{(0.036 \pm 0.004)}$	$\frac{0.42 \pm 0.10}{(0.016 \pm 0.004)}$
CSS2H-5930R-L200x	$\frac{1.80 \pm 0.10}{(0.071 \pm 0.004)}$	$\frac{1.20 \pm 0.20}{(0.047 \pm 0.008)}$
CSS2H-5930R-L300x	$\frac{1.36 \pm 0.10}{(0.057 \pm 0.004)}$	$\frac{0.84 \pm 0.10}{(0.033 \pm 0.004)}$
CSS2H-5930R-L500x	$\frac{1.10 \pm 0.10}{(0.043 \pm 0.004)}$	$\frac{0.42 \pm 0.10}{(0.016 \pm 0.004)}$
CSS2H-5930K-1L00x	$\frac{1.42 \pm 0.10}{(0.056 \pm 0.004)}$	$\frac{0.84 \pm 0.10}{(0.033 \pm 0.004)}$
CSS2H-5930K-2L00x	$\frac{0.96 \pm 0.10}{(0.038 \pm 0.004)}$	$\frac{0.42 \pm 0.10}{(0.016 \pm 0.004)}$
CSS2H-5930K-3L00x	$\frac{0.92 \pm 0.10}{(0.036 \pm 0.004)}$	$\frac{0.42 \pm 0.10}{(0.016 \pm 0.004)}$

## Recommended Pad Layout

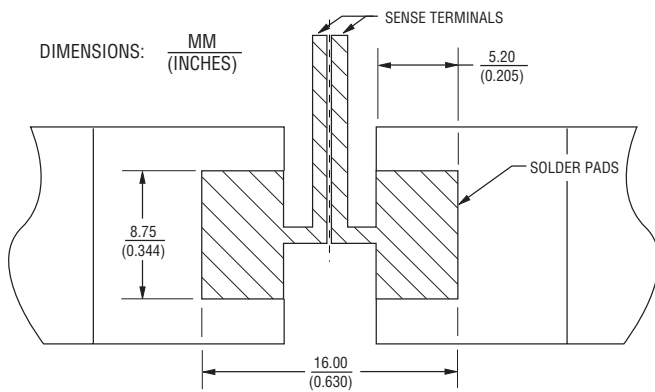

## Recommended Measurements

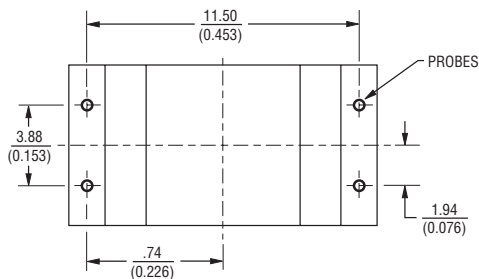

## Typical Part Marking

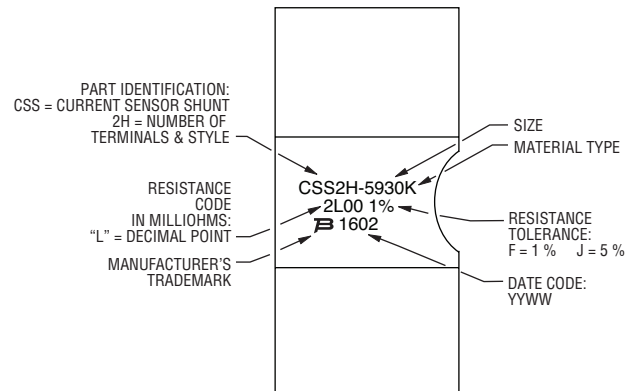

Specifications are subject to change without notice.

The device characteristics and parameters in this data sheet can and do vary in different applications and actual device performance may vary over time. Users should verify actual device performance in their specific applications.

# Model CSS2H-5930 Series Current Sense Resistor

**BOURNS®**

## TCR Curves

**K-Type Resistive Material**

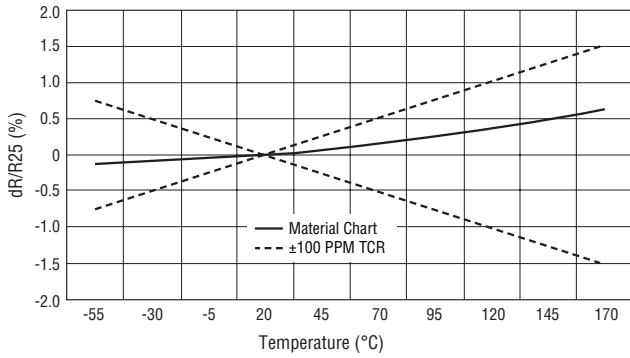

**R-Type Resistive Material**

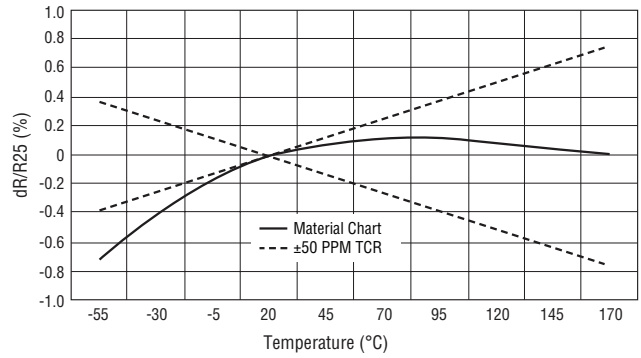

**K-Type Resistive Material**

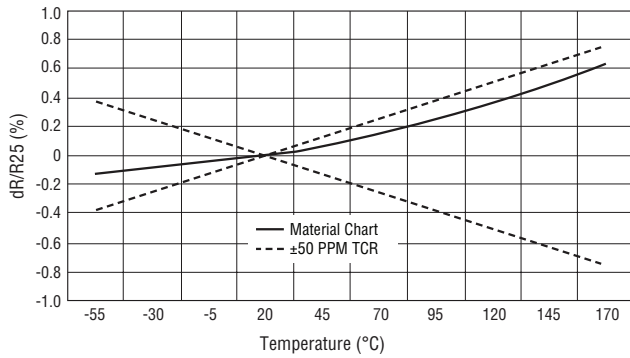

**R-Type Resistive Material**

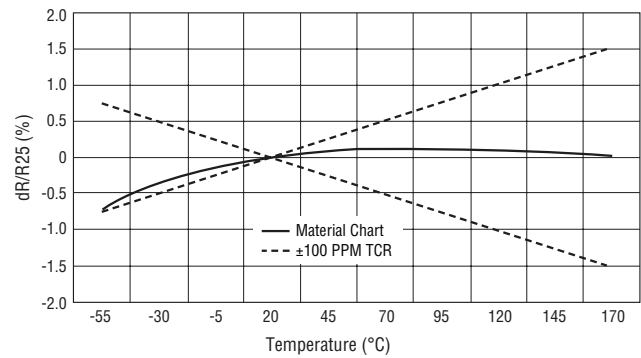

## Power Derating Curves

**@70 °C**

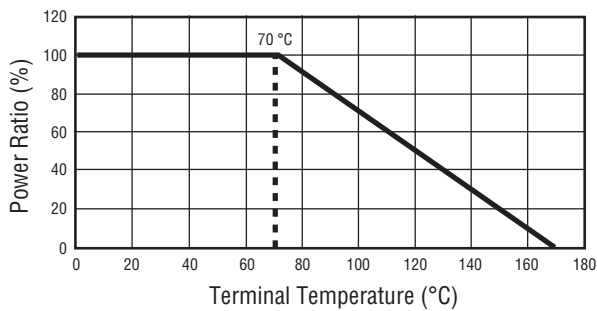

**@130 °C**

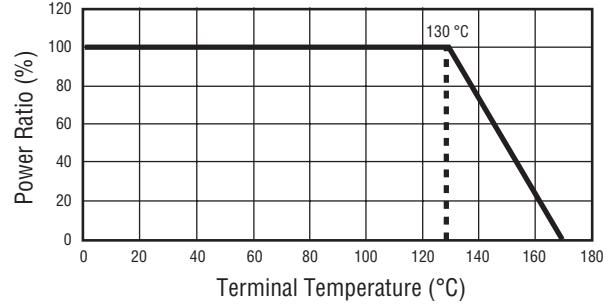

Specifications are subject to change without notice. The device characteristics and parameters in this data sheet can and do vary in different applications and actual device performance may vary over time. Users should verify actual device performance in their specific applications.

# Model CSS2H-5930 Series Current Sense Resistor

**BOURNS®**

## Maximum Pulse Power

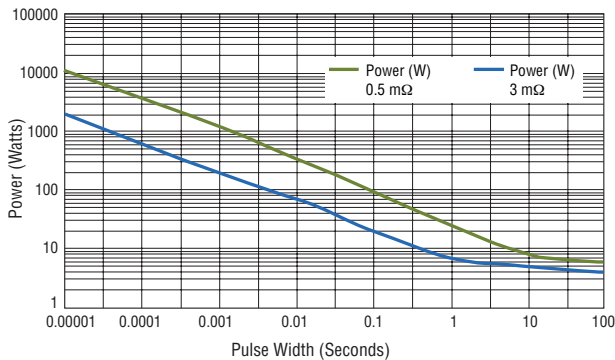

## Maximum Pulse Energy

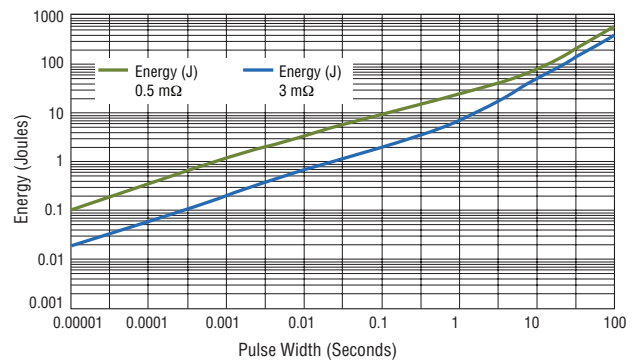

## Packaging Specifications

Components packaged on plastic tape & reel per EIA-481.

Standard Reel Size: 13 inches  
Tape Width: 24 mm  
Quantity: 1,500 pcs. per reel

Mini-Reel Size: 7 inches  
Tape Width: 24 mm  
Quantity: 500 pcs. per reel

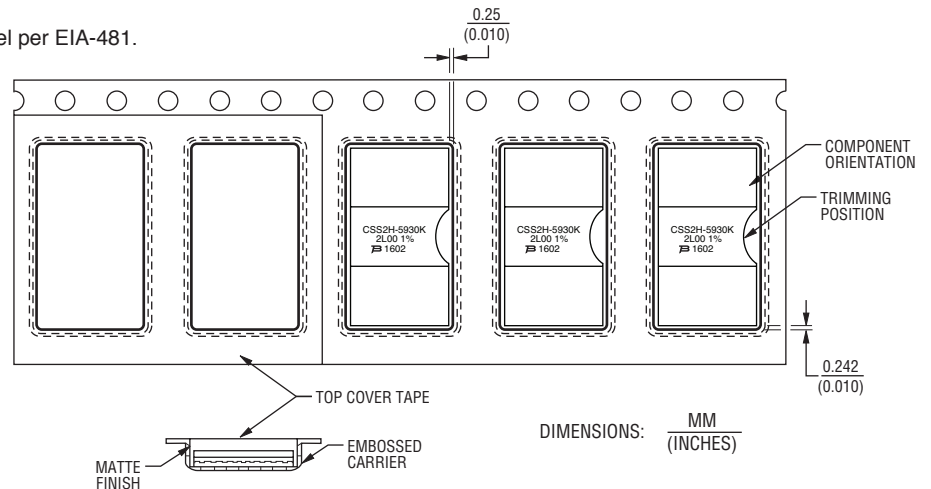

**BOURNS®**

Asia-Pacific: Tel: +886-2 2562-4117 • Email: asiacus@bourns.com

EMEA: Tel: +36 88 520 390 • Email: eurocus@bourns.com

The Americas: Tel: +1-951 781-5500 • Email: americus@bourns.com

[www.bourns.com](http://www.bourns.com)

REV. 01/18

Specifications are subject to change without notice.

The device characteristics and parameters in this data sheet can and do vary in different applications and actual device performance may vary over time.

Users should verify actual device performance in their specific applications.



## Features

- EB welded metal strip
- Very high power
- Excellent long term stability
- Low resistance, low TCR
- Low thermal EMF
- RoHS compliant\* and halogen free\*\*
- AEC-Q200 compliant

## Applications

- Current sensing
- Voltage division
- Battery management systems
- Power modules
- Frequency converters
- Industrial

# Model CSS4J-4026 Series Current Sense Resistor

### Electrical Characteristics

Characteristic	Model CSS4J-4026 Series	
	Resistance Range / Power Rating @70 °C <sup>1</sup> / Power Rating @130 °C <sup>1</sup>	CSS4J-4026R-L200x
CSS4J-4026R-L300x		0.3 mΩ / 5 W
CSS4J-4026R-L500x		0.5 mΩ / 5 W
CSS4J-4026R-1L00x		1.0 mΩ / 4 W
CSS4J-4026K-2L00x		2.0 mΩ / 4 W
CSS4J-4026K-3L00x		3.0 mΩ / 3 W
CSS4J-4026K-5L00x		5.0 mΩ / 3 W
Operating Temperature Range	-55 to +170 °C	
TCR - Resistive Alloy <sup>2</sup>	±50 PPM/°C (20~60 °C)	
Temperature Coefficient	CSS4J-4026R-L200x	±150 PPM/°C
	CSS4J-4026R-L300x	±100 PPM/°C
	CSS4J-4026R-L500x	±100 PPM/°C
	CSS4J-4026R-1L00x	±75 PPM/°C
	CSS4J-4026K-2L00x	±75 PPM/°C
	CSS4J-4026K-3L00x	±75 PPM/°C
	CSS4J-4026K-5L00x	±75 PPM/°C
Inductance	< 3 nH	
Resistance Tolerance	±1 %, ±5 %	

<sup>1</sup> Terminal temperature

<sup>2</sup> For full TCR range, refer to TCR curve

### How to Order

CSS 4J - 4026 R - 1L00 F	
Model	_____
No. of Terminals & Style	_____
Size	_____
Material Type	_____
(See Part Number Table)	
Resistance Code (milliohms)	_____
"L" represents decimal point (examples: L500 = .500 milliohms; 1L00 = 1.00 milliohms)	
Resistance Tolerance	_____
F = ±1 % J = ±5 %	
Packaging size	_____
Blank = Standard 13 " reel E = Mini 7 " reel	

### Environmental Characteristics

Characteristic	Test Condition	ΔR Max.
Thermal Shock	-55 to +150 °C / 2000 Cycles	0.50 %
Short Time Overload	5 Times Rated Power for 5 Second Duration	0.50 %
Resistance to Soldering Heat	+260 °C / 10 Seconds	0.50 %
High Temperature Exposure	+170 °C / 2000 Hours	1.00 %
Low Temperature Storage	-65 °C / 24 Hours	0.10 %
Biased Humidity Test	+85 °C, 85 %R.H., 1000 Hours	0.50 %
Moisture Resistance	10 Days with Cold Shock, No Load	0.20 %
Mechanical Shock	100 g, 6 ms half sine	0.20 %
Vibration, High Frequency	20 g, 10-2000 Hz	0.20 %
Load Life	2000 Hours, Max. Load, Terminal Temperature 130 °C	1.00 %
Solderability	J-STD-002	95 % Coverage Min.
ESD	AEC-Q200-002, 25 kV	0.25 %
Board Flex	60 Sec. Min. Holding Time	0.25 %
Moisture Sensitivity Level		Level 1
ESD Classification (HBM)		6

\* RoHS Directive 2002/95/EC Jan. 27, 2003 including annex and RoHS Recast 2011/65/EU June 8, 2011.

\*\*Bourns considers a product to be "halogen free" if (a) the Bromine (Br) content is 900 ppm or less; (b) the Chlorine (Cl) content is 900 ppm or less; and (c) the total Bromine (Br) and Chlorine (Cl) content is 1500 ppm or less.

Specifications are subject to change without notice.

The device characteristics and parameters in this data sheet can and do vary in different applications and actual device performance may vary over time.

Users should verify actual device performance in their specific applications.

# Model CSS4J-4026 Series Current Sense Resistor

**BOURNS®**

## Product Dimensions

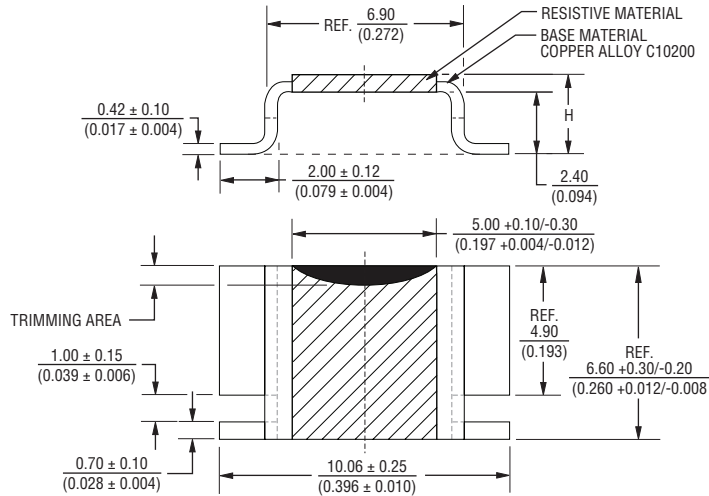

Part Number	Dimension H
CSS4J-4026R-L200x	$3.59 \pm 0.20$ (0.141 ± 0.008)
CSS4J-4026R-L300x	$3.45 \pm 0.20$ (0.136 ± 0.008)
CSS4J-4026R-L500x	$3.01 \pm 0.20$ (0.119 ± 0.008)
CSS4J-4026R-1L00x	$2.82 \pm 0.20$ (0.111 ± 0.008)
CSS4J-4026K-2L00x	$2.94 \pm 0.20$ (0.116 ± 0.008)
CSS4J-4026K-3L00x	$2.82 \pm 0.20$ (0.111 ± 0.008)
CSS4J-4026K-5L00x	$2.82 \pm 0.20$ (0.111 ± 0.008)

DIMENSIONS:  $\frac{\text{MM}}{\text{(INCHES)}}$

## Recommended Pad Layout

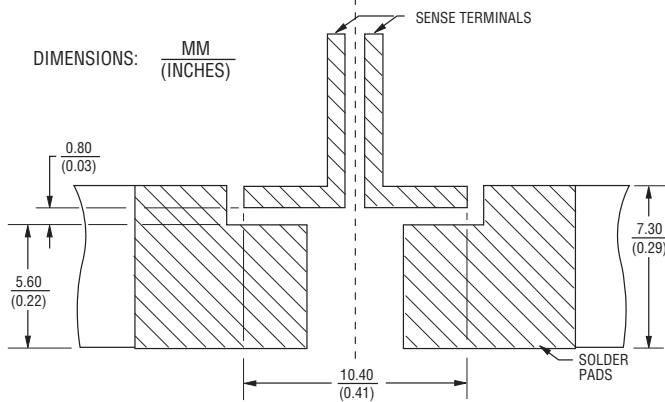

## Typical Part Marking

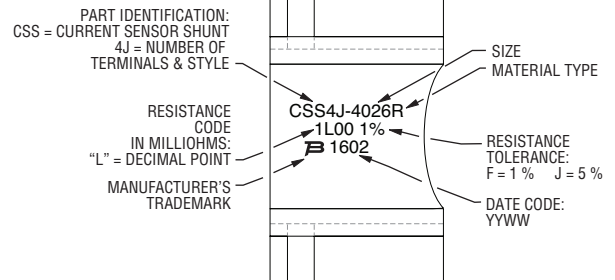

## Recommended Measurements

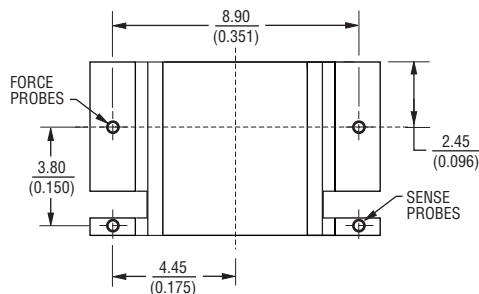

Specifications are subject to change without notice.

The device characteristics and parameters in this data sheet can and do vary in different applications and actual device performance may vary over time. Users should verify actual device performance in their specific applications.

# Model CSS4J-4026 Series Current Sense Resistor



## TCR Curves

K-Type Resistive Material

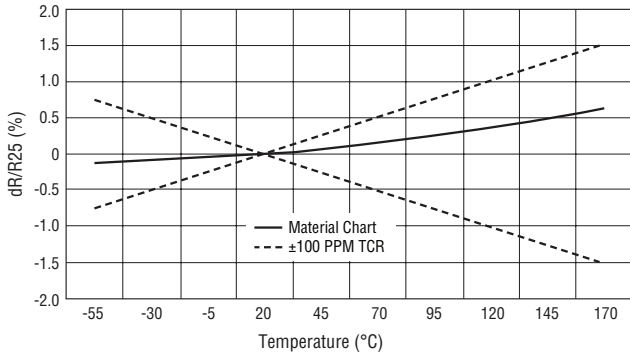

R-Type Resistive Material

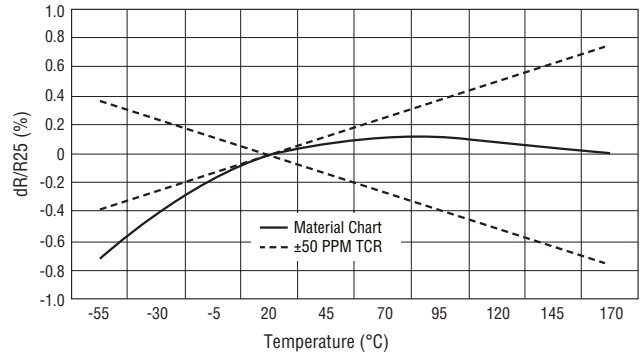

K-Type Resistive Material

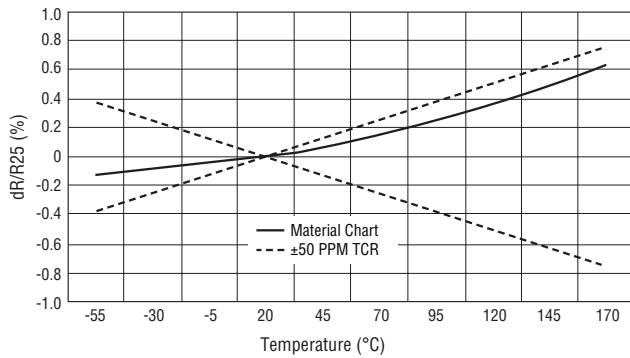

R-Type Resistive Material

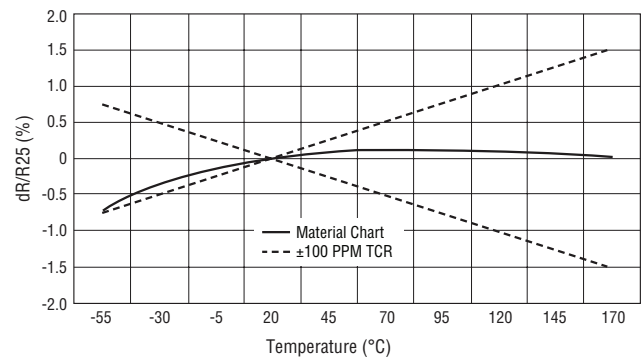

## Power Derating Curves

@70 °C

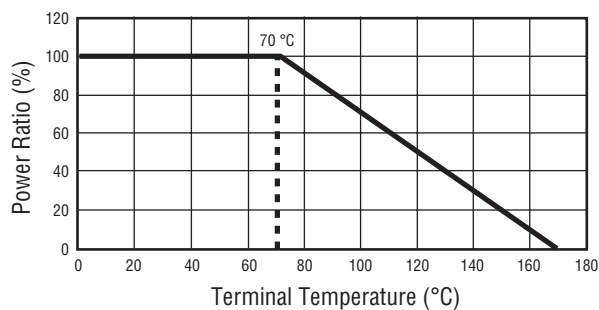

@130 °C

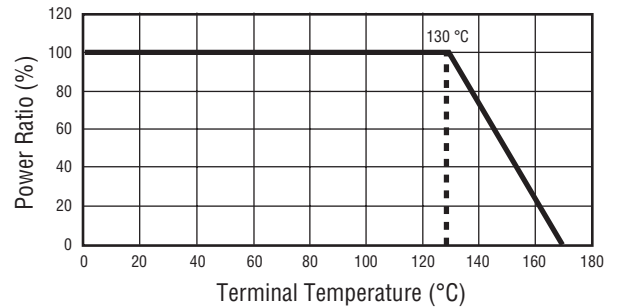

Specifications are subject to change without notice.  
The device characteristics and parameters in this data sheet can and do vary in different applications and actual device performance may vary over time.  
Users should verify actual device performance in their specific applications.

# Model CSS4J-4026 Series Current Sense Resistor

**BOURNS®**

## Maximum Pulse Power

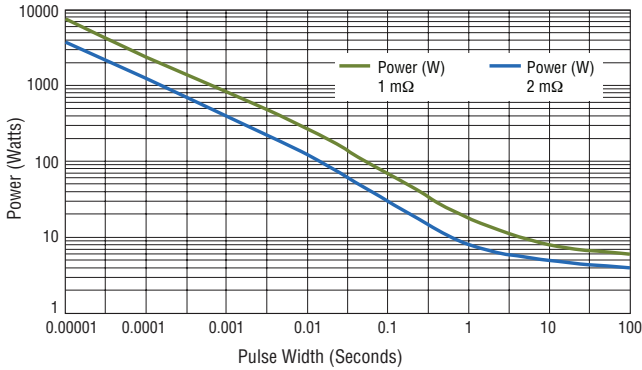

## Maximum Pulse Energy

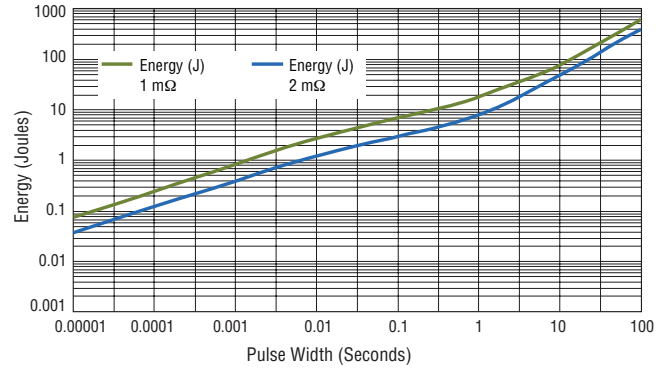

## Packaging Specifications

Components packaged on plastic tape & reel per EIA-481.

Standard Reel Size: 13 inches  
 Tape Width: 16 mm  
 Quantity: 1,500 pcs. per reel

Mini-Reel Size: 7 inches  
 Tape Width: 16 mm  
 Quantity: 400 pcs. per reel

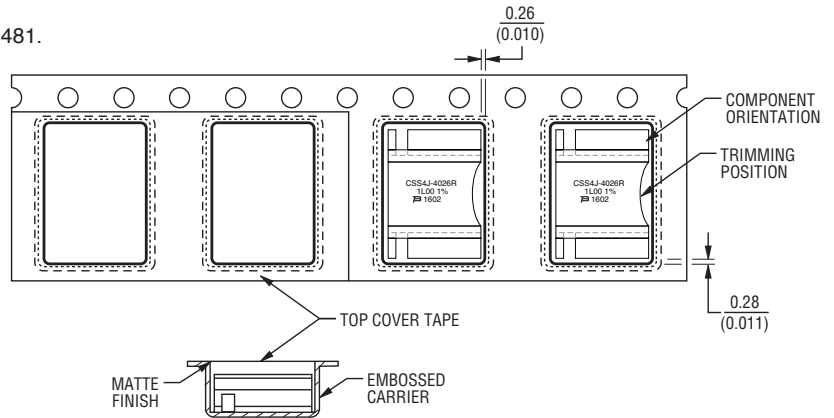

DIMENSIONS:  $\frac{\text{MM}}{\text{(INCHES)}}$

**BOURNS®**

Asia-Pacific: Tel: +886-2 2562-4117 • Email: asiacus@bourns.com

EMEA: Tel: +36 88 520 390 • Email: eurocus@bourns.com

The Americas: Tel: +1-951 781-5500 • Email: americus@bourns.com

www.bourns.com

REV. 01/18

Specifications are subject to change without notice.

The device characteristics and parameters in this data sheet can and do vary in different applications and actual device performance may vary over time. Users should verify actual device performance in their specific applications.