



Features

- Thick film technology
- Power rating up to 3 watts @ 70 °C
- High power surge withstanding
- RoHS compliant*
- Halogen free**
- AEC-Q200 compliant
- Sulfur-resistant design (ASTM-B809)

Applications

- Power supplies
- Digital meters
- Consumer electronics
- LED lighting
- Industry control boards

CHP-A Series Ultra-High Power Chip Resistors

Electrical Characteristics

Characteristic	Model			
	CHP0603A	CHP0805A	CHP1206A	CHP2512A
Power Rating @ 70 °C	0.33 W	0.5 W	0.75 W	3 W
Operating Temperature Range	-55 °C to +155 °C			
Derated to Zero Load at	+155 °C			
Maximum Working Voltage	75 V	200 V	250 V	250 V
Maximum Overload Voltage	125 V	300 V	500 V	500 V
Resistance Tolerance	±1 %, ±5 %			
Temperature Coefficient				
10 ohms to 1 megohm (±1 %, E24 & E96 Series)	±100 ppm/°C	±100 ppm/°C	±100 ppm/°C	±100 ppm/°C
10 ohms to 1 megohm (±5 %, E24 Series)	±200 ppm/°C	±200 ppm/°C	±200 ppm/°C	±200 ppm/°C

Note: Solder pad and trace size should be evaluated and board surface temperature should not exceed +105 °C when applying full rated power.

For Standard Values Used in Capacitors, Inductors and Resistors, [click here](#).



WARNING Cancer and Reproductive Harm - www.P65Warnings.ca.gov

* RoHS Directive 2015/863, Mar 31, 2015 and Annex.

** Bourns considers a product to be "halogen free" if (a) the Bromine (Br) content is 900 ppm or less; (b) the Chlorine (Cl) content is 900 ppm or less; and (c) the total Bromine (Br) and Chlorine (Cl) content is 1500 ppm or less.

Specifications are subject to change without notice.

Users should verify actual device performance in their specific applications.

The products described herein and this document are subject to specific legal disclaimers as set forth on the last page of this document, and at www.bourns.com/docs/legal/disclaimer.pdf.

CHP-A Series Ultra-High Power Chip Resistors

BOURNS®

Product Dimensions

Model	L	W	C	D	T
CHP0603A	$\frac{1.60 \pm 0.10}{(.063 \pm .004)}$	$\frac{0.80 \pm 0.10}{(.031 \pm .004)}$	$\frac{0.30 \pm 0.20}{(.012 \pm .008)}$	$\frac{0.30 \pm 0.20}{(.012 \pm .008)}$	$\frac{0.45 \pm 0.10}{(.018 \pm .004)}$
CHP0805A	$\frac{2.00 \pm 0.10}{(.079 \pm .004)}$	$\frac{1.25 \pm 0.10}{(.049 \pm .004)}$	$\frac{0.40 \pm 0.20}{(.016 \pm .008)}$	$\frac{0.40 \pm 0.20}{(.016 \pm .008)}$	$\frac{0.50 \pm 0.10}{(.020 \pm .004)}$
CHP1206A	$\frac{3.10 \pm 0.10}{(.122 \pm .004)}$	$\frac{1.60 \pm 0.10}{(.063 \pm .004)}$	$\frac{0.50 \pm 0.25}{(.020 \pm .010)}$	$\frac{0.50 \pm 0.25}{(.020 \pm .010)}$	$\frac{0.55 \pm 0.10}{(.022 \pm .004)}$
CHP2512A	$\frac{6.40 \pm 0.20}{(.252 \pm .008)}$	$\frac{3.10 \pm 0.20}{(.122 \pm .008)}$	$\frac{0.45 \pm 0.25}{(.018 \pm .010)}$	$\frac{1.80 \pm 0.25}{(.071 \pm .010)}$	$\frac{1.10 \pm 0.20}{(.043 \pm .008)}$

DIMENSIONS: $\frac{\text{MM}}{\text{(INCHES)}}$

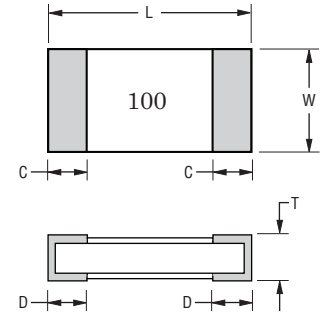

Recommended Solder Pad Layout

Model	A	B	L
CHP0603A	$\frac{0.90}{(.035)}$	$\frac{1.00}{(.039)}$	$\frac{3.00}{(.118)}$
CHP0805A	$\frac{1.30}{(.051)}$	$\frac{1.15}{(.045)}$	$\frac{3.50}{(.138)}$
CHP1206A	$\frac{1.80}{(.071)}$	$\frac{1.30}{(.051)}$	$\frac{4.70}{(.185)}$
CHP2512A	$\frac{3.70}{(.146)}$	$\frac{2.45}{(.096)}$	$\frac{7.60}{(.299)}$

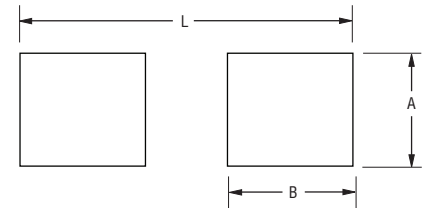

DIMENSIONS: $\frac{\text{MM}}{\text{(INCHES)}}$

Surge Performance

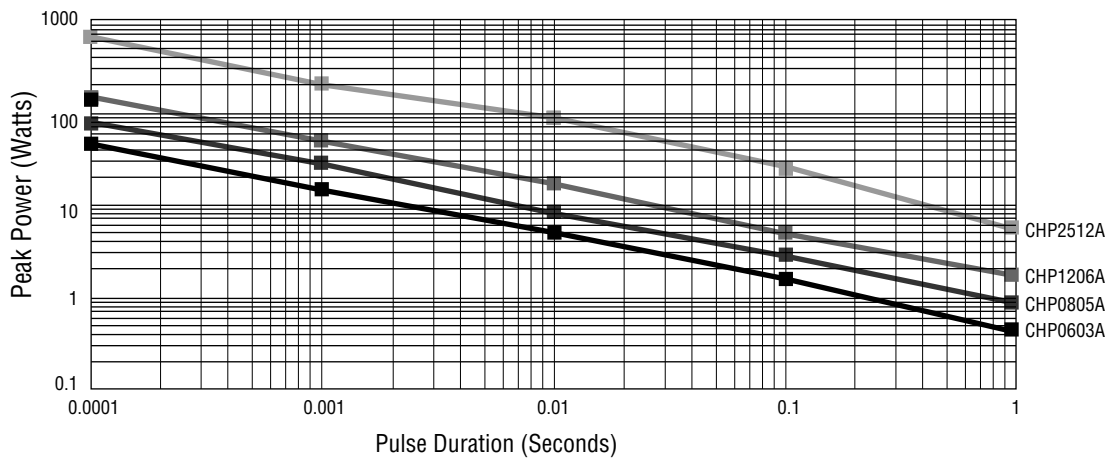

Specifications are subject to change without notice.

Users should verify actual device performance in their specific applications.

The products described herein and this document are subject to specific legal disclaimers as set forth on the last page of this document, and at www.bourns.com/docs/legal/disclaimer.pdf.

CHP-A Series Ultra-High Power Chip Resistors



Construction

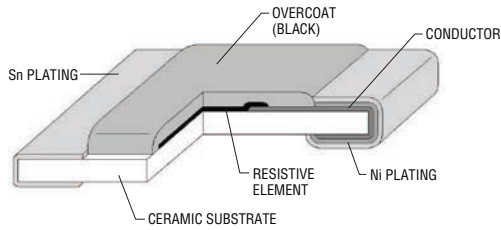

Rated Voltage

The rated voltage is calculated by the following formula:

$$V = \sqrt{P \times R}$$

V: Rated Voltage (V)
P: Rated Power (W)
R: Resistance Value (Ω)

Environmental Characteristics

Moisture Sensitivity Level..... 1

Derating Curve

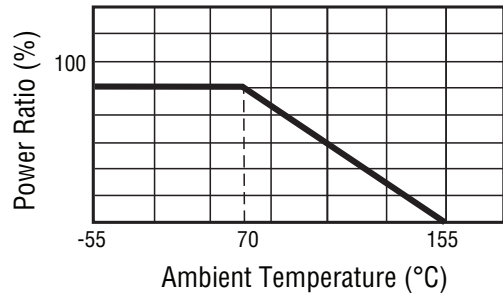

Soldering Profile

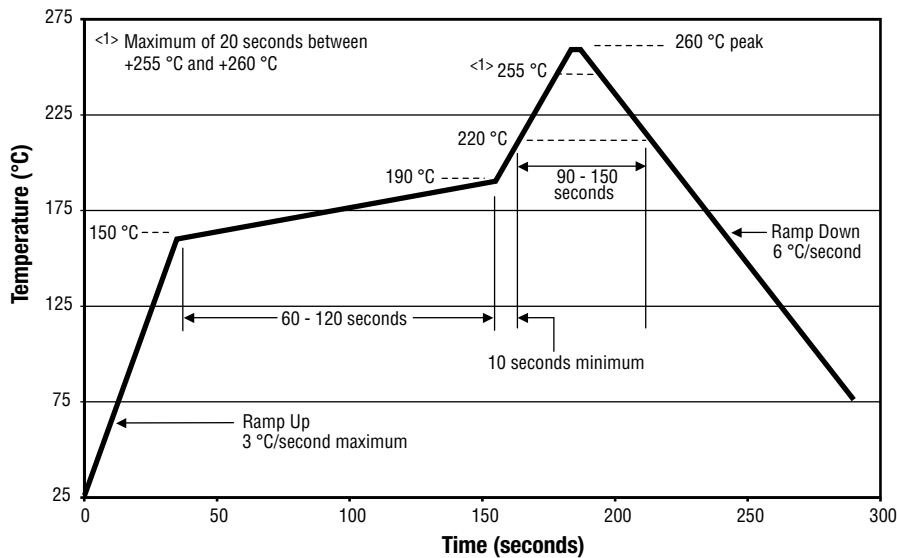

CHP-A Series Ultra-High Power Chip Resistors

BOURNS®

How to Order

CHP 0603 A F X - 1002 E LF

Model _____
CHP = High Power Surge Resistor

Size _____
0603 = 0603 Size
0805 = 0805 Size
1206 = 1206 Size
2512 = 2512 Size

Feature _____
A = AEC-Q200 Compliant

Resistance Tolerance _____
F = $\pm 1\%$
J = $\pm 5\%$

TCR (See Electrical Characteristics chart) _____
W = ± 200 PPM/ $^{\circ}$ C
X = ± 100 PPM/ $^{\circ}$ C

Resistance Value _____
1 % Tolerance:
<100 ohms.....“R” represents decimal point (*example: 24R3 = 24.3 ohms*)
 ≥ 100 ohms.....First three digits are significant, fourth digit represents number of zeros to follow
(*example: 8252 = 82.5K ohms*)
5 % Tolerance:
 ≥ 10 ohms.....First two digits are significant, third digit represents number of zeros to follow
(*example: 474 = 470K ohms*)

Packaging _____
E = 5,000 pieces on 180 mm (7 inch) plastic reel, paper tape - CHP0603, CHP0805, CHP1206
3,000 pieces on 180 mm (7 inch) reel, plastic tape - CHP2512

Termination _____
LF = Tin-plated (RoHS Compliant)

Specifications are subject to change without notice.

Users should verify actual device performance in their specific applications.

The products described herein and this document are subject to specific legal disclaimers as set forth on the last page of this document, and at www.bourns.com/docs/legal/disclaimer.pdf.

CHP-A Series Ultra-High Power Chip Resistors

BOURNS®

Performance Characteristics

Test Item	Method	Procedure	Test Limits ΔR
Electrical Characteristics	AEC-Q200 Table 7.1	Measure the resistance value	DC Resistance: F: $\pm 1\%$; J : $\pm 5\%$ TCR: Within the specified
High Temperature Exposure (Storage)	AEC-Q200 Table 7.3	1000 hours @ T = 125 °C unpowered; Measurement at 24 ± 2 hours after test conclusion	J: $\Delta R \leq \pm(3\% + 0.1 \Omega)$ F: $\Delta R \leq \pm(1\% + 0.05 \Omega)$
Temperature Cycling	AEC-Q200 Table 7.4	1000 cycles (-55 °C to +125 °C); Measurement at 24 ± 2 hours after test conclusion	J: $\Delta R \leq \pm(1\% + 0.1 \Omega)$ F: $\Delta R \leq \pm(0.5\% + 0.05 \Omega)$ No mechanical damage
Moisture Resistance	AEC-Q200 Table 7.6	Test 65 °C / 80-100 % RH / 10 cycles; Measurement at 24 ± 2 hours after test conclusion (t = 24 hours/cycle)	J: $\Delta R \leq \pm(1\% + 0.1 \Omega)$ F: $\Delta R \leq \pm(0.5\% + 0.05 \Omega)$
Biased Humidity	AEC-Q200 Table 7.7	1000 hours 85 °C / 85 % RH, 10 % of operating power; Measurement at 24 ± 2 hours after test conclusion	J: $\Delta R \leq \pm(3\% + 0.1 \Omega)$ F: $\Delta R \leq \pm(1\% + 0.05 \Omega)$
Operational Life	AEC-Q200 Table 7.8	Test 1000 hours @ TA = 125 °C at specified rated power; Measurement at 24 ± 2 hours after test conclusion	J: $\Delta R \leq \pm(3\% + 0.1 \Omega)$ F: $\Delta R \leq \pm(1\% + 0.05 \Omega)$
Mechanical Shock	AEC-Q200 Table 7.13	Test peak value: 100 g's, wave: hail-sine; Duration: 6 ms, Velocity: 12.3 ft/sec.	Within product specification tolerance and no visible damage
Vibration	AEC-Q200 Table 7.14	5 g's for 20 min., 12 cycles each of 3 orientations; Test from 10-2000 Hz	J: $\Delta R \leq \pm(1\% + 0.1 \Omega)$ F: $\Delta R \leq \pm(0.5\% + 0.05 \Omega)$ No mechanical damage
Resistance to Solder Heat	AEC-Q200 Table 7.15	Solder dipping @ 270 °C ± 5 °C for 10 sec. ± 1 sec.	J: $\Delta R \leq \pm(1\% + 0.1 \Omega)$ F: $\Delta R \leq \pm(0.5\% + 0.05 \Omega)$ No mechanical damage
Thermal Shock	AEC-Q200 Table 7.16	-55 to 155 °C / dwell time 15 min / max transfer time 20 sec / 300 cycles	J: $\Delta R \leq \pm(1\% + 0.1 \Omega)$ F: $\Delta R \leq \pm(0.5\% + 0.05 \Omega)$ No mechanical damage
ESD	AEC-Q200-002	Test contact min. 1 KV	$\Delta R \leq \pm(1\% + 0.1 \Omega)$
Solderability	AEC-Q200 Table 7.18	a) Baking 155 °C 4H, dipping 235 °C 5 sec b) Steam 8H, dipping 215 °C 5 sec c) Steam 8H, dipping 260 °C 7 sec	Over 95 % of termination must be covered with solder
Flammability	AEC-Q200 Table 7.20	UL-94 V-0 or V-1 are acceptable	Refer UL-94
Board Flex	AEC-Q200 Table 7.21	Bending 2 mm (2512, 1206), 3 mm (0805, 0603)	J: $\Delta R \leq \pm(1\% + 0.1 \Omega)$ F: $\Delta R \leq \pm(0.5\% + 0.05 \Omega)$ No mechanical damage
Terminal Strength	AEC-Q200 Table 7.22	Force 1.8 Kg for 60 sec	No mechanical damage
Sulfur-Resistant	ASTM B-809	+50 °C ± 2 °C, 1000 hours	$\Delta R \leq \pm(1\% + 0.1 \Omega)$

Specifications are subject to change without notice.

Users should verify actual device performance in their specific applications.

The products described herein and this document are subject to specific legal disclaimers as set forth on the last page of this document, and at www.bourns.com/docs/legal/disclaimer.pdf.

CHP-A Series Ultra-High Power Chip Resistors

BOURNS®

Typical Part Marking

±5 % (E24):

CHP0603A, CHP0805A, CHP1206A, CHP2512A

Resistance value is expressed by 3 digits. The first two digits represent the significant figures of the nominal resistance value in ohms; the third digit represents the exponent for a base of 10.

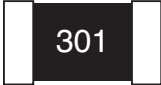

Example: **301** = $30 \times 10^1 = 300 \text{ ohms}$

±1 % (E24/E96):

CHP0805A, CHP1206A, CHP2512A

Resistance value is expressed by 4 digits. The first three digits represent the significant figures of the nominal resistance value in ohms; the third digit represents the exponent for a base of 10.

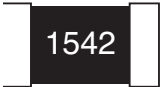

Example: **1542** = $154 \times 10^2 = 15.4K \text{ ohms}$

±1 % (E24):

CHP0603A

Resistance value is expressed by 3 digits. The first two digits represent the significant figures of the nominal resistance value in ohms; the third digit represents the exponent for a base of 10.



Example: **222** = $22 \times 10^2 = 2.2K \text{ ohms}$

±1 % (E96):

CHP0603A

Resistance value is expressed by 2 digits followed by an alpha character multiplier. (Refer to marking table below.)



Example: **01B** = $100 \times 10^1 = 1K \text{ ohms}$

Code	R Value	Code	R Value	Code	R Value	Code	R Value	Code	R Value	Code	R Value	Code	R Value	Code	R Value
01	100	13	133	25	178	37	237	49	316	61	422	73	562	85	750
02	102	14	137	26	182	38	243	50	324	62	432	74	576	86	768
03	105	15	140	27	187	39	249	51	332	63	442	75	590	87	787
04	107	16	143	28	191	40	255	52	340	64	453	76	604	88	806
05	110	17	147	29	196	41	261	53	348	65	464	77	619	89	825
06	113	18	150	30	200	42	267	54	357	66	475	78	634	90	845
07	115	19	154	31	205	43	274	55	365	67	487	79	649	91	866
08	118	20	158	32	210	44	280	56	374	68	499	80	665	92	887
09	121	21	162	33	215	45	287	57	383	69	511	81	681	93	909
10	124	22	165	34	221	46	294	58	392	70	523	82	698	94	931
11	127	23	169	35	226	47	301	59	402	71	536	83	715	95	953
12	130	24	174	36	232	48	309	60	412	72	549	84	732	96	976

This table shows the first two digits for the three-digit E96 part marking scheme. The third character is a letter multiplier: A=10⁰ B=10¹ C=10² D=10³ E=10⁴ F=10⁵ G=10⁶ H=10⁷ X=10⁻¹ Y=10⁻² Z=10⁻³

Specifications are subject to change without notice.

Users should verify actual device performance in their specific applications.

The products described herein and this document are subject to specific legal disclaimers as set forth on the last page of this document, and at www.bourns.com/docs/legal/disclaimer.pdf.

CHP-A Series Ultra-High Power Chip Resistors

BOURNS®

Packaging Dimensions (Conforms to EIA RS-481A)

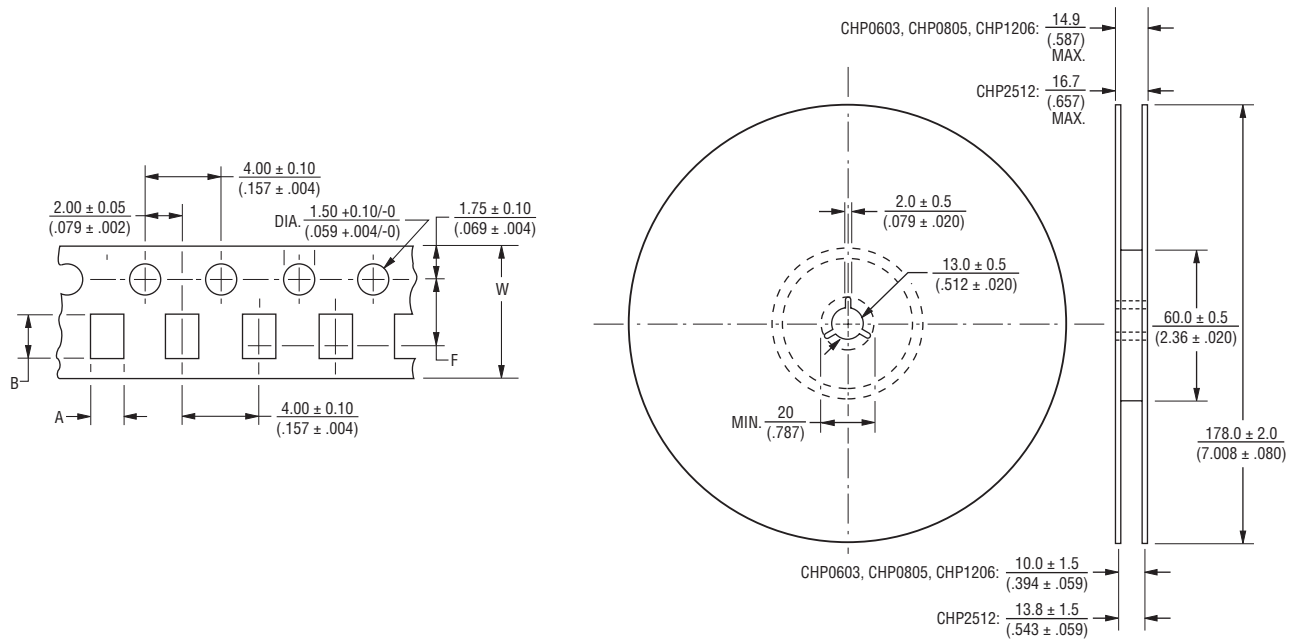

Model	Tape Type	Pieces per Reel	A	B	W	F
CHP0603A	Paper	5,000	1.10 ± 0.20 (.043 ± .008)	1.90 ± 0.20 (.075 ± .008)	8.00 ± 0.30 (.315 ± .012)	3.50 ± 0.05 (.138 ± .002)
CHP0805A			1.65 ± 0.20 (.065 ± .008)	2.40 ± 0.20 (.094 ± .008)		
CHP1206A			2.00 ± 0.20 (.079 ± .008)	3.60 ± 0.20 (.142 ± .008)		
CHP2512A	Plastic	3,000	3.50 ± 0.20 (.138 ± .008)	6.70 ± 0.20 (.264 ± .008)	12.00 ± 0.30 (.472 ± .012)	5.50 ± 0.05 (.217 ± .002)

DIMENSIONS: $\frac{\text{MM}}{\text{(INCHES)}}$

BOURNS®

Asia-Pacific: Tel: +886-2 2562-4117 • Email: asiacus@bourns.com

EMEA: Tel: +36 88 885 877 • Email: eurocus@bourns.com

The Americas: Tel: +1-951 781-5500 • Email: americus@bourns.com

www.bourns.com

REV. 05/29/20

Specifications are subject to change without notice.

Users should verify actual device performance in their specific applications.

The products described herein and this document are subject to specific legal disclaimers as set forth on the last page of this document, and at www.bourns.com/docs/legal/disclaimer.pdf.

This legal disclaimer applies to purchasers and users of Bourns® products manufactured by or on behalf of Bourns, Inc. and its affiliates (collectively, "Bourns").

Unless otherwise expressly indicated in writing, Bourns® products and data sheets relating thereto are subject to change without notice. Users should check for and obtain the latest relevant information and verify that such information is current and complete before placing orders for Bourns® products.

The characteristics and parameters of a Bourns® product set forth in its data sheet are based on laboratory conditions, and statements regarding the suitability of products for certain types of applications are based on Bourns' knowledge of typical requirements in generic applications. The characteristics and parameters of a Bourns® product in a user application may vary from the data sheet characteristics and parameters due to (i) the combination of the Bourns® product with other components in the user's application, or (ii) the environment of the user application itself. The characteristics and parameters of a Bourns® product also can and do vary in different applications and actual performance may vary over time. Users should always verify the actual performance of the Bourns® product in their specific devices and applications, and make their own independent judgments regarding the amount of additional test margin to design into their device or application to compensate for differences between laboratory and real world conditions.

Unless Bourns has explicitly designated an individual Bourns® product as meeting the requirements of a particular industry standard (e.g., ISO/TS 16949) or a particular qualification (e.g., UL listed or recognized), Bourns is not responsible for any failure of an individual Bourns® product to meet the requirements of such industry standard or particular qualification. Users of Bourns® products are responsible for ensuring compliance with safety-related requirements and standards applicable to their devices or applications.

Bourns® products are not recommended, authorized or intended for use in nuclear, lifesaving, life-critical or life-sustaining applications, nor in any other applications where failure or malfunction may result in personal injury, death, or severe property or environmental damage. Unless expressly and specifically approved in writing by two authorized Bourns representatives on a case-by-case basis, use of any Bourns® products in such unauthorized applications might not be safe and thus is at the user's sole risk. Life-critical applications include devices identified by the U.S. Food and Drug Administration as Class III devices and generally equivalent classifications outside of the United States.

Bourns expressly identifies those Bourns® standard products that are suitable for use in automotive applications on such products' data sheets in the section entitled "Applications." Unless expressly and specifically approved in writing by two authorized Bourns representatives on a case-by-case basis, use of any other Bourns® standard products in an automotive application might not be safe and thus is not recommended, authorized or intended and is at the user's sole risk. If Bourns expressly identifies a sub-category of automotive application in the data sheet for its standard products (such as infotainment or lighting), such identification means that Bourns has reviewed its standard product and has determined that if such Bourns® standard product is considered for potential use in automotive applications, it should only be used in such sub-category of automotive applications. Any reference to Bourns® standard product in the data sheet as compliant with the AEC-Q standard or "automotive grade" does not by itself mean that Bourns has approved such product for use in an automotive application.

Bourns® standard products are not tested to comply with United States Federal Aviation Administration standards generally or any other generally equivalent governmental organization standard applicable to products designed or manufactured for use in aircraft or space applications. Bourns expressly identifies Bourns® standard products that are suitable for use in aircraft or space applications on such products' data sheets in the section entitled "Applications." Unless expressly and specifically approved in writing by two authorized Bourns representatives on a case-by-case basis, use of any other Bourns® standard product in an aircraft or space application might not be safe and thus is not recommended, authorized or intended and is at the user's sole risk.

The use and level of testing applicable to Bourns® custom products shall be negotiated on a case-by-case basis by Bourns and the user for which such Bourns® custom products are specially designed. Absent a written agreement between Bourns and the user regarding the use and level of such testing, the above provisions applicable to Bourns® standard products shall also apply to such Bourns® custom products.

Users shall not sell, transfer, export or re-export any Bourns® products or technology for use in activities which involve the design, development, production, use or stockpiling of nuclear, chemical or biological weapons or missiles, nor shall they use Bourns® products or technology in any facility which engages in activities relating to such devices. The foregoing restrictions apply to all uses and applications that violate national or international prohibitions, including embargos or international regulations. Further, Bourns® products and Bourns technology and technical data may not under any circumstance be exported or re-exported to countries subject to international sanctions or embargoes. Bourns® products may not, without prior authorization from Bourns and/or the U.S. Government, be resold, transferred, or re-exported to any party not eligible to receive U.S. commodities, software, and technical data.

To the maximum extent permitted by applicable law, Bourns disclaims (i) any and all liability for special, punitive, consequential, incidental or indirect damages or lost revenues or lost profits, and (ii) any and all implied warranties, including implied warranties of fitness for particular purpose, non-infringement and merchantability.

For your convenience, copies of this Legal Disclaimer Notice with German, Spanish, Japanese, Traditional Chinese and Simplified Chinese bilingual versions are available at:

Web Page: <http://www.bourns.com/legal/disclaimers-terms-and-policies>

PDF: <http://www.bourns.com/docs/Legal/disclaimer.pdf>



Features

- Thick film technology
- Power rating up to 1.5 watts @ 70 °C
- High power surge withstanding
- RoHS compliant*
- Halogen free**

Applications

- Power supplies
- Digital meters
- Consumer electronics
- LED lighting
- Industry control boards

CMP Series High Power Anti-Surge Chip Resistors

Electrical Characteristics

Characteristic	Model				
	CMP0603	CMP0805	CMP1206	CMP2010	CMP2512
Power Rating @ 70 °C	0.25 W	0.5 W	0.75 W	1 W	1.5 W
Operating Temperature Range	-55 °C to +155 °C				
Derated to Zero Load at	+155 °C				
Maximum Working Voltage	75 V	200 V	250 V	200 V	300 V
Maximum Overload Voltage	125 V	300 V	500 V	400 V	600 V
Resistance Tolerance	±1 %, ±5 %				
Temperature Coefficient 10 Ω to 1 MΩ (±1 %, E24 & E96 Series)	±100 ppm/°C	±100 ppm/°C	±100 ppm/°C	±100 ppm/°C	±100 ppm/°C
10 Ω to 1 MΩ (±5 %, E24 Series)	±200 ppm/°C	±200 ppm/°C	±200 ppm/°C	±200 ppm/°C	±200 ppm/°C

Note: Solder pad and trace size should be evaluated and board surface temperature should not exceed +105 °C when applying full rated power.

BOURNS®

Asia-Pacific: Tel: +886-2 2562-4117 • Email: asiacus@bourns.com

EMEA: Tel: +36 88 885 877 • Email: eurocus@bourns.com

The Americas: Tel: +1-951 781-5500 • Email: americus@bourns.com

www.bourns.com



WARNING Cancer and Reproductive Harm - www.P65Warnings.ca.gov

* RoHS Directive 2015/863, Mar 31, 2015 and Annex.

** Bourns considers a product to be "halogen free" if (a) the Bromine (Br) content is 900 ppm or less; (b) the Chlorine (Cl) content is 900 ppm or less; and (c) the total Bromine (Br) and Chlorine (Cl) content is 1500 ppm or less.

Specifications are subject to change without notice.

Users should verify actual device performance in their specific applications.

The products described herein and this document are subject to specific legal disclaimers as set forth on the last page of this document, and at www.bourns.com/docs/legal/disclaimer.pdf.

CMP Series High Power Anti-Surge Chip Resistors

BOURNS®

Product Dimensions

Model	L	W	C	D	T
CMP0603	$\frac{1.60 \pm 0.10}{(.063 \pm .004)}$	$\frac{0.80 \pm 0.10}{(.031 \pm .004)}$	$\frac{0.30 \pm 0.20}{(.012 \pm .008)}$	$\frac{0.30 \pm 0.20}{(.012 \pm .008)}$	$\frac{0.45 \pm 0.10}{(.018 \pm .004)}$
CMP0805	$\frac{2.00 \pm 0.10}{(.079 \pm .004)}$	$\frac{1.25 \pm 0.10}{(.049 \pm .004)}$	$\frac{0.40 \pm 0.20}{(.016 \pm .008)}$	$\frac{0.40 \pm 0.20}{(.016 \pm .008)}$	$\frac{0.50 \pm 0.10}{(.020 \pm .004)}$
CMP1206	$\frac{3.10 \pm 0.10}{(.122 \pm .004)}$	$\frac{1.60 \pm 0.10}{(.063 \pm .004)}$	$\frac{0.50 \pm 0.25}{(.020 \pm .010)}$	$\frac{0.50 \pm 0.25}{(.020 \pm .010)}$	$\frac{0.55 \pm 0.10}{(.022 \pm .004)}$
CMP2010	$\frac{5.00 \pm 0.20}{(.197 \pm .008)}$	$\frac{2.50 \pm 0.20}{(.098 \pm .008)}$	$\frac{0.65 \pm 0.25}{(.026 \pm .010)}$	$\frac{0.60 \pm 0.25}{(.023 \pm .010)}$	$\frac{0.60 \pm 0.10}{(.024 \pm .004)}$
CMP2512	$\frac{6.40 \pm 0.20}{(.252 \pm .008)}$	$\frac{3.10 \pm 0.20}{(.122 \pm .008)}$	$\frac{0.60 \pm 0.25}{(.024 \pm .010)}$	$\frac{1.80 \pm 0.25}{(.071 \pm .010)}$	$\frac{0.60 \pm 0.15}{(.024 \pm .006)}$

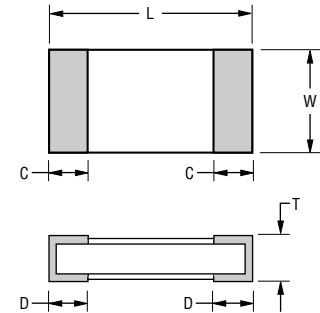

DIMENSIONS: $\frac{\text{MM}}{(\text{INCHES})}$

Recommended Solder Pad Layout

Model	A	B	L
CMP0603	$\frac{0.90}{(.035)}$	$\frac{1.00}{(.039)}$	$\frac{3.00}{(.118)}$
CMP0805	$\frac{1.30}{(.051)}$	$\frac{1.15}{(.045)}$	$\frac{3.50}{(.138)}$
CMP1206	$\frac{1.80}{(.071)}$	$\frac{1.30}{(.051)}$	$\frac{4.70}{(.185)}$
CMP2010	$\frac{3.00}{(.118)}$	$\frac{1.50}{(.059)}$	$\frac{6.80}{(.268)}$
CMP2512	$\frac{3.70}{(.146)}$	$\frac{2.45}{(.096)}$	$\frac{7.60}{(.299)}$

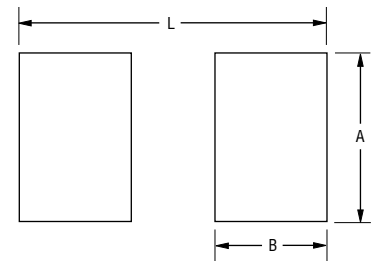

DIMENSIONS: $\frac{\text{MM}}{(\text{INCHES})}$

Surge Performance

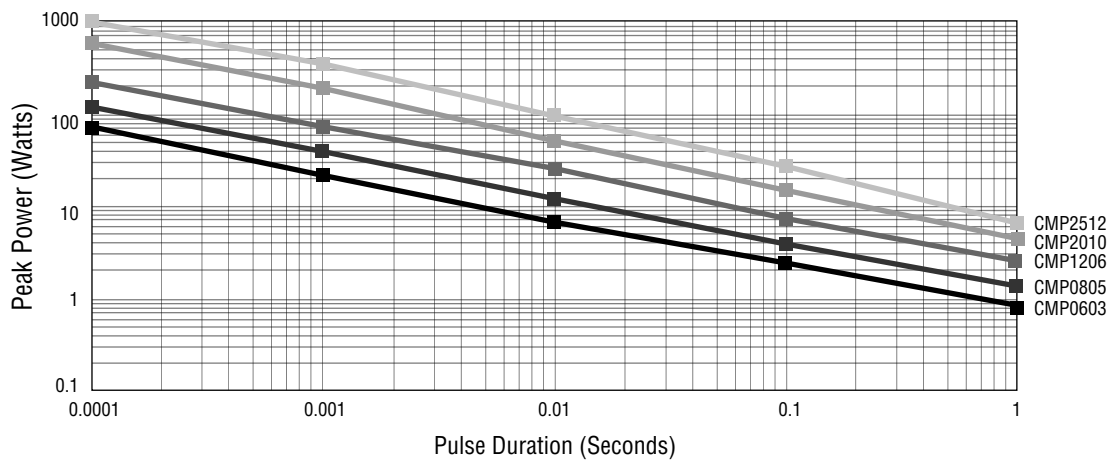

Specifications are subject to change without notice.

Users should verify actual device performance in their specific applications.

The products described herein and this document are subject to specific legal disclaimers as set forth on the last page of this document, and at www.bourns.com/docs/legal/disclaimer.pdf.

CMP Series High Power Anti-Surge Chip Resistors



Construction

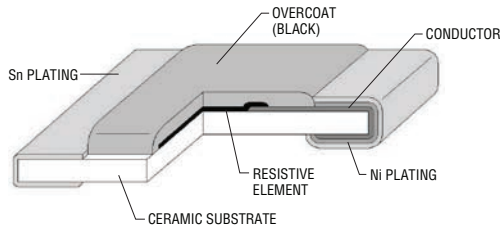

Rated Voltage

The rated voltage is calculated by the following formula:

$$V = \sqrt{P \times R}$$

V: Rated Voltage (V)
P: Rated Power (W)
R: Resistance Value (Ω)

Environmental Characteristics

Moisture Sensitivity Level..... 1

Derating Curve

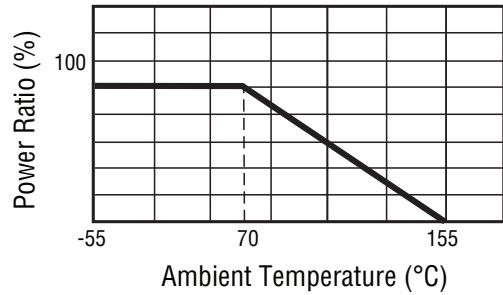

Soldering Profile

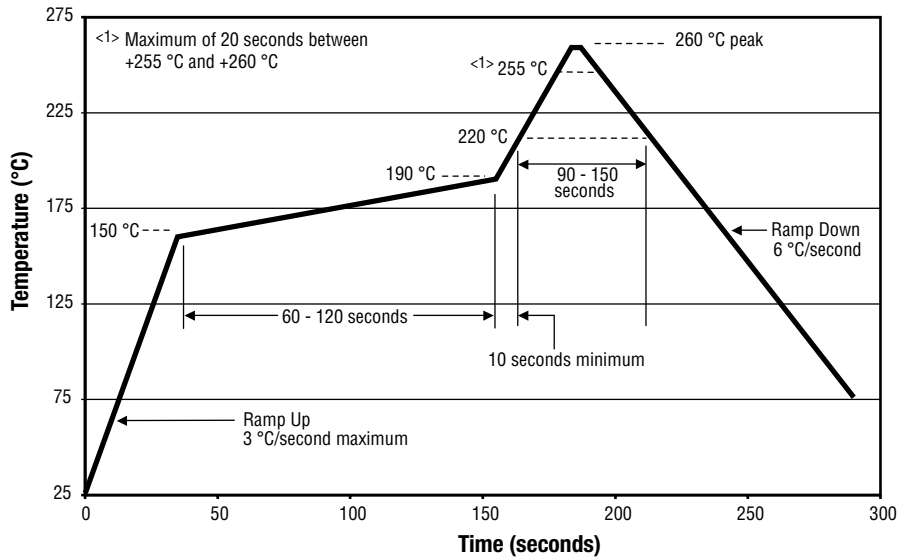

Specifications are subject to change without notice.

Users should verify actual device performance in their specific applications.

The products described herein and this document are subject to specific legal disclaimers as set forth on the last page of this document, and at www.bourns.com/docs/legal/disclaimer.pdf.

CMP Series High Power Anti-Surge Chip Resistors



How to Order

CMP 0603 - F X - 1002 E LF

Model _____
 CMP = High Power Anti-Surge Resistor

Size _____
 0603 = 0603 Size
 0805 = 0805 Size
 1206 = 1206 Size
 2010 = 2010 Size
 2512 = 2512 Size

Resistance Tolerance _____
 F = $\pm 1\%$
 J = $\pm 5\%$

TCR (See Electrical Characteristics chart) _____
 W = ± 200 PPM/ $^{\circ}$ C
 X = ± 100 PPM/ $^{\circ}$ C

Resistance Value _____
1 % Tolerance:
 <100 Ω"R" represents decimal point (example: 24R3 = 24.3 Ω)
 ≥ 100 ΩFirst three digits are significant, fourth digit represents number of zeros to follow
 (example: 8252 = 82.5K Ω)

5 % Tolerance:
 ≥ 10 ΩFirst two digits are significant, third digit represents number of zeros to follow
 (example: 474 = 470K Ω)

Packaging _____
 E = 5,000 pieces on 180 mm (7 inch) plastic reel, paper tape - CMP0603, CMP0805, CMP1206
 4,000 pieces on 180 mm (7 inch) reel, plastic tape - CMP2010, CMP2512

Termination _____
 LF = Tin-plated (RoHS Compliant)

Performance Characteristics

Test	Procedure (IEC 60115-1)	Test Limits ΔR
Short Time Overload	5 times rated power for 5 seconds	1 % Tolerance: $\leq \pm (1\% + 0.05\ \Omega)$ 5 % Tolerance $\leq \pm (2\% + 0.05\ \Omega)$
Temperature Cycling	Repeat 5 cycles as follows: -55 $^{\circ}$ C (30 min.) --> 25 $^{\circ}$ C (2-3 min.)--> 155 $^{\circ}$ C (30 min.) --> 25 $^{\circ}$ C (2~3 min.)	1 % Tolerance $\leq \pm (0.5\% + 0.05\ \Omega)$ 5 % Tolerance $\leq \pm (1\% + 0.05\ \Omega)$
Load Life	1.5 hours at rated voltage followed by a pause of 0.5 hour at 70 \pm 2 $^{\circ}$ C; Cycle repeated for 1000 hours	1 % Tolerance $\leq \pm (1\% + 0.05\ \Omega)$ 5 % Tolerance $\leq \pm (3\% + 0.05\ \Omega)$
Load Life with Humidity	40 \pm 2 $^{\circ}$ C with 90~95 % relative humidity; DC rated voltage for 1.5 hours "ON", 0.5 hour "OFF"; Cycle repeated for 1000 hours	1 % Tolerance $\leq \pm (1\% + 0.05\ \Omega)$ 5 % Tolerance $\leq \pm (3\% + 0.05\ \Omega)$
Resistance to Solder Heat	260 \pm 5 $^{\circ}$ C for 10 \pm 1 seconds	1 % Tolerance $\leq \pm (0.5\% + 0.05\ \Omega)$ 5 % Tolerance $\leq \pm (1\% + 0.05\ \Omega)$
Solderability	After immersing flux, dip in 245 \pm 2 $^{\circ}$ C molten solder bath for 3 \pm 0.5 seconds	At least 95 % of termination must be covered with solder..
Board Flex	Bending 2 mm	1 % Tolerance $\leq \pm (0.5\% + 0.05\ \Omega)$ 5 % Tolerance $\leq \pm (1\% + 0.05\ \Omega)$

Specifications are subject to change without notice.

Users should verify actual device performance in their specific applications.

The products described herein and this document are subject to specific legal disclaimers as set forth on the last page of this document, and at www.bourns.com/docs/legal/disclaimer.pdf.

CMP Series High Power Anti-Surge Chip Resistors

BOURNS®

Typical Part Marking

±5 % (E24): **CMP0603, CMP0805, CMP1206, CMP2010, CMP2512**

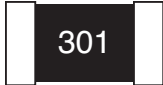

Resistance value is expressed by 3 digits. The first two digits represent the significant figures of the nominal resistance value in ohms; the third digit represents the exponent for a base of 10.

Example: **301** = $30 \times 10^1 = 300 \text{ ohms}$

±1 % (E24/E96): **CMP0805, CMP1206, CMP2010, CMP2512**

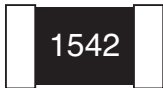

Resistance value is expressed by 4 digits. The first three digits represent the significant figures of the nominal resistance value in ohms; the third digit represents the exponent for a base of 10.

Example: **1542** = $154 \times 10^2 = 15.4K \text{ ohms}$

±1 % (E24): **CMP0603**



Resistance value is expressed by 3 digits. The first two digits represent the significant figures of the nominal resistance value in ohms; the third digit represents the exponent for a base of 10.

Example: **222** = $22 \times 10^2 = 2.2K \text{ ohms}$

±1 % (E96): **CMP0603**



Resistance value is expressed by 2 digits followed by an alpha character multiplier. (Refer to marking table below.)

Example: **01B** = $100 \times 10^1 = 1K \text{ ohms}$

This table shows the first two digits for the three-digit E96 part marking scheme. The third character is a letter multiplier:

A= 10^0
 B= 10^1
 C= 10^2
 D= 10^3
 E= 10^4
 F= 10^5
 G= 10^6
 H= 10^7
 X= 10^{-1}
 Y= 10^{-2}
 Z= 10^{-3}

Code	R Value	Code	R Value	Code	R Value	Code	R Value	Code	R Value
01	100	21	162	41	261	61	422	81	681
02	102	22	165	42	267	62	432	82	698
03	105	23	169	43	274	63	442	83	715
04	107	24	174	44	280	64	453	84	732
05	110	25	178	45	287	65	464	85	750
06	113	26	182	46	294	66	475	86	768
07	115	27	187	47	301	67	487	87	787
08	118	28	191	48	309	68	499	88	806
09	121	29	196	49	316	69	511	89	825
10	124	30	200	50	324	70	523	90	845
11	127	31	205	51	332	71	536	91	866
12	130	32	210	52	340	72	549	92	887
13	133	33	215	53	348	73	562	93	909
14	137	34	221	54	357	74	576	94	931
15	140	35	226	55	365	75	590	95	953
16	143	36	232	56	374	76	604	96	976
17	147	37	237	57	383	77	619		
18	150	38	243	58	392	78	634		
19	154	39	249	59	402	79	649		
20	158	40	255	60	412	80	665		

Specifications are subject to change without notice.

Users should verify actual device performance in their specific applications.

The products described herein and this document are subject to specific legal disclaimers as set forth on the last page of this document, and at www.bourns.com/docs/legal/disclaimer.pdf.

CMP Series High Power Anti-Surge Chip Resistors

BOURNS®

Packaging Dimensions (Conforms to EIA RS-481A)

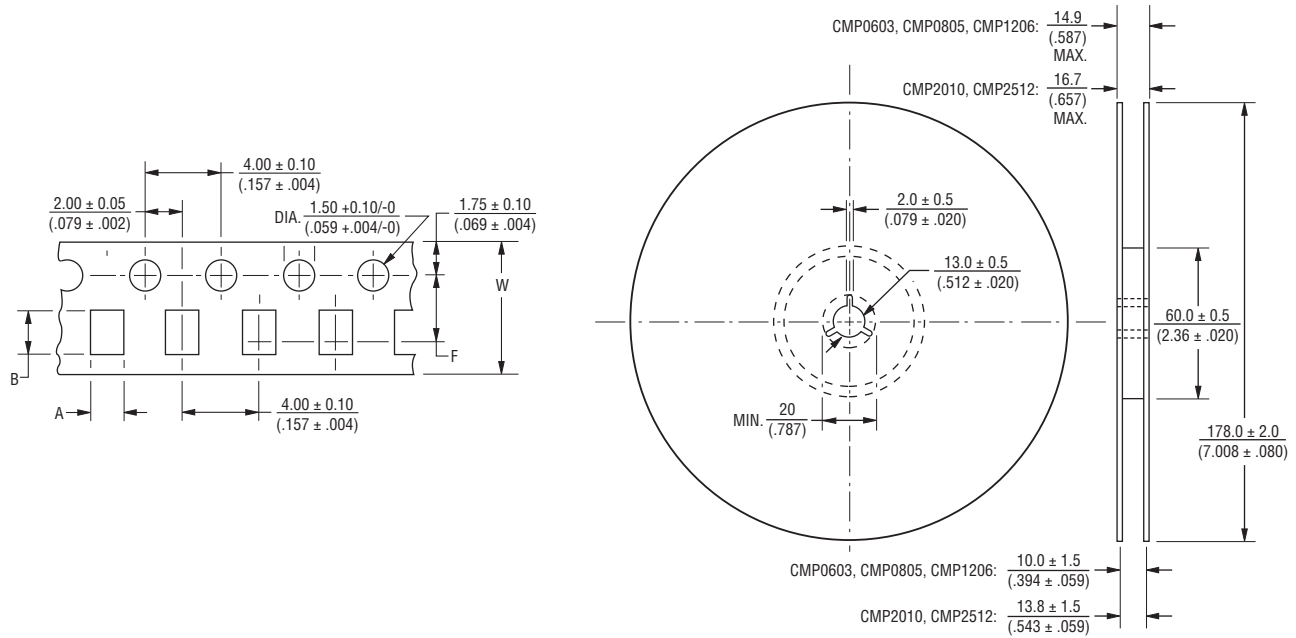

Model	Tape Type	Pieces per Reel	A	B	W	F
CMP0603	Paper	5,000	1.10 ± 0.20 (.043 ± .008)	1.90 ± 0.20 (.075 ± .008)	8.00 ± 0.30 (.315 ± .012)	3.50 ± 0.05 (.138 ± .020)
CMP0805			1.65 ± 0.20 (.065 ± .008)	2.40 ± 0.20 (.094 ± .008)		
CMP1206			2.00 ± 0.20 (.079 ± .008)	3.60 ± 0.20 (.142 ± .008)		
CMP2010	Plastic	4,000	2.80 ± 0.20 (.110 ± .008)	5.50 ± 0.20 (.216 ± .008)	12.00 ± 0.30 (.472 ± .012)	5.50 ± 0.05 (.217 ± .020)
CMP2512			3.50 ± 0.20 (.138 ± .008)	6.70 ± 0.20 (.264 ± .008)		

DIMENSIONS: $\frac{\text{MM}}{\text{(INCHES)}}$

REV. 05/26/20

Specifications are subject to change without notice.

Users should verify actual device performance in their specific applications.

The products described herein and this document are subject to specific legal disclaimers as set forth on the last page of this document, and at www.bourns.com/docs/legal/disclaimer.pdf.

This legal disclaimer applies to purchasers and users of Bourns® products manufactured by or on behalf of Bourns, Inc. and its affiliates (collectively, "Bourns").

Unless otherwise expressly indicated in writing, Bourns® products and data sheets relating thereto are subject to change without notice. Users should check for and obtain the latest relevant information and verify that such information is current and complete before placing orders for Bourns® products.

The characteristics and parameters of a Bourns® product set forth in its data sheet are based on laboratory conditions, and statements regarding the suitability of products for certain types of applications are based on Bourns' knowledge of typical requirements in generic applications. The characteristics and parameters of a Bourns® product in a user application may vary from the data sheet characteristics and parameters due to (i) the combination of the Bourns® product with other components in the user's application, or (ii) the environment of the user application itself. The characteristics and parameters of a Bourns® product also can and do vary in different applications and actual performance may vary over time. Users should always verify the actual performance of the Bourns® product in their specific devices and applications, and make their own independent judgments regarding the amount of additional test margin to design into their device or application to compensate for differences between laboratory and real world conditions.

Unless Bourns has explicitly designated an individual Bourns® product as meeting the requirements of a particular industry standard (e.g., ISO/TS 16949) or a particular qualification (e.g., UL listed or recognized), Bourns is not responsible for any failure of an individual Bourns® product to meet the requirements of such industry standard or particular qualification. Users of Bourns® products are responsible for ensuring compliance with safety-related requirements and standards applicable to their devices or applications.

Bourns® products are not recommended, authorized or intended for use in nuclear, lifesaving, life-critical or life-sustaining applications, nor in any other applications where failure or malfunction may result in personal injury, death, or severe property or environmental damage. Unless expressly and specifically approved in writing by two authorized Bourns representatives on a case-by-case basis, use of any Bourns® products in such unauthorized applications might not be safe and thus is at the user's sole risk. Life-critical applications include devices identified by the U.S. Food and Drug Administration as Class III devices and generally equivalent classifications outside of the United States.

Bourns expressly identifies those Bourns® standard products that are suitable for use in automotive applications on such products' data sheets in the section entitled "Applications." Unless expressly and specifically approved in writing by two authorized Bourns representatives on a case-by-case basis, use of any other Bourns® standard products in an automotive application might not be safe and thus is not recommended, authorized or intended and is at the user's sole risk. If Bourns expressly identifies a sub-category of automotive application in the data sheet for its standard products (such as infotainment or lighting), such identification means that Bourns has reviewed its standard product and has determined that if such Bourns® standard product is considered for potential use in automotive applications, it should only be used in such sub-category of automotive applications. Any reference to Bourns® standard product in the data sheet as compliant with the AEC-Q standard or "automotive grade" does not by itself mean that Bourns has approved such product for use in an automotive application.

Bourns® standard products are not tested to comply with United States Federal Aviation Administration standards generally or any other generally equivalent governmental organization standard applicable to products designed or manufactured for use in aircraft or space applications. Bourns expressly identifies Bourns® standard products that are suitable for use in aircraft or space applications on such products' data sheets in the section entitled "Applications." Unless expressly and specifically approved in writing by two authorized Bourns representatives on a case-by-case basis, use of any other Bourns® standard product in an aircraft or space application might not be safe and thus is not recommended, authorized or intended and is at the user's sole risk.

The use and level of testing applicable to Bourns® custom products shall be negotiated on a case-by-case basis by Bourns and the user for which such Bourns® custom products are specially designed. Absent a written agreement between Bourns and the user regarding the use and level of such testing, the above provisions applicable to Bourns® standard products shall also apply to such Bourns® custom products.

Users shall not sell, transfer, export or re-export any Bourns® products or technology for use in activities which involve the design, development, production, use or stockpiling of nuclear, chemical or biological weapons or missiles, nor shall they use Bourns® products or technology in any facility which engages in activities relating to such devices. The foregoing restrictions apply to all uses and applications that violate national or international prohibitions, including embargos or international regulations. Further, Bourns® products and Bourns technology and technical data may not under any circumstance be exported or re-exported to countries subject to international sanctions or embargoes. Bourns® products may not, without prior authorization from Bourns and/or the U.S. Government, be resold, transferred, or re-exported to any party not eligible to receive U.S. commodities, software, and technical data.

To the maximum extent permitted by applicable law, Bourns disclaims (i) any and all liability for special, punitive, consequential, incidental or indirect damages or lost revenues or lost profits, and (ii) any and all implied warranties, including implied warranties of fitness for particular purpose, non-infringement and merchantability.

For your convenience, copies of this Legal Disclaimer Notice with German, Spanish, Japanese, Traditional Chinese and Simplified Chinese bilingual versions are available at:

Web Page: <http://www.bourns.com/legal/disclaimers-terms-and-policies>

PDF: <http://www.bourns.com/docs/Legal/disclaimer.pdf>



Features

- Thick film technology
- Power rating up to 1.5 watts @ 70 °C
- High power surge withstanding
- RoHS compliant*
- Halogen free**
- AEC-Q200 compliant

Applications

- Power supplies
- Digital meters
- Consumer electronics
- LED lighting
- Industry control boards

CMP-A Series High Power Anti-Surge Chip Resistors

Electrical Characteristics

Characteristic	Model				
	CMP0603A	CMP0805A	CMP1206A	CMP2010A	CMP2512A
Power Rating @ 70 °C	0.25 W	0.5 W	0.75 W	1 W	1.5 W
Operating Temperature Range	-55 °C to +155 °C				
Derated to Zero Load at	+155 °C				
Maximum Working Voltage	75 V	200 V	250 V	200 V	300 V
Maximum Overload Voltage	125 V	300 V	500 V	400 V	600 V
Resistance Tolerance	±1 %, ±5 %				
Temperature Coefficient					
10 Ω to 1 MΩ (±1 %, E24 & E96 Series)	±100 ppm/°C	±100 ppm/°C	±100 ppm/°C	±100 ppm/°C	±100 ppm/°C
10 Ω to 1 MΩ (±5 %, E24 Series)	±200 ppm/°C	±200 ppm/°C	±200 ppm/°C	±200 ppm/°C	±200 ppm/°C

Note: Solder pad and trace size should be evaluated and board surface temperature should not exceed +105 °C when applying full rated power.



Asia-Pacific: Tel: +886-2 2562-4117 • Email: asiacus@bourns.com

EMEA: Tel: +36 88 885 877 • Email: eurocus@bourns.com

The Americas: Tel: +1-951 781-5500 • Email: americus@bourns.com

www.bourns.com



WARNING Cancer and Reproductive Harm - www.P65Warnings.ca.gov

* RoHS Directive 2015/863, Mar 31, 2015 and Annex.

** Bourns considers a product to be "halogen free" if (a) the Bromine (Br) content is 900 ppm or less; (b) the Chlorine (Cl) content is 900 ppm or less; and (c) the total Bromine (Br) and Chlorine (Cl) content is 1500 ppm or less.

Specifications are subject to change without notice.

Users should verify actual device performance in their specific applications.

The products described herein and this document are subject to specific legal disclaimers as set forth on the last page of this document, and at www.bourns.com/docs/legal/disclaimer.pdf.

CMP-A Series High Power Anti-Surge Chip Resistors

BOURNS®

Product Dimensions

Model	L	W	C	D	T
CMP0603A	$\frac{1.60 \pm 0.10}{(.063 \pm .004)}$	$\frac{0.80 \pm 0.10}{(.031 \pm .004)}$	$\frac{0.30 \pm 0.20}{(.012 \pm .008)}$	$\frac{0.30 \pm 0.20}{(.012 \pm .008)}$	$\frac{0.45 \pm 0.10}{(.018 \pm .004)}$
CMP0805A	$\frac{2.00 \pm 0.10}{(.079 \pm .004)}$	$\frac{1.25 \pm 0.10}{(.049 \pm .004)}$	$\frac{0.40 \pm 0.20}{(.016 \pm .008)}$	$\frac{0.40 \pm 0.20}{(.016 \pm .008)}$	$\frac{0.50 \pm 0.10}{(.020 \pm .004)}$
CMP1206A	$\frac{3.10 \pm 0.10}{(.122 \pm .004)}$	$\frac{1.60 \pm 0.10}{(.063 \pm .004)}$	$\frac{0.50 \pm 0.25}{(.020 \pm .010)}$	$\frac{0.50 \pm 0.25}{(.020 \pm .010)}$	$\frac{0.55 \pm 0.10}{(.022 \pm .004)}$
CMP2010A	$\frac{5.00 \pm 0.20}{(.197 \pm .008)}$	$\frac{2.50 \pm 0.20}{(.098 \pm .008)}$	$\frac{0.65 \pm 0.25}{(.026 \pm .010)}$	$\frac{0.60 \pm 0.25}{(.023 \pm .010)}$	$\frac{0.60 \pm 0.10}{(.024 \pm .004)}$
CMP2512A	$\frac{6.40 \pm 0.20}{(.252 \pm .008)}$	$\frac{3.10 \pm 0.20}{(.122 \pm .008)}$	$\frac{0.60 \pm 0.25}{(.024 \pm .010)}$	$\frac{1.80 \pm 0.25}{(.071 \pm .010)}$	$\frac{0.60 \pm 0.15}{(.024 \pm .006)}$

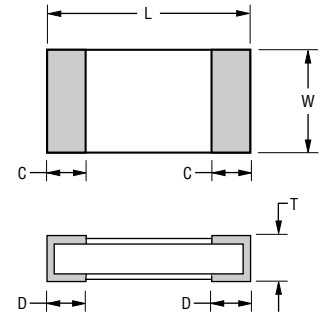

DIMENSIONS: $\frac{\text{MM}}{(\text{INCHES})}$

Recommended Solder Pad Layout

Model	A	B	L
CMP0603A	$\frac{0.90}{(.035)}$	$\frac{1.00}{(.039)}$	$\frac{3.00}{(.118)}$
CMP0805A	$\frac{1.30}{(.051)}$	$\frac{1.15}{(.045)}$	$\frac{3.50}{(.138)}$
CMP1206A	$\frac{1.80}{(.071)}$	$\frac{1.30}{(.051)}$	$\frac{4.70}{(.185)}$
CMP2010A	$\frac{3.00}{(.118)}$	$\frac{1.50}{(.059)}$	$\frac{6.80}{(.268)}$
CMP2512A	$\frac{3.70}{(.146)}$	$\frac{2.45}{(.096)}$	$\frac{7.60}{(.299)}$

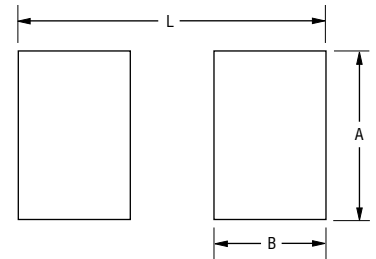

DIMENSIONS: $\frac{\text{MM}}{(\text{INCHES})}$

Surge Performance

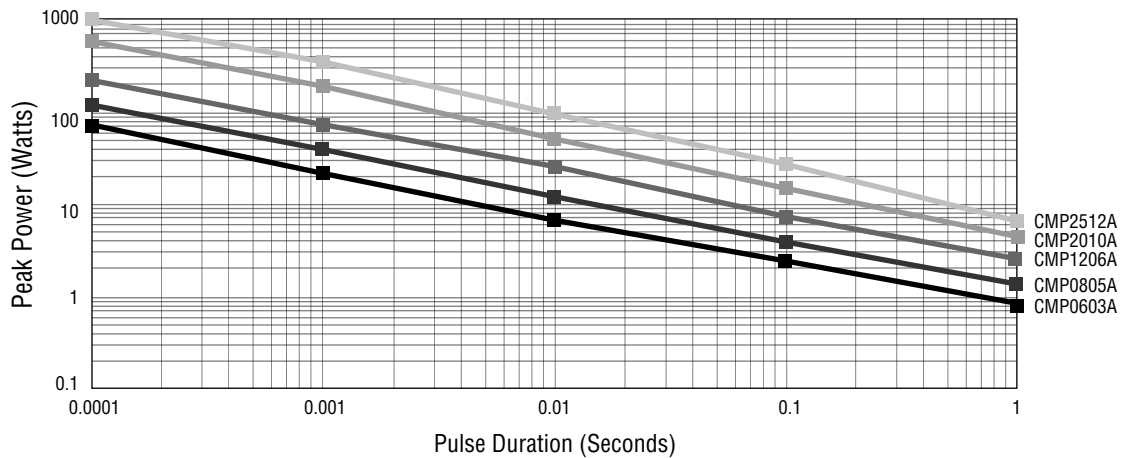

Specifications are subject to change without notice.

Users should verify actual device performance in their specific applications.

The products described herein and this document are subject to specific legal disclaimers as set forth on the last page of this document, and at www.bourns.com/docs/legal/disclaimer.pdf.

CMP-A Series High Power Anti-Surge Chip Resistors



Construction

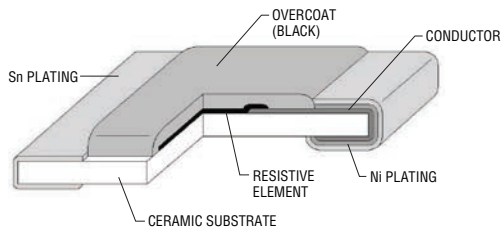

Environmental Characteristics

Moisture Sensitivity Level..... 1

Derating Curve

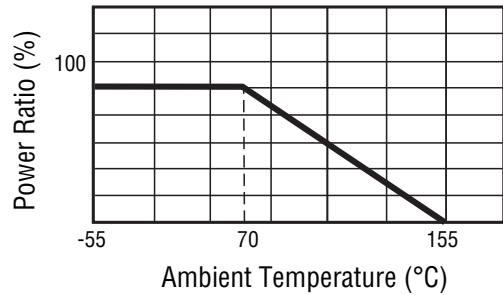

Rated Voltage

The rated voltage is calculated by the following formula:

$$V = \sqrt{P \times R}$$

V: Rated Voltage (V)
P: Rated Power (W)
R: Resistance Value (Ω)

Soldering Profile

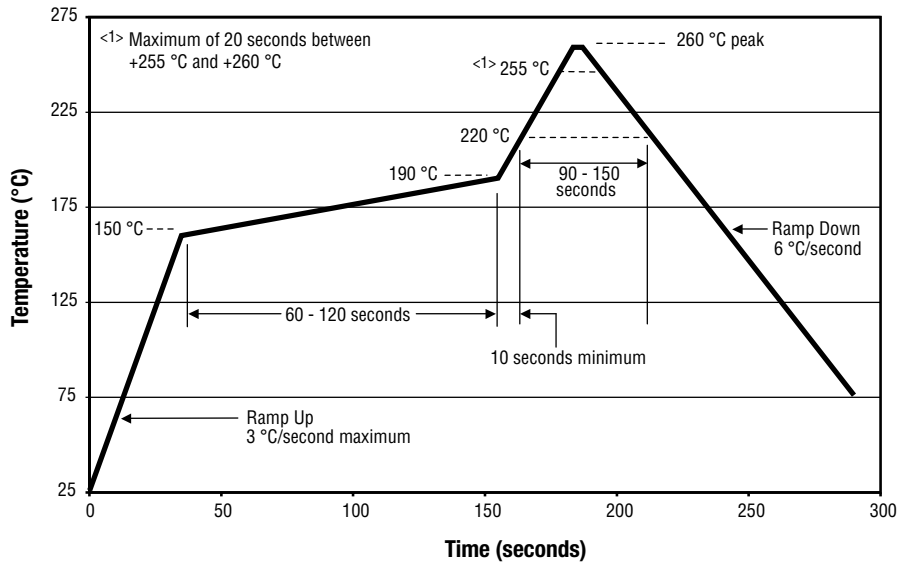

CMP-A Series High Power Anti-Surge Chip Resistors



How to Order

CMP 0603 A F X 1002 E LF

Model	CMP	0603	A	F	X	1002	E	LF
CMP = High Power Anti-Surge Resistor Size 0603 = 0603 Size 0805 = 0805 Size 1206 = 1206 Size 2010 = 2010 Size 2512 = 2512 Size Feature A = AEC-Q200 Compliant Resistance Tolerance F = $\pm 1\%$ J = $\pm 5\%$ TCR (See Electrical Characteristics chart) W = ± 200 PPM/ $^{\circ}$ C X = ± 100 PPM/ $^{\circ}$ C Resistance Value <u>1 % Tolerance:</u> <100 Ω"R" represents decimal point (example: 24R3 = 24.3 Ω) ≥ 100 ΩFirst three digits are significant, fourth digit represents number of zeros to follow (example: 8252 = 82.5K Ω) <u>5 % Tolerance:</u> ≥ 10 ΩFirst two digits are significant, third digit represents number of zeros to follow (example: 474 = 470K Ω) Packaging E = 5,000 pieces on 180 mm (7 inch) plastic reel, paper tape - CMP0603, CMP0805, CMP1206 4,000 pieces on 180 mm (7 inch) reel, plastic tape - CMP2010, CMP2512 Termination LF = Tin-plated (RoHS Compliant)								

CMP-A Series High Power Anti-Surge Chip Resistors

BOURNS®

Performance Characteristics

Test Item	Method	Procedure	Test Limits ΔR
Electrical Characteristics	AEC-Q200 Table 7.1	Measure the resistance value	DC Resistance: F: $\pm 1\%$; J : $\pm 5\%$ TCR: Within the specified
High Temperature Exposure (Storage)	AEC-Q200 Table 7.3	1000 hours @ T = 125 °C unpowered; Measurement at 24 ± 2 hours after test conclusion	J: $\Delta R \leq \pm(3\% + 0.1 \Omega)$ F: $\Delta R \leq \pm(1\% + 0.05 \Omega)$
Temperature Cycling	AEC-Q200 Table 7.4	1000 cycles (-55 °C to +125 °C); Measurement at 24 ± 2 hours after test conclusion	J: $\Delta R \leq \pm(1\% + 0.1 \Omega)$ F: $\Delta R \leq \pm(0.5\% + 0.05 \Omega)$ No mechanical damage
Moisture Resistance	AEC-Q200 Table 7.6	Test 65 °C / 80-100 % RH / 10 cycles; Measurement at 24 ± 2 hours after test conclusion (t = 24 hours/cycle)	J: $\Delta R \leq \pm(1\% + 0.1 \Omega)$ F: $\Delta R \leq \pm(0.5\% + 0.05 \Omega)$
Biased Humidity	AEC-Q200 Table 7.7	1000 hours 85 °C / 85 % RH, 10 % of operating power; Measurement at 24 ± 2 hours after test conclusion	J: $\Delta R \leq \pm(3\% + 0.1 \Omega)$ F: $\Delta R \leq \pm(1\% + 0.05 \Omega)$
Operational Life	AEC-Q200 Table 7.8	Test 1000 hours @ TA = 125 °C at specified rated power; Measurement at 24 ± 2 hours after test conclusion	J: $\Delta R \leq \pm(3\% + 0.1 \Omega)$ F: $\Delta R \leq \pm(1\% + 0.05 \Omega)$
Mechanical Shock	AEC-Q200 Table 7.13	Test peak value: 100 g's, wave: hail-sine; Duration: 6 ms, Velocity: 12.3 ft/sec.	Within product specification tolerance and no visible damage
Vibration	AEC-Q200 Table 7.14	5 g's for 20 min., 12 cycles each of 3 orientations; Test from 10-2000 Hz	J: $\Delta R \leq \pm(1\% + 0.1 \Omega)$ F: $\Delta R \leq \pm(0.5\% + 0.05 \Omega)$ No mechanical damage
Resistance to Solder Heat	AEC-Q200 Table 7.15	Solder dipping @ 270 °C ± 5 °C for 10 sec. ± 1 sec.	J: $\Delta R \leq \pm(1\% + 0.1 \Omega)$ F: $\Delta R \leq \pm(0.5\% + 0.05 \Omega)$ No mechanical damage
Thermal Shock	AEC-Q200 Table 7.16	-55 to 155 °C / dwell time 15 min / max transfer time 20 sec / 300 cycles	J: $\Delta R \leq \pm(1\% + 0.1 \Omega)$ F: $\Delta R \leq \pm(0.5\% + 0.05 \Omega)$ No mechanical damage
ESD	AEC-Q200-002	Test contact min. 1 KV	$\Delta R \leq \pm(1\% + 0.1 \Omega)$
Solderability	AEC-Q200 Table 7.18	a) Baking 155 °C 4H, dipping 235 °C 5 sec b) Steam 8H, dipping 215 °C 5 sec c) Steam 8H, dipping 260 °C 7 sec	Over 95 % of termination must be covered with solder
Flammability	AEC-Q200 Table 7.20	UL-94 V-0 or V-1 are acceptable	Refer UL-94
Board Flex	AEC-Q200 Table 7.21	Bending 2 mm (2512, 1206), 3 mm (0805, 0603)	J: $\Delta R \leq \pm(1\% + 0.1 \Omega)$ F: $\Delta R \leq \pm(0.5\% + 0.05 \Omega)$ No mechanical damage
Terminal Strength	AEC-Q200 Table 7.22	Force 1.8 Kg for 60 sec	No mechanical damage
Sulfur-Resistant	ASTM B-809	+50 °C ± 2 °C, 1000 hours	$\Delta R \leq \pm(1\% + 0.1 \Omega)$

Specifications are subject to change without notice.

Users should verify actual device performance in their specific applications.

The products described herein and this document are subject to specific legal disclaimers as set forth on the last page of this document, and at www.bourns.com/docs/legal/disclaimer.pdf.

CMP-A Series High Power Anti-Surge Chip Resistors

BOURNS®

Typical Part Marking

±5 % (E24):

CMP0603A, CMP0805A, CMP1206A, CMP2010A, CMP2512A

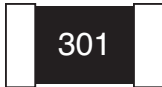

Resistance value is expressed by 3 digits. The first two digits represent the significant figures of the nominal resistance value in ohms; the third digit represents the exponent for a base of 10.

Example: **301** = $30 \times 10^1 = 300 \text{ ohms}$

±1 % (E24/E96):

CMP0805A, CMP1206A, CMP2010A, CMP2512A



Resistance value is expressed by 4 digits. The first three digits represent the significant figures of the nominal resistance value in ohms; the third digit represents the exponent for a base of 10.

Example: **1542** = $154 \times 10^2 = 15.4K \text{ ohms}$

±1 % (E24):

CMP0603A



Resistance value is expressed by 3 digits. The first two digits represent the significant figures of the nominal resistance value in ohms; the third digit represents the exponent for a base of 10.

Example: **222** = $22 \times 10^2 = 2.2K \text{ ohms}$

±1 % (E96):

CMP0603A



Resistance value is expressed by 2 digits followed by an alpha character multiplier. (Refer to marking table below.)

Example: **01B** = $100 \times 10^1 = 1K \text{ ohms}$

This table shows the first two digits for the three-digit E96 part marking scheme. The third character is a letter multiplier:

A= 10^0
 B= 10^1
 C= 10^2
 D= 10^3
 E= 10^4
 F= 10^5
 G= 10^6
 H= 10^7
 X= 10^{-1}
 Y= 10^{-2}
 Z= 10^{-3}

Code	R Value	Code	R Value	Code	R Value	Code	R Value	Code	R Value
01	100	21	162	41	261	61	422	81	681
02	102	22	165	42	267	62	432	82	698
03	105	23	169	43	274	63	442	83	715
04	107	24	174	44	280	64	453	84	732
05	110	25	178	45	287	65	464	85	750
06	113	26	182	46	294	66	475	86	768
07	115	27	187	47	301	67	487	87	787
08	118	28	191	48	309	68	499	88	806
09	121	29	196	49	316	69	511	89	825
10	124	30	200	50	324	70	523	90	845
11	127	31	205	51	332	71	536	91	866
12	130	32	210	52	340	72	549	92	887
13	133	33	215	53	348	73	562	93	909
14	137	34	221	54	357	74	576	94	931
15	140	35	226	55	365	75	590	95	953
16	143	36	232	56	374	76	604	96	976
17	147	37	237	57	383	77	619		
18	150	38	243	58	392	78	634		
19	154	39	249	59	402	79	649		
20	158	40	255	60	412	80	665		

Specifications are subject to change without notice.

Users should verify actual device performance in their specific applications.

The products described herein and this document are subject to specific legal disclaimers as set forth on the last page of this document, and at www.bourns.com/docs/legal/disclaimer.pdf.

CMP-A Series High Power Anti-Surge Chip Resistors

BOURNS®

Packaging Dimensions (Conforms to EIA RS-481A)

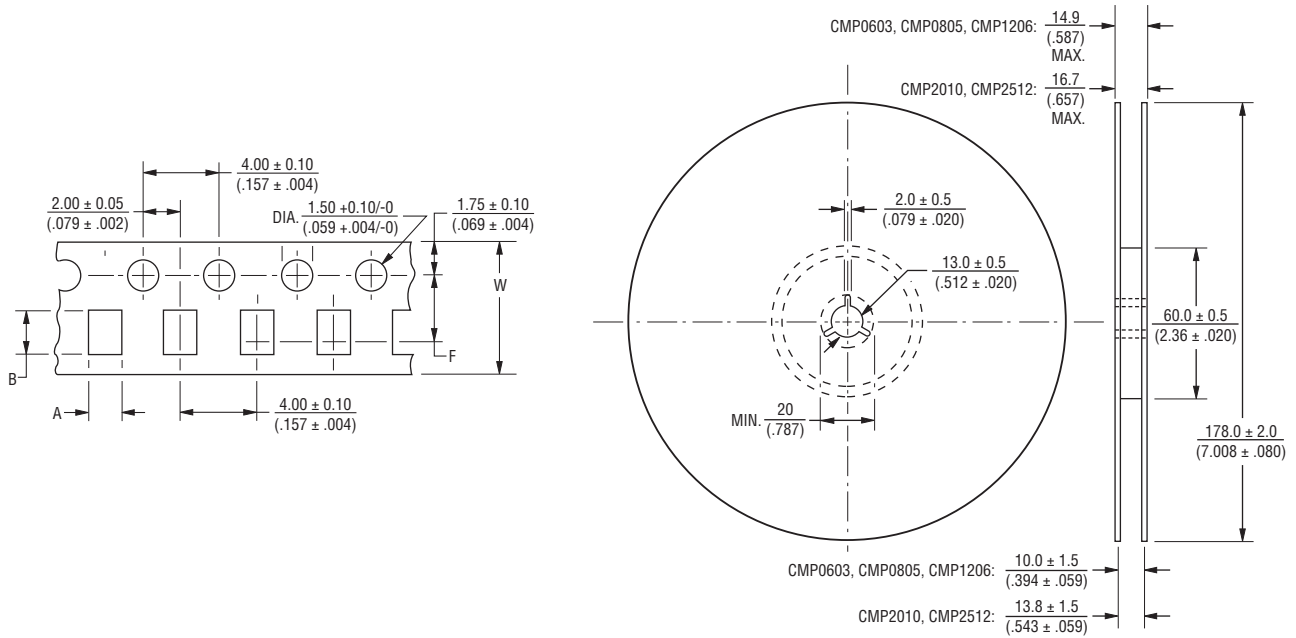

Model	Tape Type	Pieces per Reel	A	B	W	F
CMP0603A	Paper	5,000	$\frac{1.10 \pm 0.20}{(.043 \pm .008)}$	$\frac{1.90 \pm 0.20}{(.075 \pm .008)}$	$\frac{8.00 \pm 0.30}{(.315 \pm .012)}$	$\frac{3.50 \pm 0.05}{(.138 \pm .020)}$
CMP0805A			$\frac{1.65 \pm 0.20}{(.065 \pm .008)}$	$\frac{2.40 \pm 0.20}{(.094 \pm .008)}$		
CMP1206A			$\frac{2.00 \pm 0.20}{(.079 \pm .008)}$	$\frac{3.60 \pm 0.20}{(.142 \pm .008)}$		
CMP2010A	Plastic	4,000	$\frac{2.80 \pm 0.20}{(.110 \pm .008)}$	$\frac{5.50 \pm 0.20}{(.216 \pm .008)}$	$\frac{12.00 \pm 0.30}{(.472 \pm .012)}$	$\frac{5.50 \pm 0.05}{(.217 \pm .020)}$
CMP2512A			$\frac{3.50 \pm 0.20}{(.138 \pm .008)}$	$\frac{6.70 \pm 0.20}{(.264 \pm .008)}$		

DIMENSIONS: $\frac{\text{MM}}{\text{(INCHES)}}$

REV. 05/26/20

Specifications are subject to change without notice.

Users should verify actual device performance in their specific applications.

The products described herein and this document are subject to specific legal disclaimers as set forth on the last page of this document, and at www.bourns.com/docs/legal/disclaimer.pdf.

This legal disclaimer applies to purchasers and users of Bourns® products manufactured by or on behalf of Bourns, Inc. and its affiliates (collectively, "Bourns").

Unless otherwise expressly indicated in writing, Bourns® products and data sheets relating thereto are subject to change without notice. Users should check for and obtain the latest relevant information and verify that such information is current and complete before placing orders for Bourns® products.

The characteristics and parameters of a Bourns® product set forth in its data sheet are based on laboratory conditions, and statements regarding the suitability of products for certain types of applications are based on Bourns' knowledge of typical requirements in generic applications. The characteristics and parameters of a Bourns® product in a user application may vary from the data sheet characteristics and parameters due to (i) the combination of the Bourns® product with other components in the user's application, or (ii) the environment of the user application itself. The characteristics and parameters of a Bourns® product also can and do vary in different applications and actual performance may vary over time. Users should always verify the actual performance of the Bourns® product in their specific devices and applications, and make their own independent judgments regarding the amount of additional test margin to design into their device or application to compensate for differences between laboratory and real world conditions.

Unless Bourns has explicitly designated an individual Bourns® product as meeting the requirements of a particular industry standard (e.g., ISO/TS 16949) or a particular qualification (e.g., UL listed or recognized), Bourns is not responsible for any failure of an individual Bourns® product to meet the requirements of such industry standard or particular qualification. Users of Bourns® products are responsible for ensuring compliance with safety-related requirements and standards applicable to their devices or applications.

Bourns® products are not recommended, authorized or intended for use in nuclear, lifesaving, life-critical or life-sustaining applications, nor in any other applications where failure or malfunction may result in personal injury, death, or severe property or environmental damage. Unless expressly and specifically approved in writing by two authorized Bourns representatives on a case-by-case basis, use of any Bourns® products in such unauthorized applications might not be safe and thus is at the user's sole risk. Life-critical applications include devices identified by the U.S. Food and Drug Administration as Class III devices and generally equivalent classifications outside of the United States.

Bourns expressly identifies those Bourns® standard products that are suitable for use in automotive applications on such products' data sheets in the section entitled "Applications." Unless expressly and specifically approved in writing by two authorized Bourns representatives on a case-by-case basis, use of any other Bourns® standard products in an automotive application might not be safe and thus is not recommended, authorized or intended and is at the user's sole risk. If Bourns expressly identifies a sub-category of automotive application in the data sheet for its standard products (such as infotainment or lighting), such identification means that Bourns has reviewed its standard product and has determined that if such Bourns® standard product is considered for potential use in automotive applications, it should only be used in such sub-category of automotive applications. Any reference to Bourns® standard product in the data sheet as compliant with the AEC-Q standard or "automotive grade" does not by itself mean that Bourns has approved such product for use in an automotive application.

Bourns® standard products are not tested to comply with United States Federal Aviation Administration standards generally or any other generally equivalent governmental organization standard applicable to products designed or manufactured for use in aircraft or space applications. Bourns expressly identifies Bourns® standard products that are suitable for use in aircraft or space applications on such products' data sheets in the section entitled "Applications." Unless expressly and specifically approved in writing by two authorized Bourns representatives on a case-by-case basis, use of any other Bourns® standard product in an aircraft or space application might not be safe and thus is not recommended, authorized or intended and is at the user's sole risk.

The use and level of testing applicable to Bourns® custom products shall be negotiated on a case-by-case basis by Bourns and the user for which such Bourns® custom products are specially designed. Absent a written agreement between Bourns and the user regarding the use and level of such testing, the above provisions applicable to Bourns® standard products shall also apply to such Bourns® custom products.

Users shall not sell, transfer, export or re-export any Bourns® products or technology for use in activities which involve the design, development, production, use or stockpiling of nuclear, chemical or biological weapons or missiles, nor shall they use Bourns® products or technology in any facility which engages in activities relating to such devices. The foregoing restrictions apply to all uses and applications that violate national or international prohibitions, including embargos or international regulations. Further, Bourns® products and Bourns technology and technical data may not under any circumstance be exported or re-exported to countries subject to international sanctions or embargoes. Bourns® products may not, without prior authorization from Bourns and/or the U.S. Government, be resold, transferred, or re-exported to any party not eligible to receive U.S. commodities, software, and technical data.

To the maximum extent permitted by applicable law, Bourns disclaims (i) any and all liability for special, punitive, consequential, incidental or indirect damages or lost revenues or lost profits, and (ii) any and all implied warranties, including implied warranties of fitness for particular purpose, non-infringement and merchantability.

For your convenience, copies of this Legal Disclaimer Notice with German, Spanish, Japanese, Traditional Chinese and Simplified Chinese bilingual versions are available at:

Web Page: <http://www.bourns.com/legal/disclaimers-terms-and-policies>

PDF: <http://www.bourns.com/docs/Legal/disclaimer.pdf>