

# iO2 GAS SENSOR

002708

Issue 2

## Oxygen (O<sub>2</sub>) Intelligent Series Gas Sensor (iseries)



### DOCUMENT PURPOSE

The purpose of this document is to present the performance specification of the intelligent iO2 oxygen gas sensor. This document should be used in conjunction with the Product Safety Datasheet (PSDS 5). For guidance on the safe use of the sensor, please refer to the Communication Protocol (SDCS) and Sensor Mounting Application Note.



### PORTFOLIO

Compact, digital and intelligent gas sensors, iseries sensors are precalibrated, interchangeable and feature digital traceability. These sensors are rated for longer life and are designed to operate in extreme environmental conditions.

Oxygen (O<sub>2</sub>) Sensor: **iO2**

Part Number: AAW85-07WD-CIT

## FEATURES AND BENEFITS



**Digital interface –**  
The sensor has a UART protocol to communicate with the instrument with chip select option as described in the Communication Protocol (SDCS)



**Interchangeable –**  
All intelligent sensors have the same dimensions and communication protocol. All sensors in the range will work with a supply voltage from 3.1 V to 3.3 V



**Digital traceability –**  
Sensors contain the following data: serial number, manufacturing date, and gas type for quick and easy identification of the sensor.



**Pre-calibrated –**  
Sensors will be calibrated during manufacturing and calibration data is written in the sensor. Sensor will output gas concentration when interrogated by instrument



**OEM lock –** Sensors have two levels of lock codes. The first one is an OEM specific code programmed in during manufacture and cannot be modified. This lock code is provided by the OEM. Instrument can check if the sensor has the unique code – if not the instrument can refuse the sensor. The second level of lock code is left blank and can be updated by OEM/Partners during sensor integration into the instrument as needed



**Predictive calibration –** The recalibration alarm will be triggered when the countdown timer is reached



**End-of-life indication –** The alarm will be flagged when the sensor has taken/lost a considerable amount of water (electrolyte concentration is above or below limits)



**Fault indication –** Intelligent sensors can detect several internal faults like drift/fault in reference electrode, electrolyte concentration out of range, counter electrode fault; therefore notifying the user to take corrective actions



**RoHS compliant**

**Five-year life**

**Compact form factor**



**Designed to meet global performance standards**

**ATEX and IEC Ex Certified** per EN IEC 60079-0 and EN IEC 60079-11

**Designed to meet performance standards:** BS EN 50104, ANSI/ISA 92.04.01 and AS/NZS 4641-2007

# INTELLIGENT SERIES GAS SENSORS (iSERIES)

## iO2 SERIES

**TABLE 1. TECHNICAL SPECIFICATIONS**

MEASUREMENT	
<b>Operating Principle</b>	Lead-free electrochemical
<b>Target Gas</b>	O <sub>2</sub>
<b>Range</b>	0% to 25% vol. O <sub>2</sub> - The sensor can read up to 30% O <sub>2</sub>
<b>Accuracy† (over concentration range)</b>	±3% vol. O <sub>2</sub>
<b>T90* Response Time (from air to N<sub>2</sub> 20.9%V/V)</b>	<15 seconds, typ.
<b>T50* Response Time (from air to N<sub>2</sub> 20.9%V/V)</b>	<10 seconds at 20°C
<b>Output</b>	% O <sub>2</sub> (compensated for temperature)
<b>R90 Recovery Time</b>	<45 seconds (for -20°C to 60°C)
<b>R95 Recovery Time</b>	<60 seconds at 20°C
<b>Measurement Interval</b>	1 sample per second (1 Hz)
<b>Resolution</b>	0.1% O <sub>2</sub>
<b>Zero Current (Offset)</b>	After 3 minutes N <sub>2</sub> , <0.6% vol. O <sub>2</sub> equivalent Typically, <0.3% vol. O <sub>2</sub> equivalent
<b>Repeatability*</b>	±5% of measured value
<b>Orientation Sensitivity</b>	<0.2% vol. O <sub>2</sub> equivalent
<b>Warm-up Time</b>	Up to 60 minutes for accurate measurements (see iO2 characterisation note for details)
<b>Serial Communication</b>	UART with Chip Select
ENVIRONMENTAL	
<b>Operating Temperature Range</b>	-40°C to 60°C
<b>Operating Humidity Range</b>	5% RH to 95% RH (non-condensing)
<b>Recommended Storage Temperature</b>	0°C to 20°C
<b>Operating Pressure Range</b>	600 mbar to 1200 mbar
<b>Pressure Coefficient</b>	<0.02% signal/mbar
<b>Thermal Transient</b>	Temp plunge 22°C to -20°C   -20°C to 22°C (No alarm is triggered) <19.5% vol. O <sub>2</sub> , >23.5% vol. O <sub>2</sub>
<b>Pressure Transient</b>	60 cm H <sub>2</sub> O step change <150% signal change
<b>Flow Rate</b>	Typical: 200 ml/min when using recommended gassing hood. (Consult iseries Sensor Mounting Application Note.)
LIFETIME	
<b>Long-Term Output Drift*</b>	<5% signal life over operating life
<b>Expected Operating Life</b>	5 years in air
PHYSICAL CHARACTERISTICS	
<b>Weight</b>	<6 g
<b>Contact Material</b>	Gold plated
<b>O-Ring Material</b>	FKM60 ±5 shore A
<b>Outer Plastic Body Material</b>	Modified PPO

\* Specifications are valid at 20°C, 50% RH, and 1013 mbar using Honeywell recommended circuitry. Performance characteristics outline the performance of sensors supplied within the first three months. Output signal can drift below the lower limit over time.

† For best accuracy, it is recommended that a 'baseline' calibration is performed in clean ambient air when a new sensor has been installed into the instrument.

### Product Dimensions

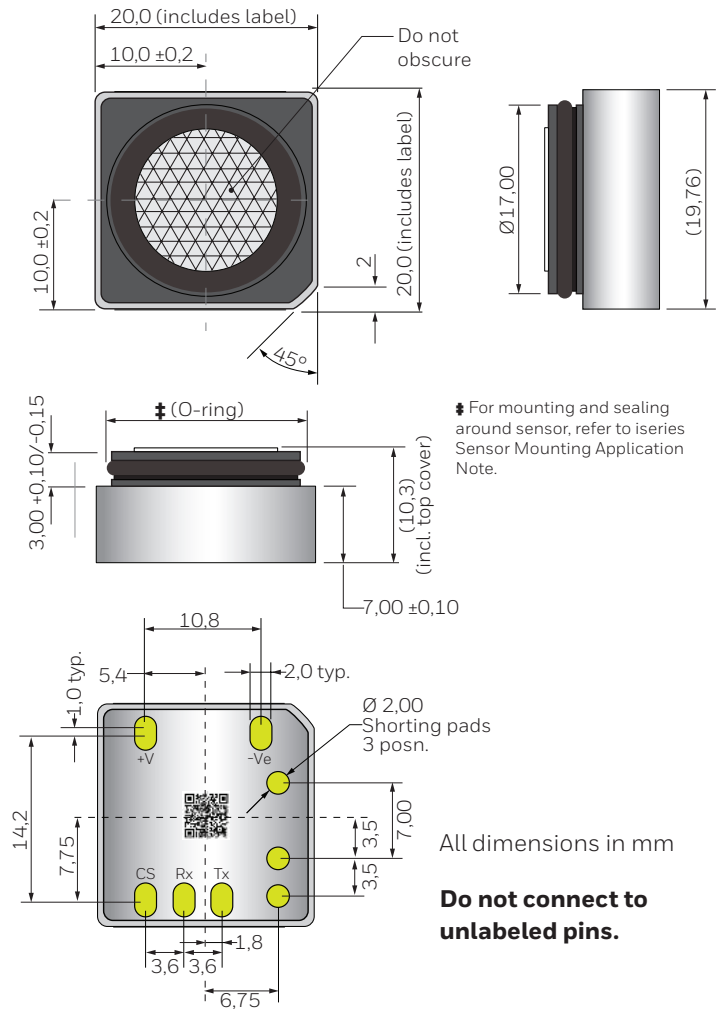

All dimensions in mm  
**Do not connect to unlabeled pins.**

**TABLE 2. ELECTRICAL SPECIFICATIONS**

	Min.	Max.	Typ.	Unit
<b>Supply Voltage (Vdd)</b>	3	3.6	3.3	Vdc
<b>Voltage of any pin relative to ground</b>	0	3.6	-	Vdc
<b>Peak supply current (typ. volt)</b>		25		mA
<b>Current: at stand-by mode</b>	-	-	140.08	µA
<b>Current: at active mode</b>	-	-	146.79	µA
<b>Average power consumption</b>	0.42	90	0.48	mW

For compatibility with the whole iseries range, the supply voltage should be between 3.1 V and 3.3 V.

**TABLE 3. PINOUT**

Pin	Description
<b>+V</b>	Positive power supply
<b>-V</b>	Ground
<b>Rx</b>	Data transmitted from instrument to sensor
<b>Tx</b>	Data transmitted from sensor to instrument
<b>CS</b>	Chip Select
<b>Other Pads</b>	Do not connect, shorting link contacts only

**NOTE:** Oxygen cells are shipped with a shorting clip which must be removed prior to installation.

# INTELLIGENT SERIES GAS SENSORS (iSERIES)

## iO2 SERIES

TABLE 4. iO2 PARAMETERS

iO <sub>2</sub> parameters		Default Values	Configurable Range	Customisable: Implemented by Honeywell (Non-configurable through the communication protocol)	Configurable: The parameter can be changed through the communication protocol by users	Notes
OEM Lock	OEM code (First layer)	Password is customisable.* (NoLock will be set by default in case the OEM lock is not required)	No more than 6 characters (ASCII format)	✓		* OEM code will be set by Honeywell during sensor manufacturing. Code to be provided by OEM
	Partner code (Second layer)	–	No more than 6 characters (ASCII format)		✓	Once this code has been set by user, it is not possible to change it.
User Factor		User factor 0: 100 User factor 1: 100 UF 2-3: Reserved UF 4-9: Customisable ----- User factors can be added to include auto-compensation for using different membranes or instruments	10 allocated slots ----- 2 user factors are already implemented (no additional membrane and with recommended membrane), 2 are reserved and the remaining 6 can be customised	✓*	✓**	* User factor 0 and 1 programmed into the sensor during manufacturing. Additional User Factors can be added to the selectable list during the manufacturing process. This user factor has to be provided by the user. ** Users can select the desired user factor from the selectable list
Calibration	Zero (fresh air)	20.9% O <sub>2</sub>			✓	Calibration is performed at two points throughout the operating range of the sensor. The calibration points are defined by the zero and span values. The zero value represent the response of the sensor in clean air (20.9 % O <sub>2</sub> )
	Span	0% O <sub>2</sub>			✗	Span is the calibration point that is done in the absence of oxygen (i.e. N <sub>2</sub> )
Alarms	Low	19.5% O <sub>2</sub>	Limit LOW lower: 0.5 Limit LOW upper: 25		✓	Indicates a concentration level below clean air
	High	23.5% O <sub>2</sub>	Limit HIGH lower: 0.5 Limit HIGH upper: 25		✓	Indicates a concentration level above clean air
Predictive calibration	Countdown timer (Cal due days)	180 days			✓	The recalibration alarm will be triggered when the countdown timer is reached
End of Life	<b>The EoL alarm will be triggered when the countdown or the future prediction conditions are met</b>					
	Future prediction algorithm				✗	The alarm is triggered when the sensor is too dry or too wet (electrolyte concentration is above or below limits)
	Countdown timer	1825 days			✗	The countdown timer is set for 1825 days, i.e. 5 years
Deadband	Active by default	✓			✓	With the deadband enabled the sensor will not read changes until the concentration reaches the deadband value. Is normally used to prevent measurement oscillations. The baseline of the deadband is 20.9 % O <sub>2</sub> (the reference is ambient air). This function can be configured to different limits
	Incoming	0.1% O <sub>2</sub>	Whole measurement range		✓	Consult iseries appendix 1 (technical communication) section 4.2 for information about these parameters
	Outgoing	0.3% O <sub>2</sub>	Incoming ≤ Outgoing		✓	
Bump Due Days		1 day			✓	A bump test is a brief exposure of the sensor to the target gas. The test has the objective of verifying that the sensor responds and the instrument acts accordingly. The sensor will tell the user when the bump interval has been exceeded

# INTELLIGENT SERIES GAS SENSORS (iSERIES)

## iO2 SERIES

**TABLE 5. INTRINSIC SAFETY CERTIFICATIONS**

Intrinsic Safety	
<b>Entity Parameters</b>	Ui = 5.88 V, Ii = 1.1 A, Pi = 1.2 W, Ci = 13.14 uF, Li = 0 uH
<b>Intrinsic Safety Rating</b>	IIC T4, ia, 60°C
<b>ATEX Marking</b>	 I M1 II 1G Ex ia I Ma Ex ia IIC Ga

### Poisoning

Gas sensors are designed for operation in a wide range of environments and harsh conditions. However, it is important that exposure to high concentrations of solvent vapours is avoided, both during storage, fitting into instruments, and operation. When using sensors with printed circuit boards (PCBs), degreasing agents should be used before the sensor is fitted.

Do not glue directly on or near the sensor as the solvent may cause crazing of the plastic.

## WARRANTY/REMEDY

Honeywell warrants goods of its manufacture as being free of defective materials and faulty workmanship during the applicable warranty period. Honeywell's standard product warranty applies unless agreed to otherwise by Honeywell in writing; please refer to your order acknowledgment or consult your local sales office for specific warranty details. If warranted goods are returned to Honeywell during the period of coverage, Honeywell will repair or replace, at its option, without charge those items that Honeywell, in its sole discretion, finds defective. **The foregoing is buyer's sole remedy and is in lieu of all other warranties, expressed or implied, including those of merchantability and fitness for a particular purpose. In no event shall Honeywell be liable for consequential, special, or indirect damages.**

While Honeywell may provide application assistance personally, through our literature and the Honeywell web site, it is buyer's sole responsibility to determine the suitability of the product in the application.

Specifications may change without notice. The information we supply is believed to be accurate and reliable as of this writing. However, Honeywell assumes no responsibility for its use.

## FOR MORE INFORMATION

Honeywell Advanced Sensing Technologies services its customers through a worldwide network of sales offices and distributors. For application assistance, current specifications, pricing, or the nearest Authorized Distributor, visit [sps.honeywell.com/ast](https://sps.honeywell.com/ast) or call:

USA/Canada	+302 613 4491
Latin America	+1 305 805 8188
Europe	+44 1344 238258
Japan	+81 (0) 3-6730-7152
Singapore	+65 6355 2828
Greater China	+86 4006396841

### Honeywell

#### Advanced Sensing Technologies

830 East Arapaho Road  
Richardson, TX 75081  
[sps.honeywell.com/ast](https://sps.honeywell.com/ast)

## WARNING MISUSE OF DOCUMENTATION

- The information presented in this product sheet is for reference only. Do not use this document as a product installation guide.
- Complete installation, operation, and maintenance information is provided in the instructions supplied with each product.

**Failure to comply with these instructions could result in death or serious injury.**

## SAFETY NOTE

This sensor is designed to be used in safety-critical applications. To ensure that the sensor and/or instrument in which it is used, are operating properly, it is a requirement that the function of the device is confirmed by exposure to target gas (bump check) before each use of the sensor and/or instrument. Failure to carry out such tests may jeopardize the safety of people and property.

Under no circumstances should intelligent sensor pads be soldered to, as this can cause leakage of electrolyte. Connection should be made via a mounting socket and spring connector.

**WARNING: SOLDERING TO PADS WILL RENDER YOUR WARRANTY VOID.**