



Features

- Separate 9A peak source and sink outputs
- Operating Voltage Range: -10V to +25V
- Internal negative charge pump regulator for selectable negative gate drive bias
- Desaturation detection with soft shutdown sink driver
- TTL and CMOS compatible input
- Under Voltage lockout (UVLO)
- Thermal shutdown
- Open drain FAULT output

Applications

- Driving SiC MOSFETs and IGBTs
- On-board charger and DC charging station
- Industrial inverters
- PFC, AC/DC and DC/DC converters

IX4351 Functional Block Diagram

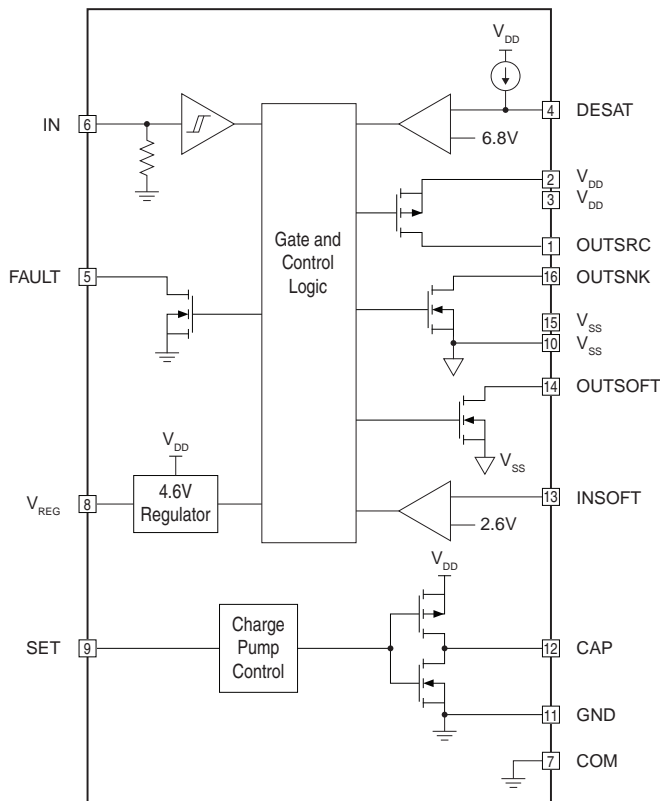

Description

The IX4351NE is designed specifically to drive SiC MOSFETs and high power IGBTs. Separate 9A source and sink outputs allow for tailored turn-on and turn-off timing while minimizing switching losses. An internal negative charge regulator provides a selectable negative gate drive bias for improved dV/dt immunity and faster turn-off.

Desaturation detection circuitry detects an over current condition of the SiC MOSFET and initiates a soft turn off, thus preventing a potentially damaging dV/dt event. The logic input is TTL and CMOS compatible; this input does not need to be level shifted even with a negative gate drive bias voltage. Protection features include UVLO and thermal shutdown detection. An open drain FAULT output signals a fault condition to the microcontroller.

The IX4351NE is rated for operational temperature range of -40°C to +125°C, and is available in a thermally enhanced 16-pin power SOIC package.

Ordering Information

Part	Description
IX4351NE	16-Pin power SOIC with exposed thermal pad. In tubes (50/Tube)
IX4351NETR	16-Pin power SOIC with exposed thermal pad. In Tape & Reel (2000/Reel)



1. Specifications	3
1.1 Package Pinout: 16-Pin SOIC Package	3
1.2 Pin Description: 16-Pin SOIC Package	3
1.3 Absolute Maximum Ratings (With respect to V_{COM} unless otherwise specified)	4
1.4 Recommended Operating Conditions	4
1.5 Electrical Characteristics	4
1.6 Thermal Characteristics	6
2. Functional Description	7
2.1 Logic Input (IN)	7
2.2 Gate Drive Outputs (OUTSRC and OUTSNK)	7
2.3 4.6 Volt Regulator (VREG)	7
2.4 Negative V_{SS} Charge Pump Regulator	8
2.5 Desaturation Detection and Protection	8
2.6 Thermal Shutdown	8
2.7 FAULT Output	8
3. Manufacturing Information	9
3.1 Moisture Sensitivity	9
3.2 ESD Sensitivity	9
3.3 Soldering Profile	9
3.4 Board Wash	9
3.5 Mechanical Dimensions	10

1 Specifications

1.1 Package Pinout: 16-Pin SOIC Package

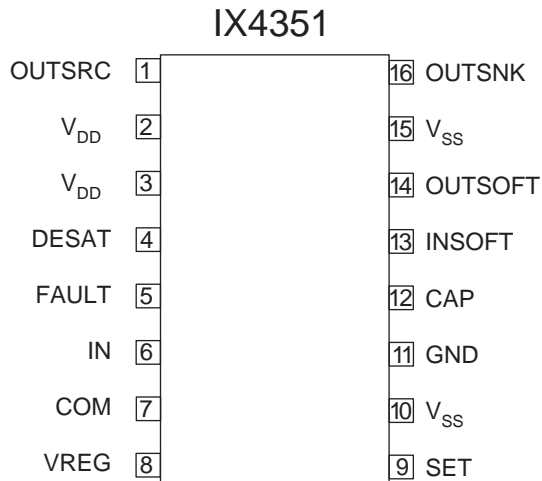

1.2 Pin Description: 16-Pin SOIC Package

Pin#	Name	Description
1	OUTSRC	Gate driver source output
2	V _{DD}	Positive supply voltage for gate driver outputs and logic circuitry
3	V _{DD}	Positive supply voltage for gate driver outputs and logic circuitry
4	DESAT	Sense input for the desaturation detection comparator
5	FAULT	Open-Drain Fault status output
6	IN	Logic input
7	COM	Common ground connection
8	VREG	4.6V regulator output
9	SET	Negative bias voltage set input
10	V _{SS}	Negative drive voltage supply
11	GND	Charge pump ground connection
12	CAP	Flying charge pump capacitor connection
13	INSOFT	Soft shutdown comparator input
14	OUTSOFT	Soft shutdown sink driver output
15	V _{SS}	Negative drive voltage supply
16	OUTSNK	Gate driver sink output

1.3 Absolute Maximum Ratings (With respect to V_{COM} unless otherwise specified)

Parameter	Symbol	Minimum	Maximum	Units
Positive Supply Voltage	V_{DD}	-0.3	32	V
Negative Supply Voltage	V_{SS}	-10	0	V
Supply Voltage Range	$V_{DD} - V_{SS}$	-0.3	40	V
Gate Drive Output Voltages	$V_{OUTSRC}, V_{OUTSNK}, V_{OUTSOFT}$	$V_{SS} - 0.3$	$V_{DD} + 0.3$	V
Gate Drive Output Current	I_{OUTSRC}, I_{OUTSNK}	-	± 9	A
Logic Input Voltage	V_{IN}	-0.3	7	V
DESAT Input Voltage	V_{DESAT}	-0.3	$V_{DD} + 0.3$	V
SET Input Voltage	V_{SET}	$V_{COM} - 1$	$V_{COM} + 7$	V
FAULT Output Voltage	V_{FAULT}	-0.3	$V_{DD} + 0.3$	V
VREG Output Voltage	V_{REG}	-0.3	7	V
Junction Temperature	T_J	-55	+150	$^{\circ}\text{C}$
Storage Temperature	T_{STG}	-55	+150	$^{\circ}\text{C}$

1.4 Recommended Operating Conditions

Parameter	Symbol	Minimum	Maximum	Units
Positive Supply Voltage	V_{DD}	13	25	V
Negative Supply Voltage	V_{SS}	-10	0	V
Input Voltage	V_{IN}	0	5.5	V
Operating Ambient Temperature	T_A	-40	125	$^{\circ}\text{C}$

1.5 Electrical Characteristics

($V_{DD}=20\text{V}$, $V_{SS}=-5\text{V}$, $COM=GND=0\text{V}$, $C_{DD}=C_{REG}=4.7\mu\text{F}$, $C_{SS}=10\mu\text{F}$, $T_A=-40^{\circ}\text{C}$ to $+125^{\circ}\text{C}$, unless otherwise specified.)

1.5.1 V_{DD} Section

Parameter	Conditions	Symbol	Minimum	Typical	Maximum	Units
Operating V_{DD} Supply Current	$f_{IN}=100\text{kHz}$, $C_{LOAD}=2.2\text{nF}$	I_{DD}	-	19	28	mA
Quiescent V_{DD} Supply Current	No load	I_{DDQ}	-	2.9	4.4	mA
V_{DD} UVLO Rising Threshold	-	V_{DDUV+}	10	12	13	V
V_{DD} UVLO Hysteresis	-	V_{DDHYS}	-	2	-	V

1.5.2 V_{REG} Section

Parameter	Conditions	Symbol	Minimum	Typical	Maximum	Units
Regulator Output Voltage	$I_{VREG}=-5\text{mA}$	V_{VREG}	4.2	4.6	5	V
Line Regulation	$15\text{V} < V_{DD} < 25\text{V}$, $I_{VREG}=-5\text{mA}$	ΔV_{VREG}	-	0.1	0.2	V
Load Regulation	$I_{REG}=-1\text{mA}$ to -10mA		-	0.1	0.4	V

1.5.3 Charge Pump Section

Parameter	Conditions	Symbol	Minimum	Typical	Maximum	Units
Negative Bias Rail Voltage Range	-	V_{SS}	-8	$-V_{DD}$	-3.5	V
Maximum V_{SS} Current	$C_{FLY}=66nF, R_{FLY}=33\Omega$	I_{SS}	-	-	50	mA
Charge Pump Frequency	-	f_{OSC}	90	124	160	kHz

1.5.4 Desaturation Section

Parameter	Conditions	Symbol	Minimum	Typical	Maximum	Units
DESAT Source Current	$V_{DESAT}=0V$	I_{DESAT}	400	570	750	μA
DESAT Threshold Voltage	-	$V_{TH,DESAT}$	6	6.8	8	V
Blanking Time	-	t_{BLANK}	-	250	-	ns
DESAT Pull Down Resistance	-	R_{DESAT}	-	900	-	Ω

1.5.5 Thermal Shutdown Section

Parameter	Conditions	Symbol	Minimum	Typical	Maximum	Units
Thermal Shutdown Temperature	-	TSD	-	160	-	$^{\circ}C$
Thermal Shutdown Hysteresis	-	TSD_{HYS}	-	20	-	$^{\circ}C$

1.5.6 Logic Input Section

Parameter	Conditions	Symbol	Minimum	Typical	Maximum	Units
High Level Input Voltage	-	V_{INH}	2.2	-	-	V
Low Level Input Voltage	-	V_{INL}	-	-	1	V
Input Hysteresis	-	V_{INHYS}	0.2	0.4	-	V
High Level Input Current	$V_{IN}=5v$	I_{INH}	-	-	70	μA
Low Level Input Current	$V_{IN}=0V$	I_{INL}	-	-	-10	μA
Input Pull-Down Resistance	-	R_{IN}	-	100	-	k Ω

1.5.7 FAULT Section

Parameter	Conditions	Symbol	Minimum	Typical	Maximum	Units
Output Low Voltage	$I_{FAULT}=20mA$	V_{FAULTL}	-	-	0.8	V
Output Leakage Current	$V_{FAULT}=25V$	I_{FAULT}	-	0.1	10	μA
DESAT Detect to FAULT Delay	-	$t_{FAULTDLY}$	-	150	-	ns

1.5.8 Soft Shutdown Section

Parameter	Conditions	Symbol	Minimum	Typical	Maximum	Units
Soft Shutdown Threshold Voltage	-	$V_{TH,INSOFT}$	2.3	2.6	3	V
Soft Shutdown Hysteresis	-	$V_{INSOFTHYS}$	-	0.4	-	V
OUTSOFT Peak Sink Current	-	$I_{OUTSOFT}$	-	900	-	mA
OUTSOFT On Resistance	$I_{OUTSOFT}=100mA$	$R_{OUTSOFT}$	-	7	15	Ω
DESAT Detect to OUTSOFT Delay	-	$t_{OUTSOFTDLY}$	-	125	-	ns

1.5.9 Gate Driver Section

Parameter	Conditions	Symbol	Minimum	Typical	Maximum	Units
High Level Output Voltage	$I_{OUTSRC}=-100mA$	V_{OUTSRC}	$V_{DD}-0.25$	-	-	V
Low Level Output Voltage	$I_{OUTSNK}=100mA$	V_{OUTSNK}	-	-	0.25	V
OUTSRC ON-Resistance	$I_{OUTSRC}=-100mA$	R_{OUTSRC}	-	0.8	2	Ω
OUTSNK ON-Resistance	$I_{OUTSNK}=100mA$	R_{OUTSNK}	-	0.7	1.5	Ω
Turn-On Propagation Delay Time	$C_{LOAD}=10nF$	t_{ON}	-	70	125	ns
Turn-Off Propagation Delay Time	$C_{LOAD}=10nF$	t_{OFF}	-	65	125	ns
Turn-On Rise Time	$C_{LOAD}=1nF$	t_R	-	10	20	ns
Turn-Off Fall Time	$C_{LOAD}=1nF$	t_F	-	10	20	ns

1.6 Thermal Characteristics

Parameter	Symbol	Rating	Units
Thermal Impedance, Junction to Ambient	θ_{JA}	60	$^{\circ}C/W$
Thermal Impedance, Junction to Case	θ_{JC}	28	$^{\circ}C/W$

2 Functional Description

The IX4351NE is designed to provide the gate drive for high power SiC MOSFETs and IGBTs.

Figure 1. IX4351NE Typical Application Circuit

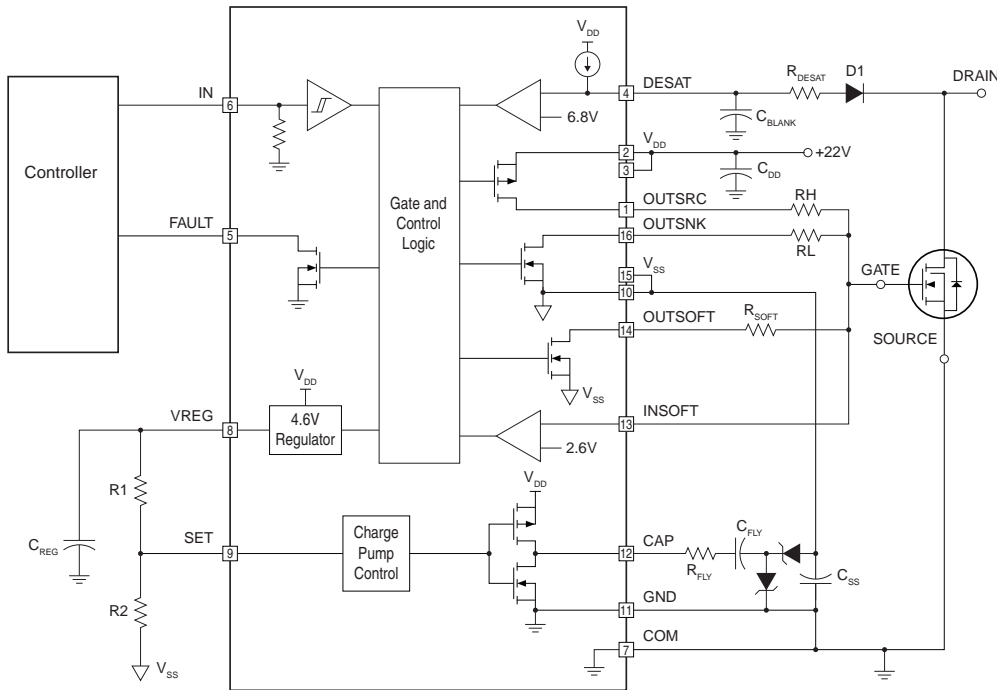

2.1 Logic Input (IN)

The logic input IN controls the state of the high current source driver output (OUTSRC), high current sink driver output (OUTSNK), and a lower current sink driver output (OUTSOFT). The IN input is a high-speed Schmitt trigger buffer with 0.4V hysteresis. The IN logic thresholds are TTL and CMOS compatible, and are referenced to COM. When V_{DD} is greater than the V_{DD} UVLO rising threshold (V_{DDUV+} typically 12V) IN controls the state of the gate driver outputs according to Table 1:

2.1.1 Table 1

IN	V_{DD}	OUTSRC	OUTSNK	OUTSOFT
X	$< V_{DDUV+}$	Off	Low	Low
0	$> V_{DDUV+}$	Off	Low	Low
1	$> V_{DDUV+}$	High	Off	Off

2.2 Gate Drive Outputs (OUTSRC and OUTSNK)

The IX4351NE power outputs are rated for 9A peak current capability. Separate source and sink outputs allow independent adjustment of the discrete SiC MOSFET or IGBT turn-on and turn-off transactions with a single resistor. An internal dead time prevents the cross conduction of the source and sink outputs.

2.3 4.6 Volt Regulator (VREG)

The internal 4.6V regulator provides power for the low voltage control circuitry. An external 4.7 μ F bypass capacitor (C_{REG}) is required. VREG can source up to 10mA, and can be used to set the negative bias voltage and power an external logic optocoupler.

2.4 Negative V_{SS} Charge Pump Regulator

The IX4351NE has an inverting charge pump regulator that produces a negative regulated V_{SS} output. The charge pump operates in a closed-loop mode creating V_{SS} from V_{DD}. The charge pump output regulation is achieved by sensing the V_{SS} voltage through resistor divider R1 and R2. The charge pump requires an external flying capacitor (C_{FLY}), two discrete Schottky diodes, a storage capacitor (C_{SS}), and a peak current limiting resistor (R_{FLY}). V_{SS} is set by the R1 and R2 resistor divider:

$$V_{SS} = -V_{REG} \cdot \left(\frac{R2}{R1}\right)$$

2.5 Desaturation Detection and Protection

The desaturation protection circuit ensures the protection of the external SiC MOSFET or IGBT in the event of an over-current situation. The DESAT pin monitors the drain voltage of the power SiC MOSFET or the collector of the power IGBT via R_{DESAT} and D1. If the drain or collector voltage exceed the DESAT Threshold Voltage (V_{TH,DESAT} typically 6.8V) a controlled turn-off sequence is initiated. OUTSRC is turned off and OUTSOFT is turned on. The 900mA sink capability of OUTSOFT allows an initial slow turn-off of the external SiC MOSFET or IGBT. When

the GATE voltage decreases to the Soft Shutdown Threshold Voltage (V_{TH,INSOFT} typically 2.6V) OUTSNK turns on and quickly pulls the GATE to V_{SS}. This two-step turn-off avoids dangerous dV/dt over-voltages across the external SiC MOSFET or IGBT.

The DESAT comparator is disabled for a fixed blanking time (t_{BLANK}) to avoid detecting a false desaturation event during the external SiC MOSFET or IGBT turn-on. The nominal t_{BLANK} is 250ns, which can be increased by adjusting R_{DESAT} and C_{BLANK}. This blanking time starts when IN transitions from low to high.

2.6 Thermal Shutdown

Thermal protection circuitry turns off OUTSRC and turns on OUTSNK and OUTSOFT when the junction temperature reaches +160°C. OUTSRC is re-enabled when the junction temperature cools to +140°C.

2.7 FAULT Output

The FAULT output signals if the IX4351NE is undergoing a fault condition. The open-drain NMOS is pulled low when V_{DD} < V_{DDUV+}, T_J=TSD, or a desaturation is detected. FAULT is turned off when the fault condition is remedied.

Figure 2. Timing Diagram

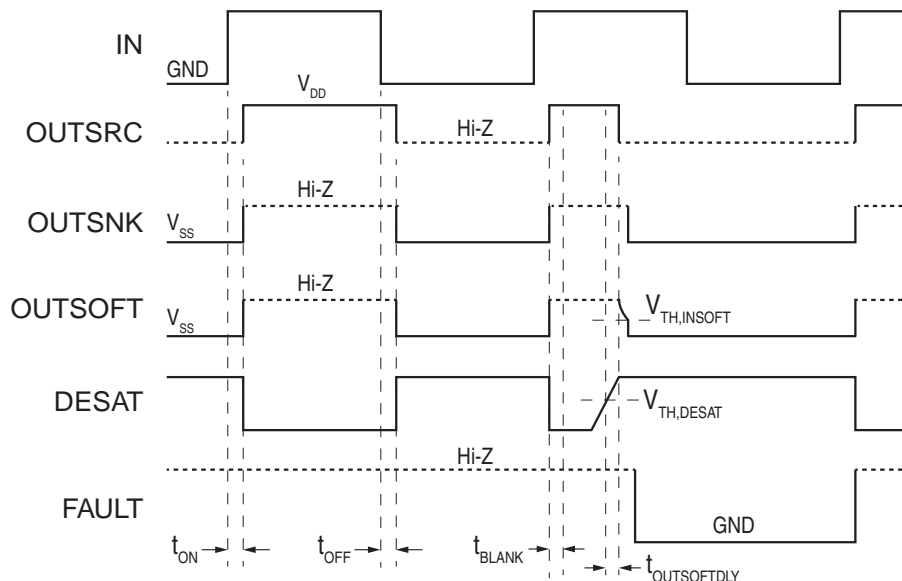

3 Manufacturing Information

3.1 Moisture Sensitivity



All plastic encapsulated semiconductor packages are susceptible to moisture ingress. IXYS Integrated Circuits classifies its plastic encapsulated devices for moisture sensitivity according to the latest version of the joint industry standard, **IPC/JEDEC J-STD-020**, in force at the time of product evaluation. We test all of our products to the maximum conditions set forth in the standard, and guarantee proper operation of our devices when handled according to the limitations and information in that standard as well as to any limitations set forth in the information or standards referenced below.

Failure to adhere to the warnings or limitations as established by the listed specifications could result in reduced product performance, reduction of operable life, and/or reduction of overall reliability.

This product carries a **Moisture Sensitivity Level (MSL)** classification as shown below, and should be handled according to the requirements of the latest version of the joint industry standard **IPC/JEDEC J-STD-033**.

Device	Moisture Sensitivity Level (MSL) Classification
IX4351NE	MSL 1

3.2 ESD Sensitivity



This product is **ESD Sensitive**, and should be handled according to the industry standard **JESD-625**.

3.3 Soldering Profile

Provided in the table below is the **IPC/JEDEC J-STD-020** Classification Temperature (T_C) and the maximum dwell time the body temperature of these surface mount devices may be ($T_C - 5$)°C or greater. The Classification Temperature sets the Maximum Body Temperature allowed for these devices during reflow soldering processes.

Device	Classification Temperature (T_C)	Dwell Time (t_p)	Max Reflow Cycles
IX4351NE	260°C	30 seconds	3

3.4 Board Wash

IXYS Integrated Circuits recommends the use of no-clean flux formulations. Board washing to reduce or remove flux residue following the solder reflow process is acceptable provided proper precautions are taken to prevent damage to the device. These precautions include but are not limited to: using a low pressure wash and providing a follow up bake cycle sufficient to remove any moisture trapped within the device due to the washing process. Due to the variability of the wash parameters used to clean the board, determination of the bake temperature and duration necessary to remove the moisture trapped within the package is the responsibility of the user (assembler). Cleaning or drying methods that employ ultrasonic energy may damage the device and should not be used. Additionally, the device must not be exposed to halide flux or solvents.



3.5 Mechanical Dimensions

3.5.1 IX4351NE 16-Pin SOIC Package

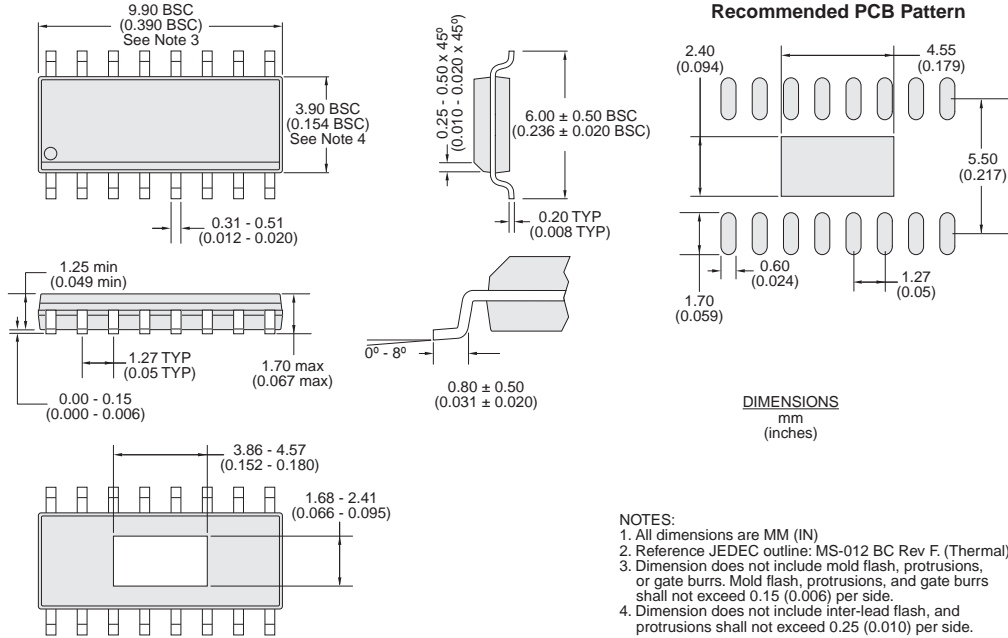

3.5.2 IX4351NETR Tape & Reel Packaging for 16-Pin SOIC Package

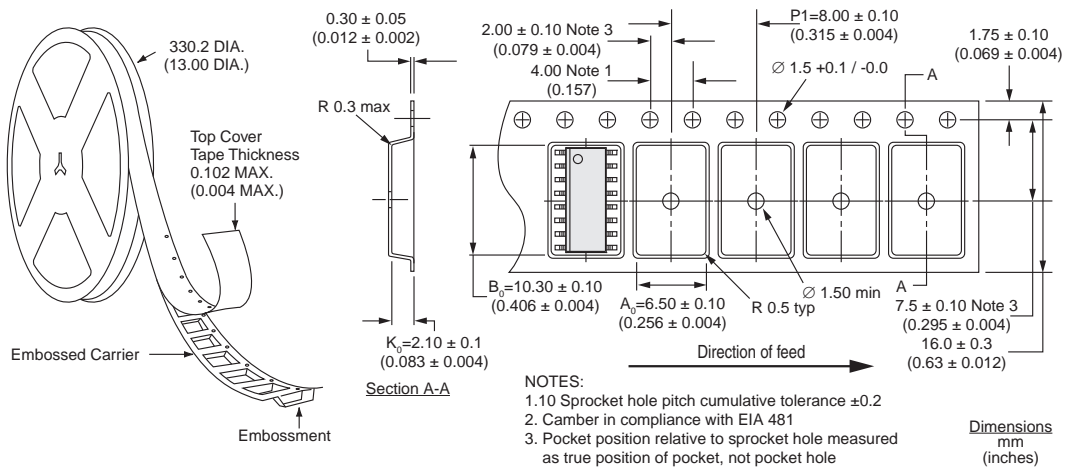

For additional information please visit our website at: www.ixysic.com

Disclaimer Notice - Littelfuse products are not designed for, and shall not be used for, any purpose (including, without limitation, automotive, military, aerospace, medical, life-saving, life-sustaining or nuclear facility applications. Components intended for surgical implant into the body, or any other application in which the failure or lack of desired operation of the product may result in personal injury, death, or property damage) other than those expressly set forth in applicable Littelfuse product documentation. Warranties granted by Littelfuse shall be deemed void for products used for any purpose not expressly set forth in applicable Littelfuse documentation. Littelfuse shall not be liable for any claims or damages arising out of products used in applications not expressly intended by Littelfuse as set forth in applicable Littelfuse documentation. The sale and use of Littelfuse products is subject to Littelfuse Terms and Conditions of Sale, unless otherwise agreed by Littelfuse. Information furnished is believed to be accurate and reliable. However, users should independently evaluate the suitability of and test each product selected for their own applications. Littelfuse products are not designed for, and may not be used in, all applications.

Read complete Disclaimer Notice at www.littelfuse.com/disclaimer-electronics.

Specification: DS-IX4351NE-R01
©Copyright 2019, Littelfuse, Inc.
All rights reserved. Printed in USA.
10/31/2019