

# 2PRO DEVICES

The 2Pro product is an integrated overcurrent/over-voltage protection device. The RoHS-compliant component incorporates PolySwitch PPTC (Polymeric Positive Temperature Coefficient) technology and MOV (Metal Oxide Varistor) technology in a single device to help reduce board space requirements and component count.

Damage to telephony communications equipment can be caused by various sources including lightning, electrostatic discharge (ESD), power contact and induction with AC lines. The 2Pro TM2P-10271 devices help provide current limiting during overcurrent events and voltage clamping during overvoltage events. After a fault condition is removed and power is cycled, 2Pro devices will reset so that the equipment remains operational.

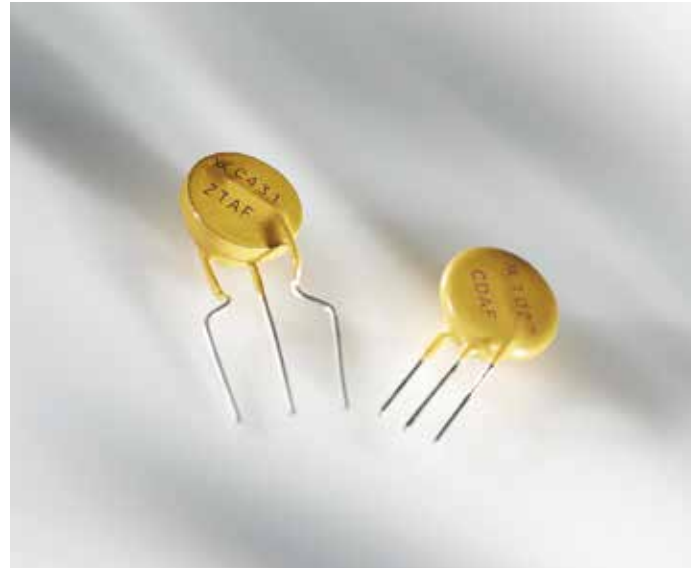

The 2Pro device helps address the need for resettable circuit protection devices for use in cost-sensitive PSTN (Public Switched Telephone Network) and VoIP (Voice over Internet Protocol) telephony equipment. The widespread use of VoIP gateways in homes and enterprise environments as the primary means of voice delivery requires the utmost safety and reliability in equipment. 2Pro circuit protection devices help manufacturers comply with global safety standards, including UL 60950, TIA-968-A, IEC 60950 and ITU-T K.20/K.21. The UL 497A listed protector also helps provide ESD protection.

## BENEFITS

- Single device helps reduce component count and footprint
- Helps reduce warranty returns
- Helps equipment comply with surge tests per: TIA-968-A, IEC 60950, ITU-T K.20/K.21
- Helps simplify UL 60950 testing
- Helps equipment comply with UL 60950

## FEATURES

- RoHS compliant
- Halogen free  
(refers to: Br≤900ppm, Cl≤900ppm, Br+Cl≤1500ppm)
- Single overcurrent, overvoltage and ESD protection device
- Resettable overcurrent protection
- UL 497A listed protector (#E258475)

## APPLICATIONS

- Cordless telephones
- VoIP gateways
- Fax machines
- Data modems
- Set-top boxes
- Security systems
- MDF modules
- Analog and ISDN linecards

Table 2P1 – Electrical Characteristics

| Overcurrent (terminals 1 – 2) – Performance ratings @ 20°C |                       |                       |                             |                  |                     |                               |      |       |
|--|-----------------------|-----------------------|-----------------------------|------------------|---------------------|-------------------------------|------|-------|
| Part Number  | I <sub>HOLD</sub> (A) | I <sub>TRIP</sub> (A) | Resistance <sup>†</sup> (Ω) |                  |                     | Time-to-Trip (s) <sup>†</sup> |      |       |
|  |                       |                       | R <sub>MIN</sub>            | R <sub>MAX</sub> | R <sub>1 MAX*</sub> | Typ                           | Max  |       |
| TM2P-10271   | 0.15                  | 0.30                  | 6.50                        | 14.00            | 16.00               | 0.90                          | 3.00 | (@1A) |
| LVM2P-015R10431  | 0.15                  | 0.30                  | 6.50                        | 14.00            | 16.00               | 0.90                          | 3.00 | (@1A) |
| LVM2P-035R14431  | 0.35                  | 0.75                  | 1.40                        | 2.20             | 2.80                | 0.50                          | 2.00 | (@3A) |
| LVM2P-075R14431  | 0.75                  | 1.50                  | 0.37                        | 0.80             | 1.00                | 0.90                          | 1.20 | (@7A) |

| Overvoltage (Terminals 2 – 3) |                          |           |                           |                      |                   |
|-------------------------------|--------------------------|-----------|---------------------------|----------------------|-------------------|
| Part Number                   | Varistor Voltage V @ 1mA |           | DC Resistance @ 100V (MΩ) | Maximum Clamping (V) | Rated Wattage (W) |
|                               | DC (V)                   | Tolerance |                           |                      |                   |
| TM2P-10271                    | 260                      | +14% -7%  | >10                       | 455 (@25A)           | 0.25              |
| LVM2P-015R10431               | 430                      | +10% -10% | >10                       | 710 (@ 25A)          | 0.25              |
| LVM2P-035R14431               | 430                      | +10% -10% | >10                       | 710 (@ 50A)          | 0.60              |
| LVM2P-075R14431               | 430                      | +10% -10% | >10                       | 710 (@ 50A)          | 1.00              |

\* Maximum device resistance at 20°C measured 1 hour post trip.  
 † Corresponds to operation below varistor voltages.

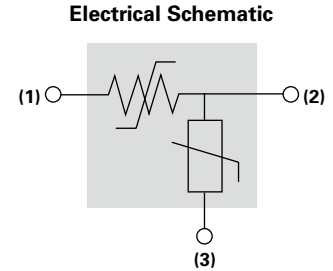

Table 2P2 – Dimensions in Millimeters and (Inches\*)

| Part Number            | A   |        | B   |        | C   |        | D      |        | E      | F   |        | Figure |
|------------------------|-----|--------|-----|--------|-----|--------|--------|--------|--------|-----|--------|--------|
|                        | Min | Max    | Min | Max    | Min | Max    | Min    | Max    | Nom    | Min | Max    |        |
| <b>TM2P-10271</b>      |     |        |     |        |     |        |        |        |        |     |        |        |
| mm                     | —   | 12.0   | —   | 15.0   | —   | 6.6    | 6.0    | —      | 2.5    | —   | 12.0   | 2P1    |
| in*                    | —   | (0.47) | —   | (0.59) | —   | (0.26) | (0.24) | —      | (0.10) | —   | (0.47) |        |
| <b>LVM2P-015R10431</b> |     |        |     |        |     |        |        |        |        |     |        |        |
| mm                     | —   | 12.0   | —   | 17.0   | —   | 7.4    | 8.5    | 11.5   | 5.1    | —   | —      | 2P2    |
| in*                    | —   | (0.47) | —   | (0.67) | —   | (0.29) | (0.34) | (0.45) | (0.20) | —   | —      |        |
| <b>LVM2P-035R14431</b> |     |        |     |        |     |        |        |        |        |     |        |        |
| mm                     | —   | 16.0   | —   | 21.0   | —   | 7.4    | 3.0    | 5.0    | 5.1    | —   | —      | 2P2    |
| in*                    | —   | (0.63) | —   | (0.83) | —   | (0.29) | (0.12) | (0.20) | (0.20) | —   | —      |        |
| <b>LVM2P-075R14431</b> |     |        |     |        |     |        |        |        |        |     |        |        |
| mm                     | —   | 16.0   | —   | 21.0   | —   | 7.4    | 3.0    | 5.0    | 2.5    | —   | —      | 2P3    |
| in*                    | —   | (0.63) | —   | (0.83) | —   | (0.29) | (0.12) | (0.20) | (0.10) | —   | —      |        |

\* The dimensions in inches are rounded approximations.

Figures 2P1-2P3 – Dimension Figures

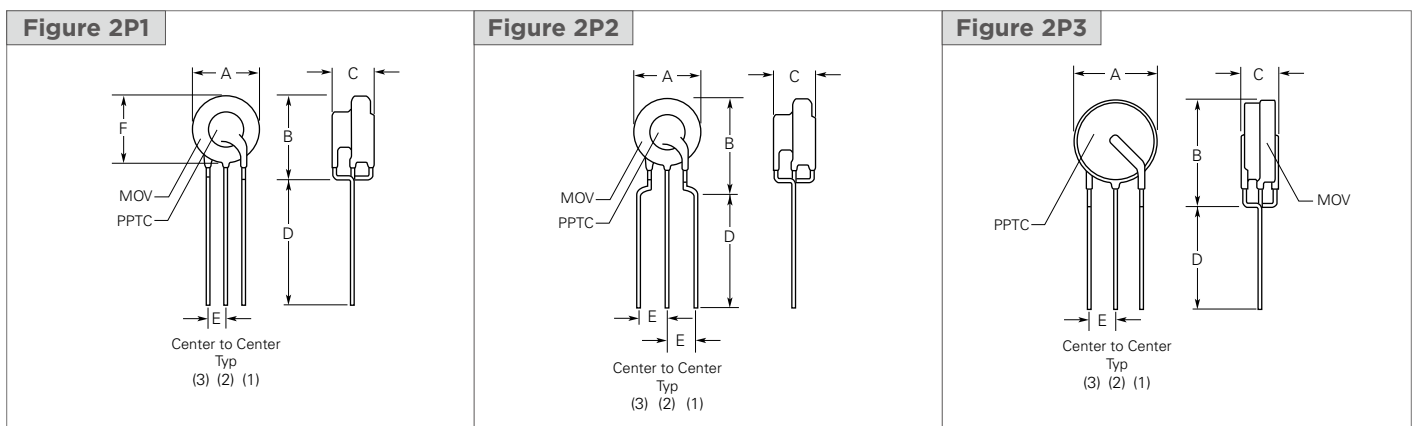

Figure 2P4 — Typical Time-to-Trip at 25°C

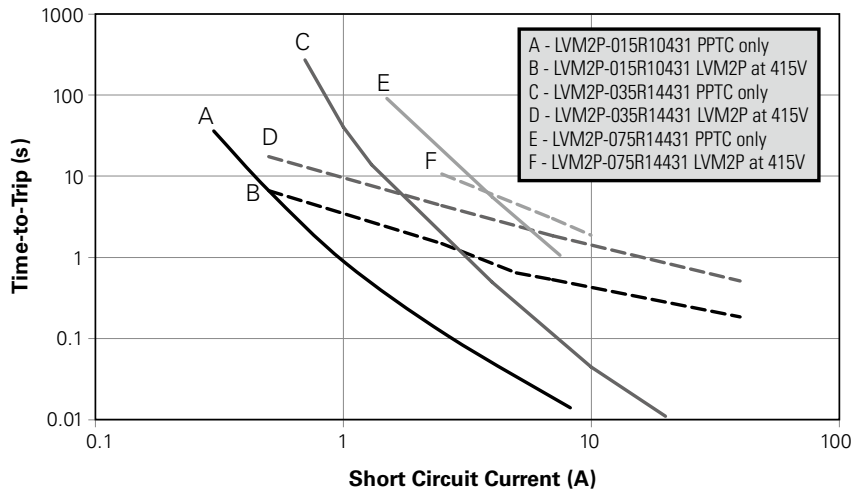

Table 2P3 — Physical Characteristics and Environmental Specifications

| Physical Characteristics     |  |
|------------------------------|--|
| Lead Material                | Tin-plated Copper, 0.33mm <sup>2</sup> (22AWG), 0.64mm (0.025in)                             |
| Flammability                 | IEC 695-2-2 Needle Flame Test for 20s  |
| Soldering Characteristics    | ANSI Approved IPC/EIA/JEDEC J-STD-002, Category 3  |
| Solder Heat Withstand        | per IEC-STD 68-2-20, Test Tb, Method1A, Condition B, can withstand 10 Seconds at 260°C ± 5°C |
| Environmental Specifications |  |
| Test                         | Conditions   |
| Passive Aging                | 60°C, 1000 Hours / 85°C, 1000 Hours  |
| Humidity Aging               | 85°C, 85% RH, 500 Hours  |
| Active Aging                 | 60°C, 90% RH, 60VDC Bias, 1000 Hours   |
| Thermal Shock                | 125°C, -55°C (10 Times)  |
| Solvent Resistance           | MIL-STD-202, Method 215K   |

**Note:** Storage conditions: 40°C max, 70% RH max, devices should remain in original sealed bag prior to use. Devices may not meet specified values if these storage conditions are exceeded.

Table 2P4 – Packaging and Marking Information

| Part Number     | Bag Quantity | Tape and Reel Quantity | Standard Package | Part Marking   | Agency Recognition   |
|-----------------|--------------|------------------------|------------------|----------------|--|
| TM2P-10271      | 250          | —                      | 3,000            | 1027 & Batch # | UL 497A/File No. E258475                                     |
| TM2P-10271-2    | —            | 1,000                  | 5,000            | 1027 & Batch # | UL 497A/File No. E258475                                     |
| LVM2P-015R10431 | 250          | —                      | 3,000            | C431 & Batch # | MOV UL 1449/File No. E332226<br>PPTC UL 1434/File No. E74889 |
| LVM2P-035R14431 | 250          | —                      | 3,000            | A431 & Batch # |  |
| LVM2P-075R14431 | 250          | —                      | 3,000            | B431 & Batch # |  |

Table 2P5 – Ordering Information

|             |       |             |
|-------------|-------|-------------|
| Bulk        | 250   | pieces/bag  |
|             | 3,000 | pieces/box  |
| Tape & Reel | 1,000 | pieces/reel |
|             | 5,000 | pieces/box  |

## Wave Soldering and Rework Recommendations

### Recommended Wave Soldering for Radial-leaded Devices

- Soldering temperature profile  
(Temperature characteristic at component terminal with dual wave soldering)

### Rework

- If a device is removed from the board, it should be discarded and replaced with a new device

Figure 2P5

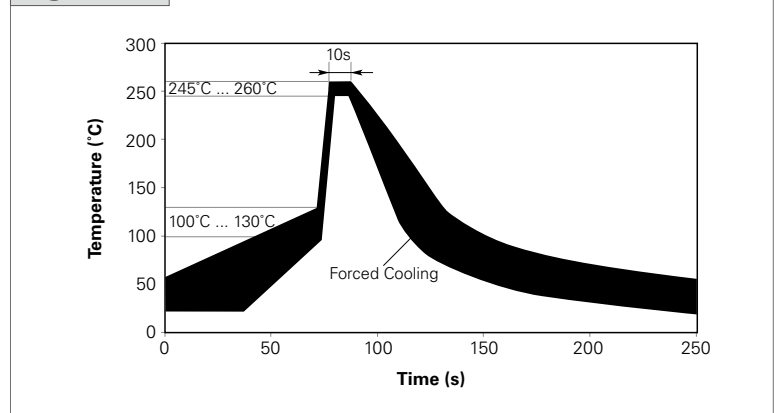

Table 2P6 — Tape and Reel Specifications in Millimeters (mm)

2Pro devices are available in tape and reel packaging per EIA 468-B standard. See Figures 2P6 and 2P7 for details.

| Description                           | EIA Mark                        | IEC Mark                        | Dimension (mm) | Tolerance   |
|---------------------------------------|---------------------------------|---------------------------------|----------------|-------------|
| Carrier Tape Width                    | W                               | W                               | 18             | -0.5/ +1.0  |
| Hold Down Tape Width                  | W <sub>4</sub>                  | W <sub>0</sub>                  | 5              | Min         |
| Top Distance Between Tape Edges       | W <sub>6</sub>                  | W <sub>2</sub>                  | 3              | Max         |
| Sprocket Hole Position                | W <sub>5</sub>                  | W <sub>1</sub>                  | 9              | -0.5/ +0.75 |
| Sprocket Hole Diameter                | D <sub>0</sub>                  | D <sub>0</sub>                  | 4              | ±0.2        |
| Abcissa to Plane (Kinked Lead)*       | H <sub>0</sub>                  | H <sub>0</sub>                  | 16             | -0.5/0.6    |
| Abcissa to Top                        | H <sub>1</sub>                  | H <sub>1</sub>                  | 32.2           | Max         |
| Overall Width with Lead Protrusion    | —                               | C <sub>1</sub>                  | 43.2           | Max         |
| Overall Width Without Lead Protrusion | —                               | C <sub>2</sub>                  | 42.5           | Max         |
| Lead Protrusion                       | L <sub>1</sub>                  | I <sub>1</sub>                  | 1.0            | Max         |
| Protrusion of Cut-out                 | L                               | L                               | 11             | Max         |
| Protrusion Beyond Hold Down Tape      | I <sub>2</sub>                  | I <sub>2</sub>                  | Not Specified  | —           |
| Sprocket Hole Pitch                   | P <sub>0</sub>                  | P <sub>0</sub>                  | 12.7           | ±0.3        |
| Pitch Tolerance                       | —                               | —                               | 20 Consecutive | ±1          |
| Tape Thickness                        | t                               | t                               | 0.9            | Max         |
| Tape Thickness with Splice*           | t <sub>1</sub>                  | —                               | 2.0            | Max         |
| Splice Sprocket Hole Alignment        | —                               | —                               | 0              | ±0.3        |
| Body Lateral Deviation                | Δh                              | Δh                              | 0              | ±0.1        |
| Body Tape Plane Deviation             | Δp                              | Δp                              | 0              | ±1.3        |
| Ordinate to Component Center Lead     | P <sub>2</sub>                  | P <sub>2</sub>                  | 6.35           | ±0.7        |
| Lead Spacing*                         | F <sub>1</sub> , F <sub>2</sub> | F <sub>1</sub> , F <sub>2</sub> | 2.54           | -0.1/+0.4   |
| Reel Width                            | w <sub>2</sub>                  | w                               | 56             | Max         |
| Reel Diameter                         | a                               | d                               | 370            | Max         |
| Space Between Flanges                 | w <sub>1</sub>                  | —                               | 51.2           | Max         |
| Arbor Hole Diameter                   | c                               | f                               | 26             | ±12.0       |
| Core Diameter                         | n                               | h                               | 80             | Max         |
| Box                                   | —                               | —                               | 56/372/372     | Max         |
| Consecutive Missing Pieces*           | —                               | —                               | 3 Max          | —           |
| Empty Places Per Reel*                | —                               | —                               | Not Specified  | —           |

Note: \*Differs from EIA specification.

Figure 2P6 — EIA Referenced Taped Component Dimensions

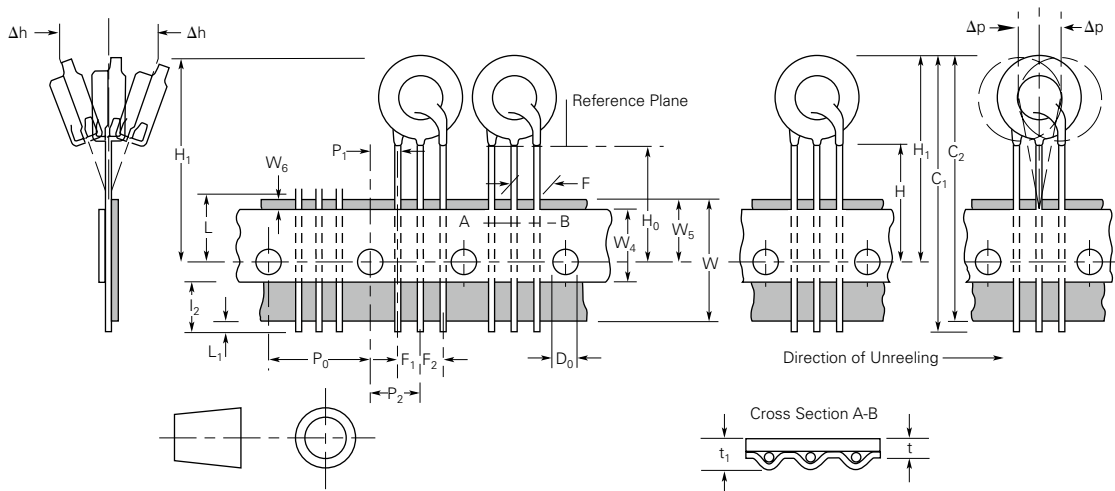
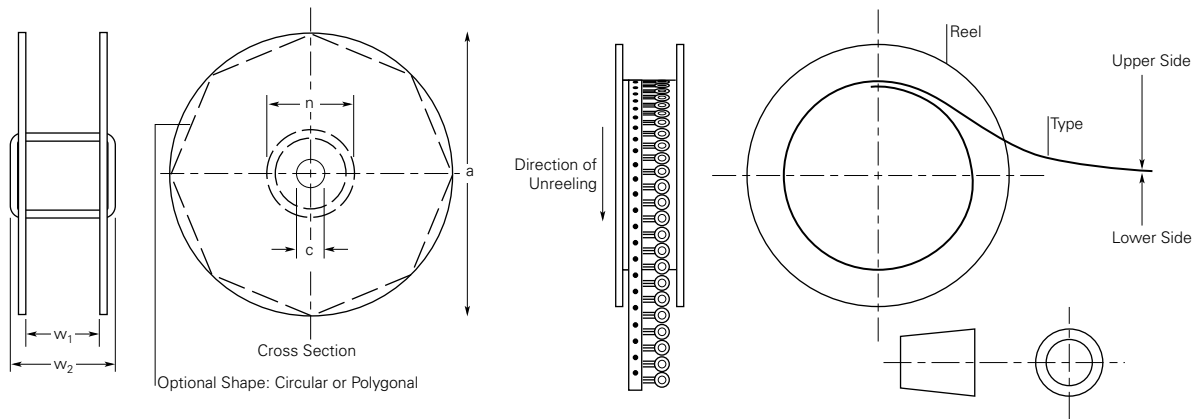
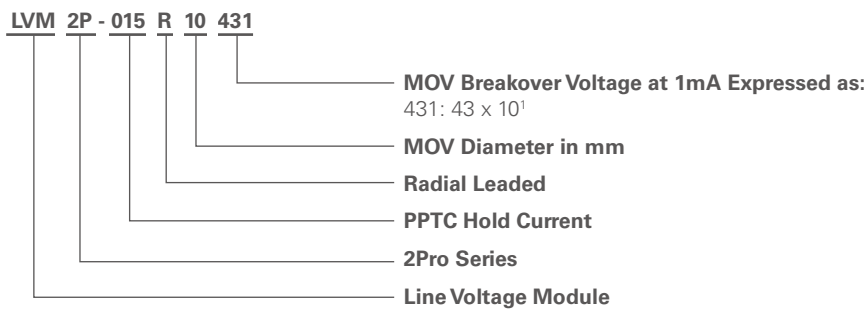
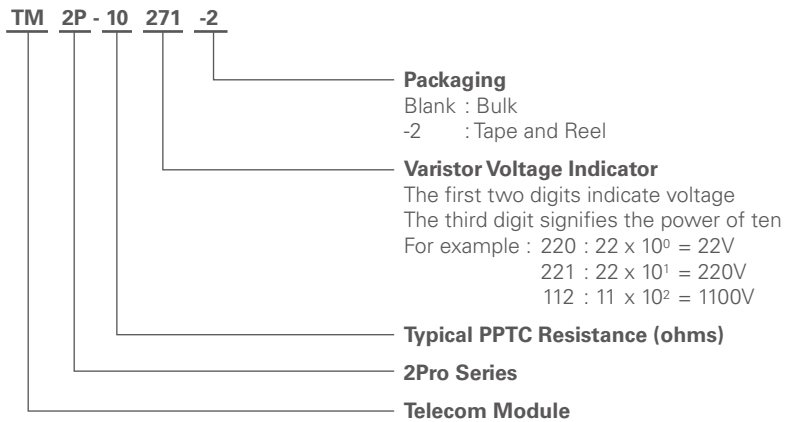

Figure 2P7 – EIA Referenced Reel Dimensions



## Part Numbering System

**Notice:**

Information furnished is believed to be accurate and reliable. However, users should independently evaluate the suitability and test each product selected for their own applications. Tyco Electronics Corporation and its affiliates in the TE Connectivity Ltd. group of companies ("TE") reserves the right to change or update, without notice, any information contained in this publication; to change, without notice, the design, construction, processing, or specification of any product; and to discontinue or limit production or distribution of any product. This publication supersedes and replaces all information previously supplied. Without express written consent by an officer of TE, TE does not authorize the use of any of its products as components in nuclear facility applications, aerospace, or in critical life support devices or systems. TE expressly disclaims all implied warranties regarding the information contained herein, including, but not limited to, any implied warranties of merchantability or fitness for a particular purpose. TE's only obligations are those in the TE Standard Terms and Conditions of Sale and in no case will TE be liable for any incidental, indirect, or consequential damages arising from the sale, resale, use, or misuse of its products.