

Typical Unit

Output Voltage (V)	Output Current (A)	Input Voltage Range (V)
12	21	16-160
24	10.5	16-160
54	4.5	16-160

Optimized for embedded applications on railway rolling stock environments, the IRH-W80 DC-DC Converter range offers 250W single output from a 10:1 ratio input voltage range in an industry standard half brick solution.

FEATURES

- Efficiency up to 91% @ 72Vin, 12Vout
- Ultra wide input range: 16V-160V
- Output voltages of: 12V, 24V or 54V
- Vout external trim adjustment
- Output power 250W
- Half-brick Package Dimension, Inches (mm): 2.488 x 2.390 x 0.55 (63.2 x 60.7 x 14)
- OVP, OCP, OTP.
- Positive or Negative Remote ON/OFF
- Operating Baseplate Temp. -40°C to +100°C
- 4242VDC input to output reinforced isolation
- Hold up time (10-30mS)
- UVLO Set up (resistor programmable)
- Conformally Coated PCB
- Encapsulated for harsh environment
- Meets requirements for EN50155

SAFETY FEATURES

- 4242Vdc input to output isolation
- Reinforced isolation
- UL 60950-1, 2nd Edition
- IEC/EN60950-1, 2nd Edition
- RoHS compliant

PRODUCT OVERVIEW

The IRH-W80 series of isolated regulated converter modules, deliver an impressive 250W single output from an ultra wide input voltage range of 16V – 160V DC, complying with the input battery voltage transient ranges of EN50155 (2017). The industry standard half brick package offers high efficiency levels up to 91%. The fully isolated (4242Vdc) DC-DC module accepts a wide input voltage range of 16V – 160VDC, while maintaining a fully regulated single output. The output voltage

features Overvoltage, Overcurrent, short circuit, and Overtemperature protection. Other features include – adjustable Undervoltage lockout protection, adjustable Current limit threshold, Positive or Negative Logic enable and a Hold Up Pin to allow connection of an external capacitor.

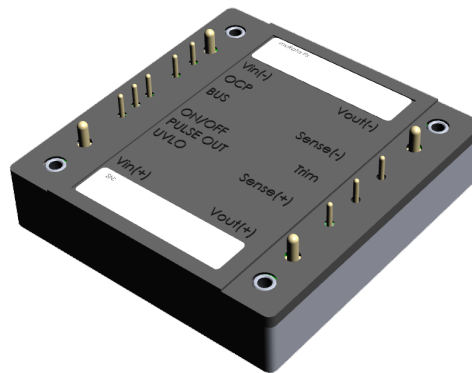

Encapsulated Half-Brick



PERFORMANCE SPECIFICATIONS SUMMARY AND ORDERING GUIDE [1] [2]

Root Model [1]	Output						Input				Efficiency	Package	
	V _{out} (V)	I _{out} (A, max.)	Power (W)	Ripple & Noise (mV pk-pk)		Regulation [3] (max.)		V _{in} Nom. (V)	V _{in} Range (V)	I _{in} , no load (mA)			I _{in} , full load (A)
				Typ.	Max.	Line	Load				Typ.	Case (mm)	
IRH-12/21-W80	12	21	250	150	300	±0.2%	±0.2%	72	16-160	60	20	91%	63.2 x 60.7 x 14
IRH-24/10.5-W80 [4]	24	10.5	250	300	300	±0.25%	±0.25%	72	16-160	60	20	90%	63.2 x 60.7 x 14
IRH-54/4.5-W80 [4]	54	4.5	250	TBD	TBD	TBD	TBD	72	16-160	TBD	TBD	TBD	63.2 x 60.7 x 14

Under Development
Under Development

Notes:

- [1] Please refer to the Part Number Structure when ordering.
- [2] All specifications are at nominal line voltage and full load, +25°C unless otherwise noted. See detailed specifications. Output capacitors are 1 µF ceramic multilayer in parallel with 10 µF I/O caps are necessary for our test equipment and may not be needed for your application.
- [3] Regulation specifications describe output voltage deviations from a nominal/midpoint value to either extreme (50% load step).
- [4] The 24Vout and 54Vout models are currently in development.

PART NUMBER STRUCTURE

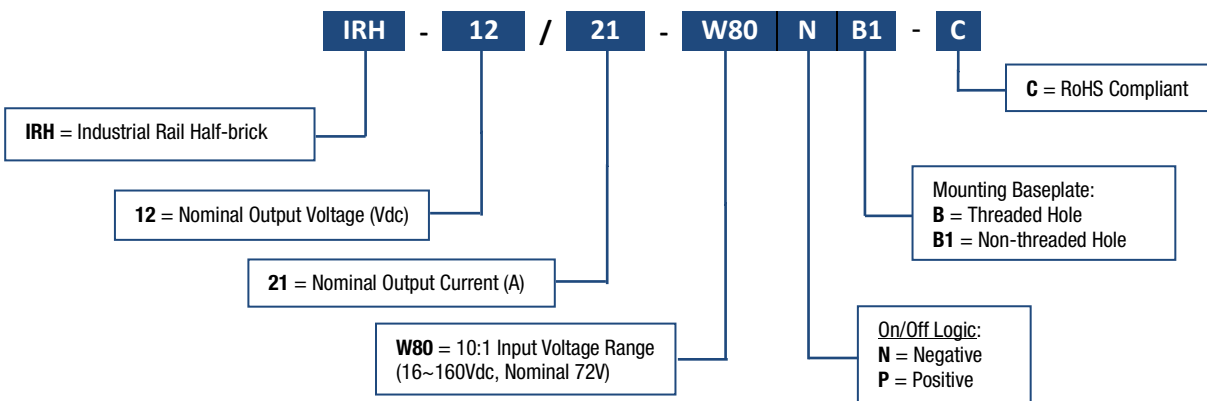

NOTE: Some model number combinations may not be available. Please contact Murata Power Solutions.

IRH-12/21-W80, FUNCTIONAL SPECIFICATIONS

ABSOLUTE MAXIMUM RATINGS		CONDITONS	MIN.	TYP.	MAX.	UNITS
Input Voltage						
Non-Operating	Continuous				175	Vdc
Operating	Continuous				160	Vdc
Transient Operating	100mS				170	Vdc
Operating Ambient Temperature		-40			85	°C
Operating Case Temperature		-40			100	°C
Storage Temperature		-45			125	°C
Input/Output Isolation Voltage					4242	Vdc
Voltage at ON/OFF input pin		3			5	Vdc
Absolute maximums are stress ratings. Exposure of devices to greater than any of these conditions may adversely affect long-term reliability. Proper operation under conditions other than those listed in the Performance/Functional Specifications Table is not implied or recommended.						
INPUT CHARACTERISTICS						
Operating Input Voltage Range			16	72	160	Vdc
Input Under-Voltage Lockout						
Turn-On Voltage Threshold			13	14	15	Vdc
Turn-Off Voltage Threshold			10	11	12	Vdc
Lockout Voltage Hysteresis				3		Vdc
Maximum Input Current	100% Load, 16Vin				20	A
No-Load Input Current	Vin=72V, Io=0A			60		mA
Disabled Input Current (Option N)					20	mA
Disabled Input Current (Option P)					20	mA
Input Reflected Ripple Current	Measured at the input of module with a simulated source impedance of 12μH, 220μF, 200V, across source, 220μF, 200V external capacitors across input pins				600	mAp-p
Input Reflected Ripple Current	No filtering				800	mAp-p
Recommended Input Capacitance	An electrolytic cap (low ESR preferred)			100		μF
Recommended External BUS Capacitance	An electrolytic cap (low ESR preferred)			240		μF
Inrush Current (I _{in})				20	30	A ² S
OUTPUT CHARACTERISTICS						
Output Voltage Set Point	Vin=72V, Io=0A, Ta=25°C		11.88	12.00	12.12	Vdc
Output Voltage Regulation						
Over Load	I _{out} = I _{out} min to I _{out} max			±0.05	±0.20	%
Over Line	I _{out} =Full load, Vin = 16 to 160V,			±0.01	±0.20	%
Over Temperature	Vin=72V, Tc = Min to Max case temperature			±0.004	±0.01	%/°C
Total Output Voltage Range	Over sample, line, load, temperature&life		11.64		12.36	Vdc
Output Voltage Ripple and Noise						
Peak-to-Peak				150	300	mVp-p
RMS				30	60	mVrms
Operating Output Current Range			0		21	A
Output DC Current-Limit Inception	Output Voltage 10% Low		23	26	30	A
Output Capacitance	Nominal Vout at full load(resistive load)		0		2200	μF
DYNAMIC CHARACTERISTICS						
Output Voltage During Load Current Transient						
Step Change in Output Current (0.1A/uS)	50% I _{out} Max to 75%			280	450	mV
Step Change in Output Current (0.1A/uS)	75% I _{out} max to 50%			280	450	mV
Settle Time	To within 1% Vout nom				150	uS
Turn-On Transient						
Start-up Time, From ON/OFF Control	See Figures @ Vin=72V			95	460	mS
Start-up Time, From Input	See Figures @ Vin=72V			160	460	mS
Rise Time	Time from 10% to 90% of nominal output voltage				100	mS
Output Voltage Overshoot					2	%
GENERAL and SAFETY		CONDITIONS	MIN.	TYP.	MAX.	UNITS
Efficiency						
100% Load	Vin=72V, Details see Figures			91		%
50% Load	Vin=72V, Details see Figures			92		%
Isolation						
Isolation Voltage	Input to Output (Reinforced insulation)				4242	Vdc
	Input to Baseplate				2250	Vdc
	Output to Baseplate				2250	Vdc

IRH-12/21-W80, FUNCTIONAL SPECIFICATIONS

Isolation Resistance	Input/Output		20		MΩ
Isolation Capacitance	Input/Output		500		pF
Safety	Certified to UL-60950-1, IEC/EN60950-1, 2nd edition		Yes		
Calculated MTBF	Per Belcore Telcordia SR332, Issue 2, Method 1, Class 1		1.48		MHrs
TEMPERATURE LIMITS FOR POWER DERATING CURVES					
Semiconductor Junction Temperature				125	°C
Board Temperature	UL rated max operating temp 130°C			125	°C
Transformer/Inductor Temperature				125	°C
FEATURE CHARACTERISTICS					
Switching Frequency		216	240	264	kHz
ON/OFF Control (Option P)					
Off-State Voltage		0		0.4	V
On-State Voltage		3		5	V
ON/OFF Control (Option N)					
Off-State Voltage		3		5	V
On-State Voltage		0		0.4	V
ON/OFF Control Current (Either Option)					
Current thru ON/OFF pin	Von/off=0V			1	mA
Current thru ON/OFF pin	Von/off=5V			2	mA
Output Voltage Trim Range	Pout<=Max rated power	-20		10	%
Trim Up Equations	Please see TRIM functions technical notes				
Trim Down Equations	Please see TRIM functions technical notes				
Output Over-Voltage Protection	Hiccup mode; over full temp range; % of nominal Vout	110	120	130	%
Over-Temperature Shutdown			125		°C
THERMAL IMPEDANCE					
Vin=16V	Full load, component to baseplate		0.93		K/W
Vin=16.8V	Full load, component to baseplate		0.88		K/W
Vin=24V	Full load, component to baseplate		0.71		K/W
Vin=28V	Full load, component to baseplate		0.73		K/W
Vin=36V	Full load, component to baseplate		0.77		K/W
Vin=48V	Full load, component to baseplate		0.84		K/W
Vin=72V	Full load, component to baseplate		0.90		K/W
Vin=96V	Full load, component to baseplate		1.01		K/W
Vin=110V	Full load, component to baseplate		1.02		K/W
Vin=137.5V	Full load, component to baseplate		1.06		K/W
Vin=160V	Full load, component to baseplate		1.09		K/W
MECHANICAL					
Outline Dimensions	Standard Baseplate		2.488 x 2.390 x 0.550		Inches
(Please refer to outline drawing)	L x W x H		63.20 x 60.70 x 14.00		mm
Weight			5		Ounces
			145		Grams
Through Hole Pin Diameter			0.040 & 0.080		Inches
			1.016 & 2.032		mm
Through Hole Pin Material			Copper alloy		
EMI/RFI Shielding			N/A		

TYPICAL PERFORMANCE DATA: IRH-12/21-W80

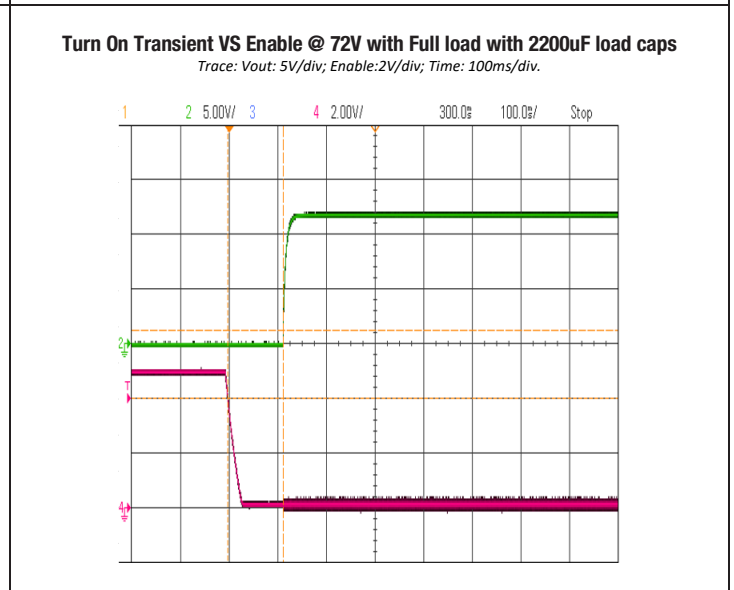
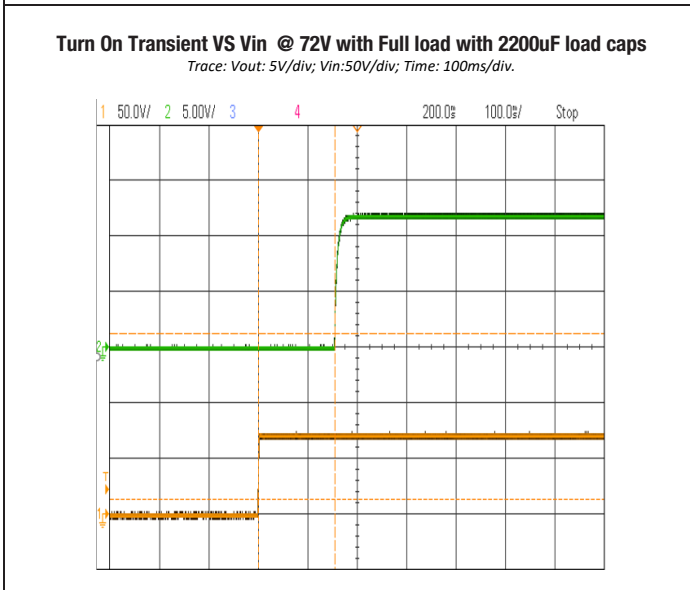
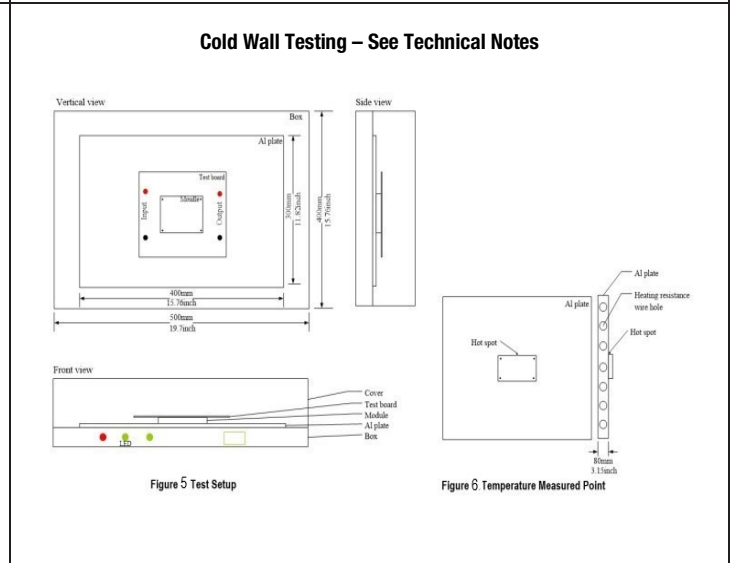
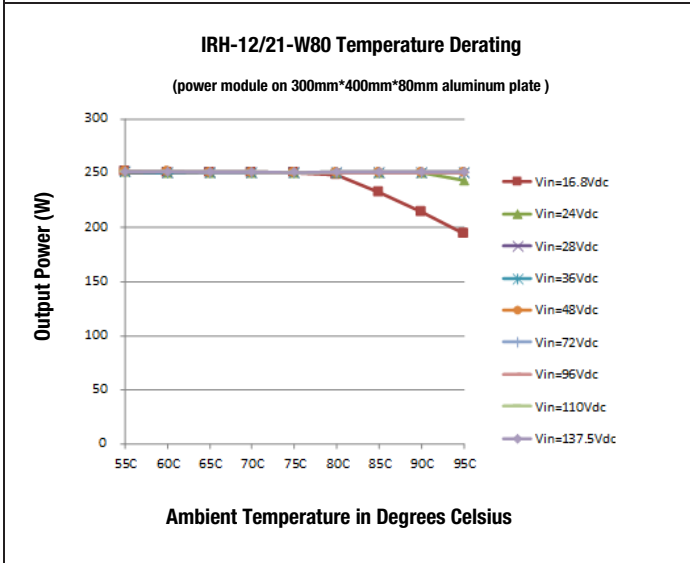
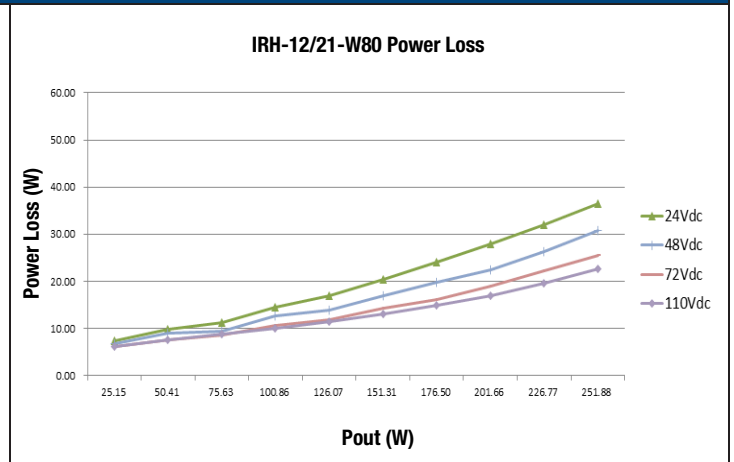
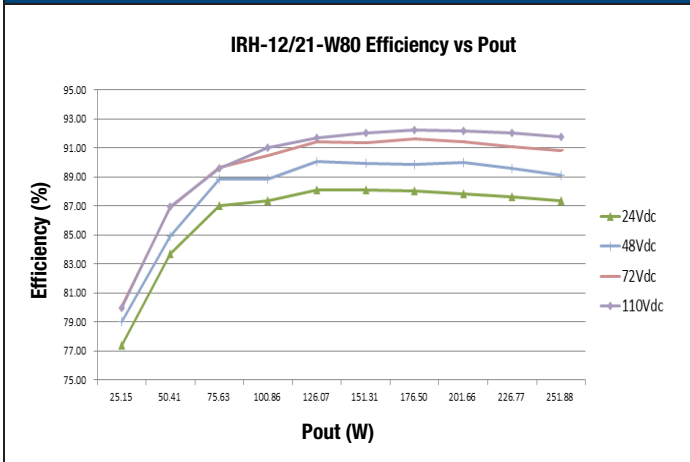

TYPICAL PERFORMANCE DATA: IRH-12/21-W80

Output voltage response to step-change in load current
Vin=72V (50%-75%-50% of full load; di/dt = 0.1A/μs).
 Trace: Vout: 100mV/div; Iout: 5A/div; Time: 200us/div



Output Ripple@20MHz BW,
Vin = 72Vdc, Full Load with 2200uF output capacitance
 Trace: Vout: 20mV/div; Time: 20us/div

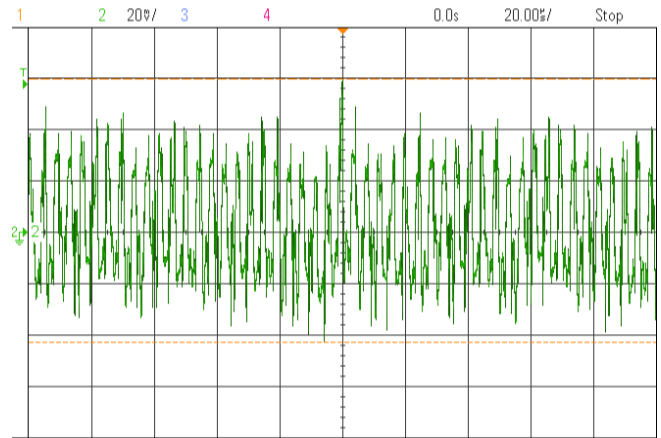

IRH-24/10.5-W80, FUNCTIONAL SPECIFICATIONS

ABSOLUTE MAXIMUM RATINGS	CONDITONS	MIN.	TYP.	MAX.	UNITS
Input Voltage					
Non-Operating	Continuous			175	Vdc
Operating	Continuous			160	Vdc
Transient Operating	100mS			170	Vdc
Operating Ambient Temperature		-40		85	°C
Operating Case Temperature		-40		100	°C
Storage Temperature		-45		125	°C
Input/Output Isolation Voltage				4242	Vdc
Voltage at ON/OFF input pin		3		5	Vdc
Absolute maximums are stress ratings. Exposure of devices to greater than any of these conditions may adversely affect long-term reliability. Proper operation under conditions other than those listed in the Performance/Functional Specifications Table is not implied or recommended.					
INPUT CHARACTERISTICS					
Operating Input Voltage Range		16	72	160	Vdc
Input Under-Voltage Lockout					
Turn-On Voltage Threshold		13	14	15	Vdc
Turn-Off Voltage Threshold		10	11	12	Vdc
Lockout Voltage Hysteresis			3		Vdc
Maximum Input Current	100% Load, 16Vin			20	A
No-Load Input Current	Vin=72V, Io=0A		60	90	mA
Disabled Input Current (Option N)				20	mA
Disabled Input Current (Option P)				20	mA
Input Reflected Ripple Current	Measured at the input of module with a simulated source impedance of 12μH, 220μF, 200V, across source, 220μF, 200V external capacitors across input pins			TBD	mAp-p
Input Reflected Ripple Current	No filtering			TBD	mAp-p
Recommended Input Capacitance	An electrolytic cap (low ESR preferred)		100		μF
Recommended External BUS Capacitance	An electrolytic cap (low ESR preferred)		240		μF
Inrush Current (I ² t)			20	30	A ² S
OUTPUT CHARACTERISTICS					
Output Voltage Set Point	Vin=72V, Io=0A, Ta=25°C	23.76	24.00	24.24	Vdc
Output Voltage Regulation					
Over Load	Iout = Iout min to Iout max			±0.25	%
Over Line	Iout=Full load, Vin = 16 to 160V,			±0.25	%
Over Temperature	Vin=72V, Tc = Min to Max case temperature		±0.02	±0.02	%/°C
Total Output Voltage Range	Over sample, line, load, temperature & life	23.28		24.72	Vdc
Output Voltage Ripple and Noise					
Peak-to-Peak	20MHz bandwidth		300	300	mVp-p
RMS			30	60	mVrms
Operating Output Current Range		0		10.5	A
Output DC Current-Limit Inception	Output Voltage 10% Low	12	14	17	A
Output Capacitance	Nominal Vout at full load(resistive load)	0		2200	μF
DYNAMIC CHARACTERISTICS					
Output Voltage During Load Current Transient					
Step Change in Output Current (0.1A/uS)	50% Iout Max to 75%		150	450	mV
Step Change in Output Current (0.1A/uS)	75% Iout max to 50%		150	450	mV
Settle Time	To within 1% Vout nom			150	uS
Turn-On Transient					
Start-up Time, From ON/OFF Control	See Figures @ Vin=72V		95	460	mS
Start-up Time, From Input	See Figures @ Vin=72V		160	460	mS
Rise Time	Time from 10% to 90% of nominal output voltage			100	mS
Output Voltage Overshoot				2	%
GENERAL and SAFETY					
Efficiency					
100% Load	Vin=72V, Details see Figures		90		%
50% Load	Vin=72V, Details see Figures		90		%
Isolation					
Isolation Voltage	Input to Output (Reinforced insulation)			4242	Vdc
	Input to Baseplate			2250	Vdc
	Output to Baseplate			2250	Vdc

IRH-24/10.5-W80, FUNCTIONAL SPECIFICATIONS

Isolation Resistance	Input/Output		20		MΩ
Isolation Capacitance	Input/Output		500		pF
Safety	Certified to UL-60950-1, IEC/EN60950-1, 2nd edition		Yes		
Calculated MTBF	Per Belcore Telcordia SR332, Issue 2, Method 1, Class 1		TBD		MHrs
TEMPERATURE LIMITS FOR POWER DERATING CURVES					
Semiconductor Junction Temperature				125	°C
Board Temperature	UL rated max operating temp 130°C			125	°C
Transformer/Inductor Temperature				125	°C
FEATURE CHARACTERISTICS					
Switching Frequency		216	240	264	kHz
ON/OFF Control (Option P)					
Off-State Voltage		0		0.4	V
On-State Voltage		3		5	V
ON/OFF Control (Option N)					
Off-State Voltage		3		5	V
On-State Voltage		0		0.4	V
ON/OFF Control Current (Either Option)					
Current thru ON/OFF pin	Von/off=0V			1	mA
Current thru ON/OFF pin	Von/off=5V			2	mA
Output Voltage Trim Range	Pout<=Max rated power	-20		10	%
Trim Up Equations	Please see TRIM functions technical notes				
Trim Down Equations	Please see TRIM functions technical notes				
Output Over-Voltage Protection	Hiccup mode; over full temp range; % of nominal Vout	110	120	130	%
Over-Temperature Shutdown			125		°C
THERMAL IMPEDANCE					
Vin=16V	Full load, component to baseplate		TBD		K/W
Vin=16.8V	Full load, component to baseplate		TBD		K/W
Vin=24V	Full load, component to baseplate		TBD		K/W
Vin=28V	Full load, component to baseplate		TBD		K/W
Vin=36V	Full load, component to baseplate		TBD		K/W
Vin=48V	Full load, component to baseplate		TBD		K/W
Vin=72V	Full load, component to baseplate		TBD		K/W
Vin=96V	Full load, component to baseplate		TBD		K/W
Vin=110V	Full load, component to baseplate		TBD		K/W
Vin=137.5V	Full load, component to baseplate		TBD		K/W
Vin=160V	Full load, component to baseplate		TBD		K/W
MECHANICAL					
Outline Dimensions	Standard Baseplate		2.488 x 2.390 x 0.550		Inches
(Please refer to outline drawing)	L x W x H		63.20 x 60.70 x 14.00		mm
Weight	With Baseplate		5		Ounces
			145		Grams
Through Hole Pin Diameter			0.040 & 0.080		Inches
			1.016 & 2.032		mm
Through Hole Pin Material			Copper alloy		
EMI/RFI Shielding			N/A		

MECHANICAL SPECIFICATIONS

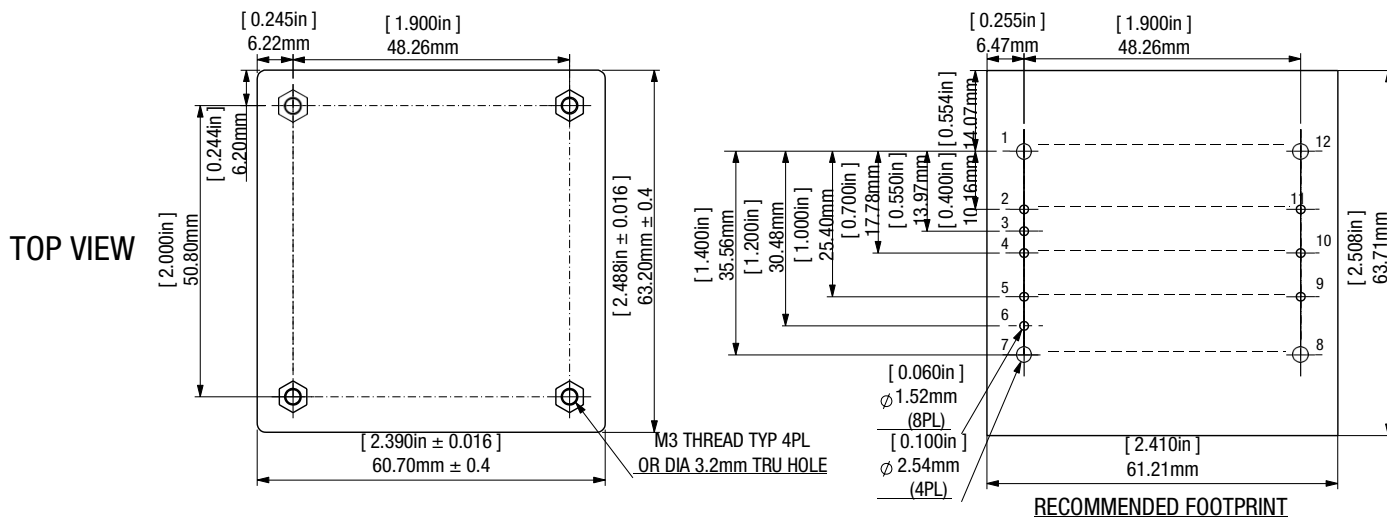

SIDE VIEW

BOTTOM VIEW

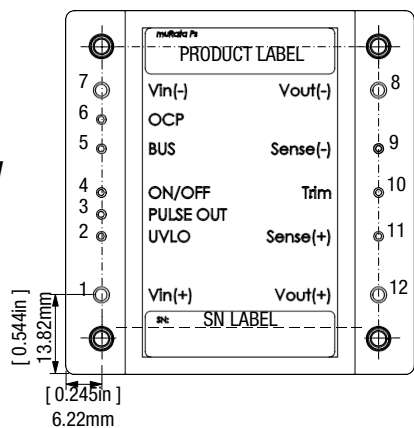

INPUT/OUTPUT CONNECTIONS		
Pin	Designation	Function
1	Vin (+)	Positive Input
2	UVLO	Under Voltage Lockout
3	PULSE OUT	PULSE OUT
4	ON/OFF	ENABLE
5	BUS	BUS Voltage
6	OCP	Over Current Protection
7	Vin (-)	Negative Input
8	Vout (-)	Negative Output
9	Sense (-)	Sense (-)
10	Trim	Trim
11	Sense (+)	Sense (+)
12	Vout (+)	Positive Output

Dimensions are in inches (mm) shown for ref. only.

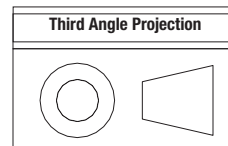

Tolerances (unless otherwise specified):
 .XX ± 0.02 (0.5)
 .XXX ± 0.010 (0.25)
 Angles ± 1°

NOTES:

- UNLESS OTHERWISE SPECIFIED:
- ALL DIMENSION ARE IN INCHES [MILIMETER].
 - ALL TOLERANCES:
 ×.××in, ±0.02in (×.×mm, ±0.5mm).
 ×.×××in, ±0.01in (×.××mm, ±0.25mm).
 - APPLIED TORQUE PER SCREW SHOULD NOT EXCEED 5.3in-lb (0.6Nm).
 - PIN 2-6, 9-11: DIA 0.040in PINS: COPPER ALLOY.
 PIN 1, 7, 8, 12: DIA 0.080in PINS: COPPER ALLOY.
 FINISH: GOLD (5u" MIN) OVER NICKEL (100u" MIN).

MOUNTING BASEPLATE WITH STANDARD M3 THREADED RIVET

NOTE: The mounting screws and heat sink are for reference only. They are not included with the IRH.

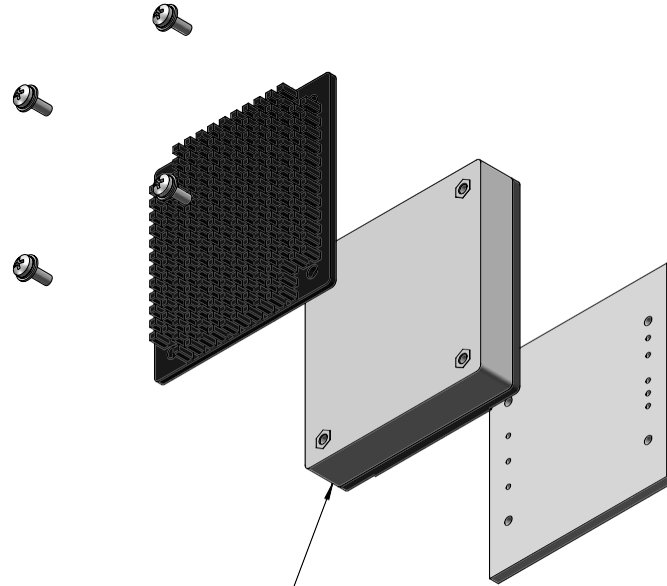

WITH THREADED HOLE

MOUNTING BASEPLATE WITH UNTHREADED INSERT

NOTE: The mounting screws and heat sink are for reference only. They are not included with the IRH.

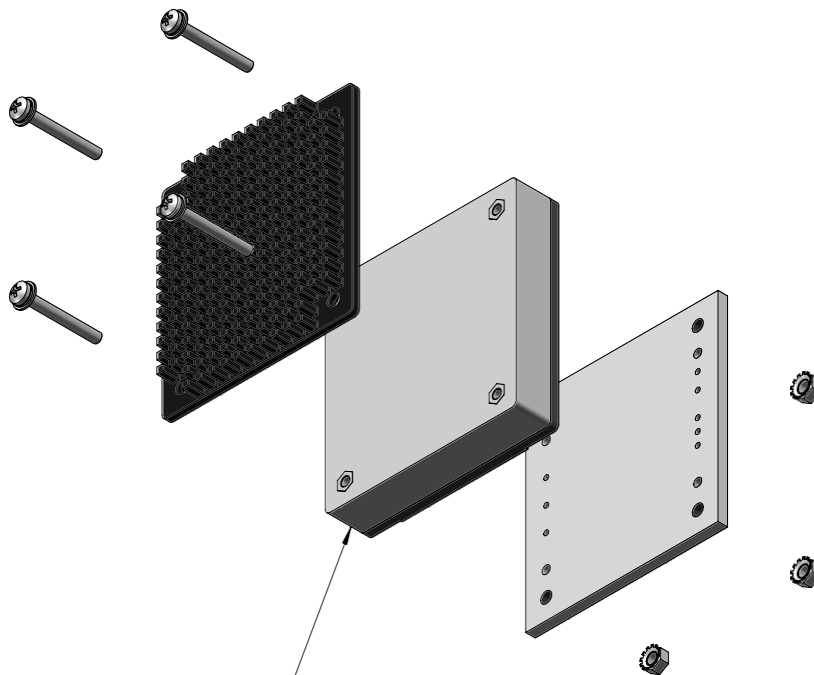

WITH UNTHREADED HOLE

TECHNICAL NOTES

On/Off Control

The input-side, remote On/Off Control function (pin 4) can be ordered to operate with either logic type:

Negative (“N” suffix): Negative-logic devices are off when pin 4 is left open (or pulled high, applying +3V to +5V), and on when pin 4 is pulled low (0 to 0.4V) with respect to –Input as shown in Figure 1.

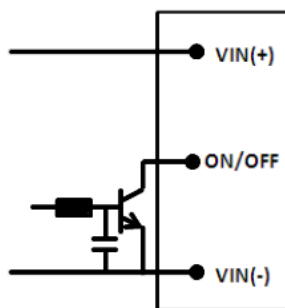

Figure 1. Driving the Negative Logic On/Off Control Pin

Remote On/Off can be controlled by an external switch between the On/Off terminal and the Vin(-) terminal. The switch can be an open collector or open drain. For negative logic if the remote on/off feature is not used, please short the On/Off pin to Vin(-). For positive logic if the remote On/Off feature is not used, please leave the On/Off pin floating. NOTE: Applying an external voltage to pin 4 when no input power is applied to the converter can cause permanent damage to the converter.

Input Fusing

Certain applications and/or safety agencies may require fuses at the inputs of power conversion components. Fuses should also be used when there is the possibility of sustained input voltage reversal which is not current-limited. For greatest safety, we recommend a fast blow fuse installed in the ungrounded input supply line.

Vin	Fuse Recommended
24V	25A fast
48V	12A fast
72V	8A fast
110V	5A fast

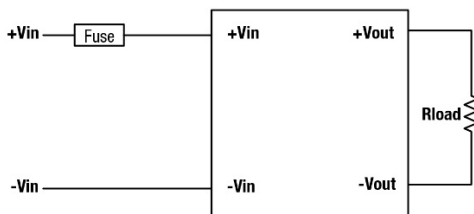

Figure 2. Input Fusing

Start-Up Time

Assuming that the output current is set at the rated maximum, the Vin to Vout Start-Up Time (see Specifications) is the time interval between the point when the rising input voltage crosses the Start-Up Threshold and the fully loaded output voltage enters and remains within its specified accuracy band. Actual measured times will vary with input source impedance, external input capacitance, input voltage slew rate and final value of the input voltage as it appears at the converter.

These converters include a soft start circuit to moderate the duty cycle of its PWM controller at power up, thereby limiting the input inrush current.

The On/Off Remote Control interval from On command to Vout (final $\pm 2\%$) assumes that the converter already has its input voltage stabilized above the Start-Up Threshold before the On command. The interval is measured from the On command until the output enters and remains within its specified accuracy band. The specification assumes that the output is fully loaded at maximum rated current. Similar conditions apply to the On to Vout regulated specification such as external load capacitance and soft start circuitry.

Recommended Input Filtering

The user must assure that the input source has low AC impedance to provide dynamic stability and that the input supply has little or no inductive content, including long distributed wiring to a remote power supply. The converter will operate with no additional external capacitance if these conditions are met.

For best performance, we recommend installing a low-ESR capacitor immediately adjacent to the converter’s input terminals. The capacitor should be a ceramic type such as the Murata GRM32 series or a polymer type. Make sure that the input terminals do not go below the undervoltage shutdown voltage at all times. More input bulk capacitance may be added in parallel (either electrolytic or tantalum) if needed.

Recommended Output Filtering

The converter will achieve its rated output ripple and noise with no additional external capacitor. However, the user may install more external output capacitance to reduce the ripple even further or for improved dynamic response. Again, use low-ESR ceramic (Murata GRM32 series) or polymer capacitors. Mount these close to the converter. Measure the output ripple under your load conditions.

Use only as much capacitance as required to achieve your ripple and noise objectives. Excessive capacitance can make step load recovery sluggish or possibly introduce instability. Do not exceed the maximum rated output capacitance listed in the specifications.

Input Ripple Current and Output Noise

All models in this converter series are tested and specified for input reflected ripple current and output noise using designated external input/output components, circuits and layout as shown in the figures below. The Cbus and Lbus components simulate a typical DC voltage bus.

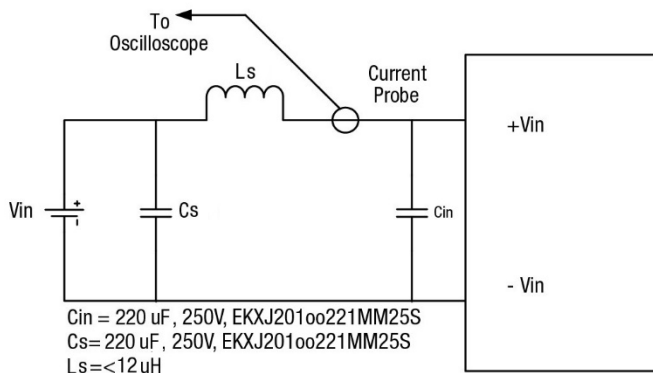

Figure 3. Measuring Input Ripple Current

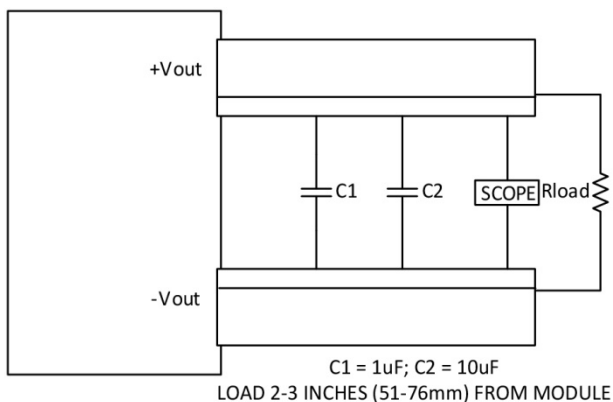

Figure 4. Measuring Output Ripple and Noise (PARD)

Output Over-Voltage Protection

The IRH-W80 output voltage is monitored for an over-voltage condition using a comparator. The signal is optically coupled to the primary side and if the output voltage rises to a level which could be damaging to the load, the sensing circuitry will disable the PWM controller drive causing the output voltage to decrease. Following a time-out period, the PWM will restart, causing the output voltage to begin rising to its appropriate value. If the Over-Voltage condition persists, another shutdown cycle will initiate. This rapid on/off cycling is called "hiccup mode".

The "hiccup" system differs from older latching circuit systems because you do not have to power down the converter to make it restart. The system will automatically restore operation as soon as the condition is removed.

Thermal Shutdown

CAUTION: If you operate too close to the thermal limits, the converter may shut down suddenly without warning. Be sure to thoroughly test your application to avoid unplanned thermal shutdown.

Temperature Derating Curves

The thermal derating curve is based on the best setup shown in Figure 5. The module is mounted on an Al plate and was cooled by resistance wire. Figure 6 shows the location to monitor the temperature of the module's baseplate. The baseplate temperature in thermal derating curve is a reference for customer to make thermal evaluation and make sure the module is operated under allowable temperature. Thermal curves shown in Figure 7 are based on different input voltages.

CAUTION: If you exceed these Derating guidelines, the converter may have an unplanned Over Temperature shut down. Also, these graphs are all collected near Sea Level altitude. Be sure to reduce the derating for higher altitude.

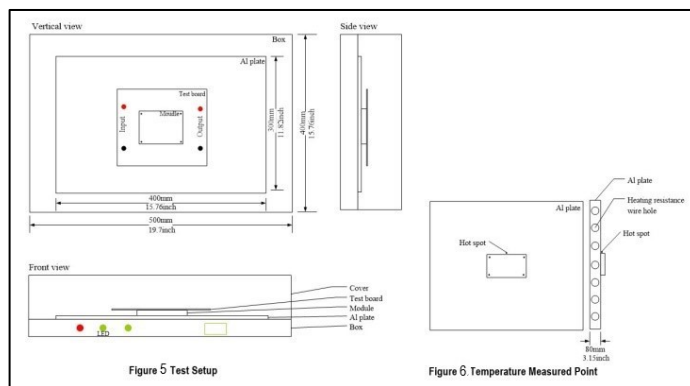

IRH-12/21-W80 Temperature Derating

(power module on 300mm*400mm*80mm aluminum plate)

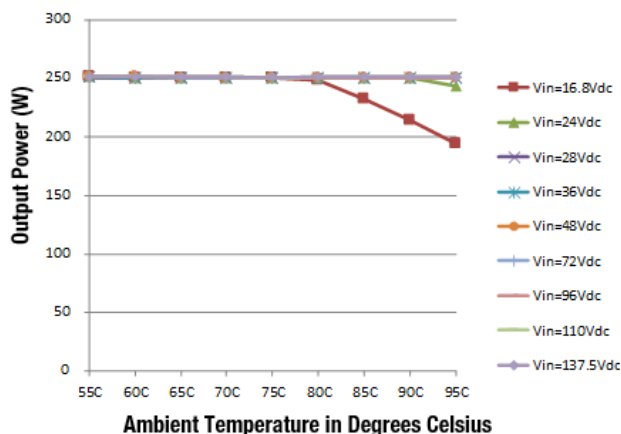

Figure 7. Derating Curves

Output Fusing

The converter is extensively protected against current, voltage and temperature extremes. However, your output application circuit may need additional protection. In the extremely unlikely event of output circuit failure, excessive voltage could be applied to your circuit. Consider using an appropriate fuse in series with the output.

Output Current Limiting & Over-Current Protection

Current limiting inception is defined as the point at which full power falls below the rated tolerance. See the Performance/Functional Specifications. Note particularly that the output current may briefly rise above its rated value in normal operation as long as the average output power is not exceeded. This enhances reliability and continued operation of your application. If the output current is too high, the converter will enter the short circuit condition. The modules include an internal output over-current protection circuit, which will endure current limiting for an unlimited duration during output overload. If the output current exceeds the OCP set point, the module will shut down, and always try to restart (hiccup mode) until the over current condition is corrected. The OCP pin is used to adjust the OCP value by connecting a resistor between OCP (PIN #6) and Vin(-)(PIN #7) if needed. The OCP pin is left floating if not used. Please see the external resistor table below.

IRH-12/21-W80, OCP (A) with External Resistor									
Vin(V)	*External Resistor (kΩ)								
	0.562	0.665	0.845	1.13	1.33	1.69	3.32	6.65	10
24	14.40	16.20	18.40	20.45	21.10	22.14	23.90	24.70	25.00
48	15.20	17.20	19.10	20.90	21.80	22.70	24.40	25.30	25.60
72	15.50	17.10	19.20	21.10	21.80	22.70	24.50	25.20	25.60
96	14.90	17.40	19.80	22.00	22.60	24.07	25.90	26.90	27.20
110	11.50	13.90	17.00	19.70	20.80	22.10	24.50	25.60	26.00

* The OCP current with different external resistor and input voltage are typical values for reference and have a tolerance of about ±2.5A.

Output Short Circuit Condition

The PWM controller will shut down at a short condition, and always try to restart (hiccup mode) until the short condition is corrected. The hiccup cycling reduces the average output current, thereby preventing excessive internal temperatures and/ or component damage.

Output Capacitive Load

These converters do not require external capacitance added to achieve rated specifications. Users should only consider adding capacitance to reduce switching noise and/or to handle spike current load steps. Install only enough capacitance to achieve noise objectives. Excess external capacitance may cause degraded transient response and possible oscillation or instability.

Remote Sense Input

Use the Sense inputs with caution. Sense is normally connected at the load. Sense inputs compensate for output voltage inaccuracy delivered at the load. This is done by correcting IR voltage drops along the output wiring and the current carrying capacity of PC board etch. Sense inputs also improve the stability of the converter and load system by optimizing the control loop phase margin.

NOTE: The Sense input and power Vout lines are internally connected through low value resistors to their respective polarities so that the converter can operate without external connection to the Sense. Nevertheless, if the Sense function is not used for remote regulation, the user should connect +Sense to +Vout and -Sense to -Vout at the converter pins.

The remote Sense lines carry very little current. They are also capacitively coupled to the output lines and therefore are in the feedback control loop to regulate and stabilize the output. As such, they are not low impedance inputs and must be treated with care in PC board layouts. Sense lines on the PCB should run adjacent to DC signals, preferably Ground. In cables and discrete wiring, use twisted pair, shielded tubing or similar techniques.

Any long, distributed wiring and/or significant inductance introduced into the Sense control loop can adversely affect overall system stability. If in doubt, test your applications by observing the converter’s output transient response during step loads. There should not be any appreciable ringing or oscillation. You may also adjust the output trim slightly to compensate for voltage loss in any external filter elements. Do not exceed maximum power ratings.

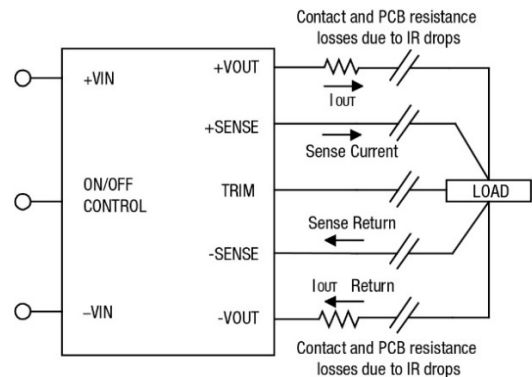

Figure 8. Remote Sense Circuit Configuration

$$[V_{out(+)} - V_{out(-)}] - [Sense(+)-Sense(-)] \leq \text{Output Sense Range}$$

Vo	12V	24V	54V
Output Sense Range	10%	5%	4%

Output overvoltage protection is monitored at the output voltage pin, not the Sense pin. Therefore, excessive voltage differences between Vout and Sense together with trim adjustment of the output can cause the overvoltage protection circuit to activate and shut down the output. Power derating of the converter is based on the combination of maximum output current and the highest output voltage. Therefore, the designer must ensure: (Vout at pins) x (Iout) ≤ (Max. rated output power)

Trimming the Output Voltage

The Trim input to the converter allows the user to adjust the output voltage over the rated trim range (please refer to the Specifications). In the trim equations and circuit diagrams that follow, trim adjustments use either a trimpot or a single fixed resistor connected between the Trim input and either the +Sense or -Sense terminals. Trimming resistors should have a low temperature coefficient (± 100 ppm/deg.C or less) and be mounted close to the converter. Keep leads short. If the trim function is not used, leave the trim unconnected. With no trim, the converter will exhibit its specified output voltage accuracy.

There are two CAUTIONs to observe for the Trim input:

CAUTION: To avoid unplanned power down cycles, do not exceed EITHER the maximum output voltage OR the maximum output power when setting the trim. Be particularly careful with a trimpot. If the output voltage is excessive, the OVP circuit may inadvertently shut down the converter. If the maximum power is exceeded, the converter may enter current limiting. If the power is exceeded for an extended period, the converter may overheat and encounter overtemperature shut down.

CAUTION: Be careful of external electrical noise. The Trim input is a sensitive input to the converter’s feedback control loop. Excessive electrical noise may cause instability or oscillation. Keep external connections short to the Trim input. Use shielding if needed.

Trim Equations

Trim Equations		
Model	Rt_up (kΩ)	Rt_down (kΩ)
IRH-12/21-W80	$V_o * (1 - 0.102) / (V_o * 0.102 - 1.225)$	$1 / (1.225 / 0.102 / V_o - 1)$
IRH-24/10.5-W80	$V_o * (1 - 0.051) / (V_o * 0.051 - 1.225)$	$1 / (1.225 / 0.051 / V_o - 1)$

	Trim up			Trim down		
	V _o	12.6V (5%)	13.2V (10%)	11.4V (-5%)	10.8V (-10%)	9.6V (-20%)
IRH-12/21-W80	Trim-Sense+	188k	97k	NA	NA	NA
	Trim-Sense-	NA	NA	18.7k	8.9k	4k
	V _o	25.2V (5%)	26.4V (10%)	22.8V (-5%)	21.6V (-10%)	19.2V (-20%)
IRH-24/10.5-W80	Trim-Sense+	391k	205k	NA	NA	NA
	Trim-Sense-	NA	NA	19k	9k	4k

Trim Circuits

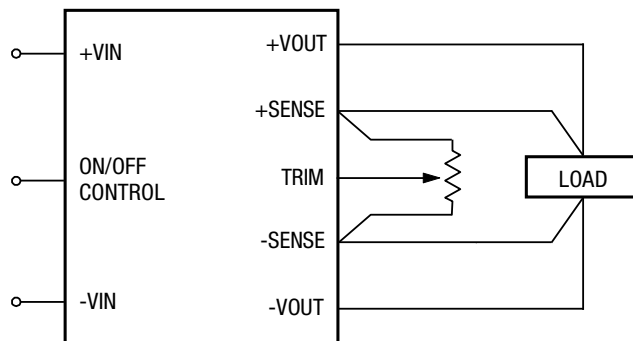

Figure 9. Trim Connections Using a Trimpot

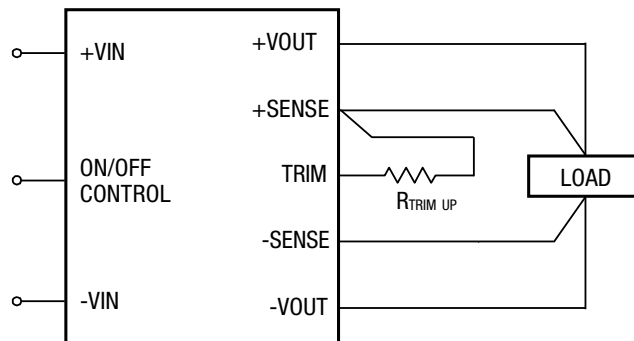

Figure 10. Trim Connections to Increase Output Voltage

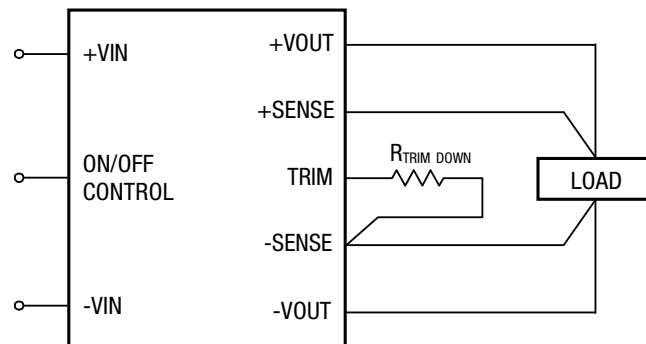

Figure 11. Trim Connections to Decrease Output Voltage

Do not exceed the specified trim range or maximum power ratings when adjusting trim. Use 1% precision resistors mounted close to the converter on short leads. If sense is not installed, connect the trim resistor to the respective Vout pin.

PULSE OUT

This pin outputs a 1kHz 50% duty cycle pulse voltage with 12V amplitude. It is designed to provide a bootstrap signal for the input inrush current limit circuit, and also could indicate operating status with a LED connected. Please leave the PULSE OUT pin open if not required.

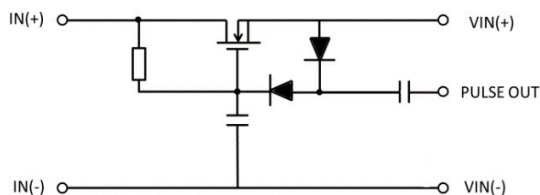

Figure 12. Active Circuit Design for Inrush Current Limit

UVLO

The IRH-W80 Series converters have an under voltage lockout feature that will shut down the converter if the input voltage falls below the adjustable threshold. Devices will automatically restart when input voltage rises above the UVLO threshold. The hysteresis built into this function prevents an indeterminate on/off condition at a single input voltage. The under voltage threshold is determined by the value of a resistor placed between the UVLO and VIN (-). Figure 13 shows a typical configuration.

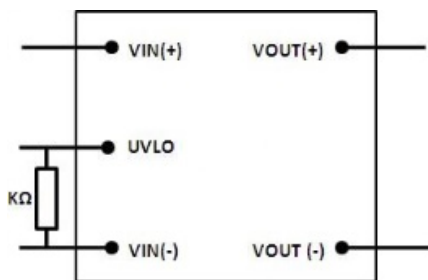

Figure 13. Under Voltage Lockout Configuration

The table below shows the UVLO values for various nominal input voltages and the required resistor values for each.

Nominal Vin	24V	36V	48V	72V	96V	110V
External Resistor (kΩ)	open	27.4	13	6.81	4.32	3.57
Turn-on Threshold	14.5 ±0.5V	22.8 ±0.5V	32.7 ±0.5V	49.5 ±1.5V	70.25 ±2V	82.08 ±2V
Turn-off Threshold	11.5 ±0.5V	18.7 ±0.5V	26.9 ±0.5V	40.5 ±1.5V	57.48 ±2V	65.04 ±2V

Hold-up Time

The BUS pin is for the hold-up time function. It is designed to work with an external circuit that is comprised of a hold-up cap (C_{hold}), a resistor (R) and a diode (D). The hold-up time is defined as the duration of time that the DC-DC converter output will remain active following a loss of input power. When this function is activated, the IRH-W80 uses the energy stored in the external hold-up circuit to support operation.

NOTE: A 100µF (C_{in}) and 240µF (C_{bus}) are required for normal operation.

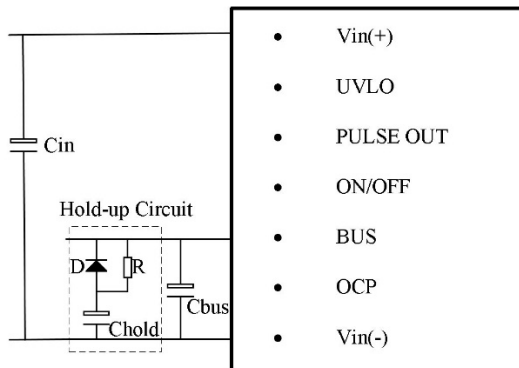

Figure 14. Connection of External Hold-up Circuit

The hold-up function provides energy that maintains the DC-DC converter in operation for 10mS, 20mS or 30mS of hold-up time. The recommended value of the hold-up capacitor (C_{hold}) is shown in the table below.

IRH-12/21-W80						
C _{hold}	24Vin	36Vin	48Vin	72Vin	96Vin	110Vin
For 10 mS	2200uF	2200uF	2200uF	2200uF	1100uF	700uF
For 20 mS	4400uF	4400uF	4400uF	4400uF	2200uF	1400uF
For 30 mS	6600uF	6600uF	6600uF	6600uF	3300uF	2100uF

Through-Hole Soldering Guidelines

Murata Power Solutions recommends the TH soldering specifications below when installing these converters. These specifications vary depending on the solder type. Exceeding these specifications may cause damage to the product. Your production environment may differ; therefore, please thoroughly review these guidelines with your process engineers.

Wave Solder Operations for Through-Hole mounted products (THMT)	
For Sn/Ag/Cu based solders:	
Maximum Preheat Temperature	115° C.
Maximum Pot Temperature	270° C.
Maximum Solder Dwell Time	7 seconds
For Sn/Pb based solders:	
Maximum Preheat Temperature	105° C.
Maximum Pot Temperature	250° C.
Maximum Solder Dwell Time	6 seconds

Qualification Tests

Parameters	Test Conditions	Operating
Vibration	EN 61373:1999 Category I, Class B, Body mounted	Yes
Mechanical Shock	EN 61373:1999 Category I, Class B, Body mounted	Yes
Temperature Cycling Test (TCT)	-40°C to 125°C, unit temp. ramp 15°C/min., 500 cycles	Yes
Temperature, Humidity and Bias (THB)	85°C, 85RH, Vin=max, Load=min load, 1072 hours (72hours with a pre-conditioning soak, unpowered)	No
Damp heat test, cyclic	EN60068-2-30: Temperature +55°C and +25°C; Number of cycles 2 (respiration effect); Time 2 x 24 hours; Relative Humidity 95%	No
Dry heat test	EN60068-2-2, Vin=nom, Full load, 85°C for 6 hours	Yes
Low Temperature Operating	Vin=nom, Full load, -40°C for 2 hours	Yes
Highly Accelerated Life Test (HALT)	High temperature limits, low temperature limits, Vibration limits, Combined Environmental Tests.	Yes
EMI	CISPR 22 Class A, or IEC62236-3-2 (GB/T 24338.4)	Yes
Surge Protection	EN50121-3-2	Yes
Solderability	MIL-STD-883, method 2003 (IPC/EIA/JEDEC J-SID-002B)	No

Conducted Emissions Test Results

Vin = 110V, Line L

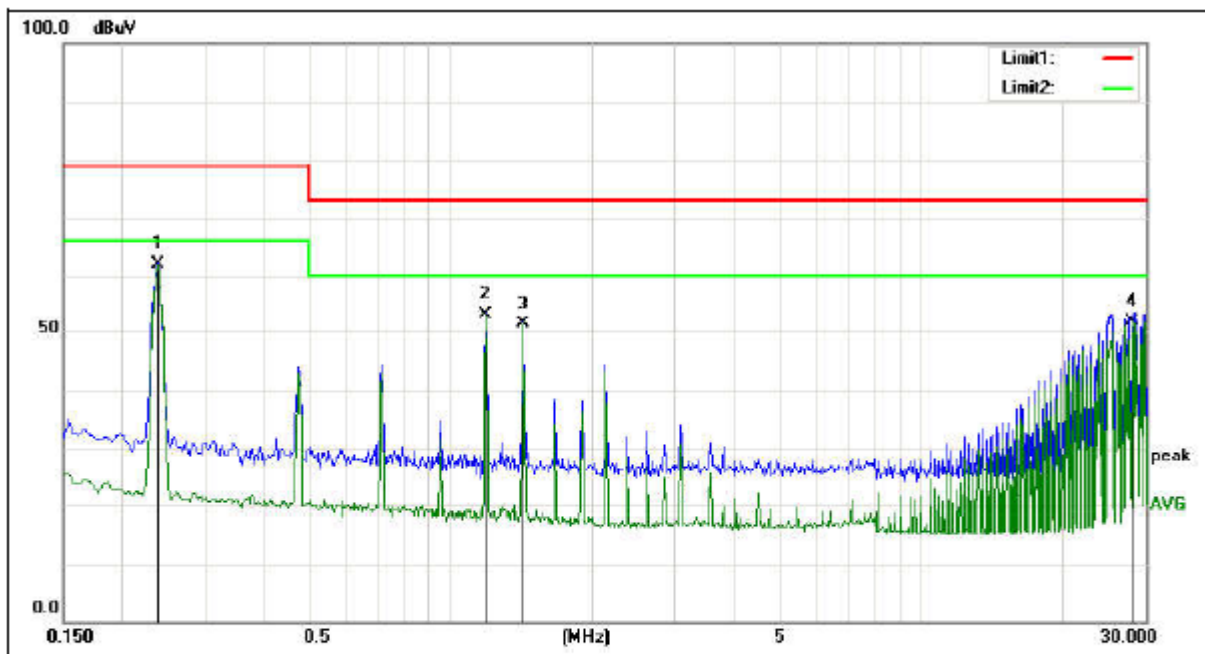

No.	Frequency (MHz)	Reading (dBuV)	Correct Factor(dB)	Result (dBuV)	Limit (dBuV)	Margin (dB)	Remark
1	0.2380	42.32	19.57	61.89	66.00	-4.11	AVG
2	1.1900	33.46	19.64	53.10	60.00	-6.90	AVG
3	1.4260	31.80	19.65	51.45	60.00	-8.55	AVG
4	28.0420	31.96	19.97	51.93	60.00	-8.07	AVG

EMI Filter, Schematic & Parts List

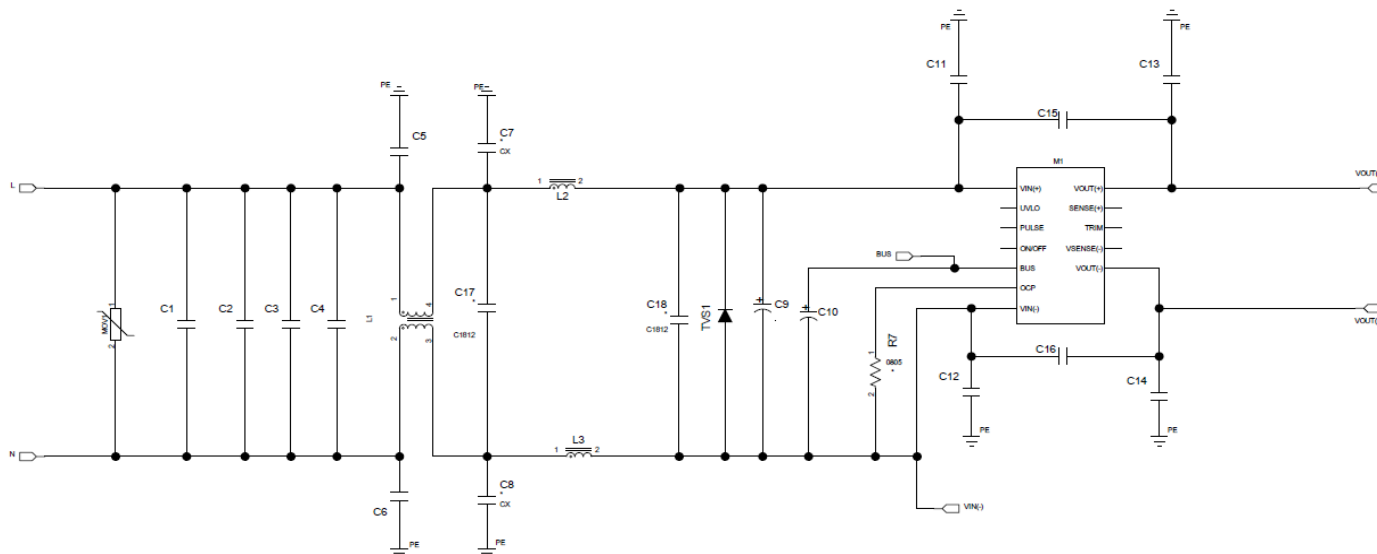

Reference	Manufacturer	MPN	Type	Specifications	Qty
MOV1	Epcos	B72214S0141K101	Varistor	180V, 36J	1
TVS1	Littell Fuse	1.5KE220A	TVS diode	185V, 1.5KW	1
C1	Faratronic	C212E475K9AC000	Polyester capacitor	250V, 4.7uF	1
C2, C3, C4	Murata	GRM43DR72E474KW01L	Capacitor MLCC	250V, 0.47uF	3
C5, C6, C11, C12, C13, C14	Murata	DE1E3RA102MA4BQ01F	Safety ceramic cap	500V, 1000pF	6
C9, C10	NCC	EKXJ251EXX271ML40S	E-cap	250V, 270uF	2
C15, C16	Murata	DE1E3RA472MA4BQ01F	Safety ceramic cap	500V, 4700pF	2
L1	Würth	7448262013	CM choke	1.3mH, 20A	1
L2, L3	Bourns	2300HT-220-V-RC1951	DM choke	22uH, 19A	2
C7, C8	NA	NOT USED	NA	NA	0
C17, C18	NA	NOT USED	NA	NA	0

NOTICE: Please use only this customer data sheet as product documentation when laying out your printed circuit boards and applying this product into your application. Do NOT use other materials as official documentation such as advertisements, product announcements, or website graphics.

We strive to have all technical data in this customer data sheet highly accurate and complete. This customer data sheet is revision-controlled and dated. The latest customer data sheet revision is normally on our website (www.murata-ps.com) for products which are fully released to Manufacturing. **Please be especially careful using any data sheets labeled "Preliminary" since data may change without notice.**

Murata Power Solutions, Inc.
129 Flanders Rd., Westborough, MA 01581 USA
ISO 9001 and 14001 REGISTERED



This product is subject to the following [operating requirements](#) and the [Life and Safety Critical Application Sales Policy](#): Refer to: <http://www.murata-ps.com/requirements/>

Murata Power Solutions, Inc. makes no representation that the use of its products in the circuits described herein, or the use of other technical information contained herein, will not infringe upon existing or future patent rights. The descriptions contained herein do not imply the granting of licenses to make, use, or sell equipment constructed in accordance therewith. Specifications are subject to change without notice. © 2020 Murata Power Solutions, Inc.