

May 2020

Samsung MLCCs for Automotive



To ensure safe drive



SAMSUNG
ELECTRO-MECHANICS



The Solution Provider to realize Eco-friendly Smart Mobility

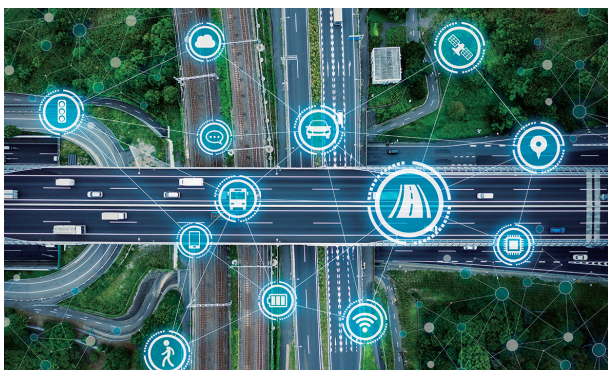

Electric has improved with main three keywords: “Eco-friendly, Stability and Convenience”, which plays a pivotal role in the recent trend of the automobile industry, so that it will appear an eco-friendly autonomous vehicle at the end.

The trend of automobile has been changed to realize four keywords: “Connected” that connects everything to a car by combining IT technology, “Autonomous” that allows a car to achieve automatic self-driving without driver’s maneuver, “Sharing” that shares a car with many people by an hour, and “Electric” that transforms car’s engine from an internal combustion engine to an electric motor to reduce emissions from a car.

An increasing ratio of electric has led to a greater use of MLCC. Therefore, MLCC is required for high reliability in the automobile industry, with

considering poor outdoor environment and long-term operating condition.

In particular, if ECU (Electronic Control Unit), unlike IT devices such as a smartphone, a repeater and etc, causes a malfunction, it could result in life damage. In order to prevent such serious damage, ECU should be equipped with reliable fault tolerance.

Therefore, MLCC, being used as a major part of ECU, requires an accurate and detailed master plan for every single stage including design and process and outgoing inspection to prevent malfunctions in MLCC even in a vulnerable environment. Samsung Electro-Mechanics has developed products with high reliability to be necessary for automotive electronics based on our accumulated technology.

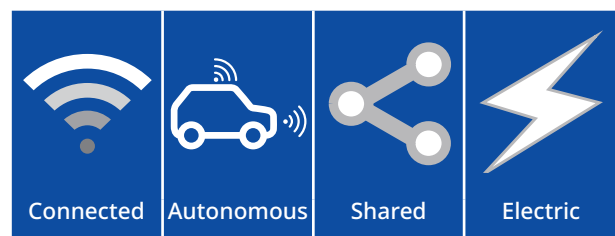

Automotive industry megatrends



Electric

The Electric of automobile has led to an increasing use of an electronic system rapidly. To keep up with the trend, Samsung Electro-Mechanics has developed ultra-small size and ultra-high- capacitance products to satisfy the needs of customers in the automobile industry. A malfunction in MLCC for Electric is considered as life-threatening, requiring to ensure high reliability and durability. Therefore, MLCC should be equipped with longer lifespan and more refined technique compared to IT equipment.

High specification Electric-type MLCC should operate properly in a considerably tough environment such as a high temperature (above 150°C), a low temperature (-55°C), high humidity (85%) and bending by vibrations and shocks and so on.

To deal with such a tough test environment, we have products with a ceramic material technique to stand a high temperature and a high voltage, which a micro-structural design technique is used for the products to enhance vibrations and moisture resistance. These components are designed to stand temperatures, vibrations and shocks of electric unit, helping work out a power electronics system properly where high reliability is required in a tough environment.

Use :

PCU (Power Control Unit)

OBC (On Board Charger)

BMS (Battery Management System)

DC-DC (High Voltage to 12V)



Autonomous

As for Autonomous, sensors detect the surroundings of vehicles, Electronic Control Unit (ECU) which plays a role of a brain like human determines driving strategies and controls automobile parts. Advanced MLCC to be used for autonomous is a core part to secure 'safety'. We have put efforts to develop products that operate properly in a tough environment such as a high temperature(approximately 150°C), a high humidity (85%), applying to ECU that has a significant effect on driver's safety as a core part of an autonomous vehicle, a cruise control, an airbag system and etc. We have expanded a type of small size-high capacitance and Low ESL products to keep up with high performance products such as camera, radar, GPS, SoC and GPU IC, which is a great contributor to lead the core trend in autonomous.



Use :

- SCC (Smart Cruise Control)
- LiDAR (Light Detection And Ranging)
- NVS (Night Vision System)
- Autonomous Control Unit



Connected

A connected car is available for network connectivity, allowing automobiles to interconnect with internal and external networks via wireless communication to enhance driver convenience.

The automobile industry combines Information Communication Technology (ICT) such as the Internet and mobile devices with automobiles, leading to advanced automobile functions and increasing a demand for electronic components consisting of a high quality communication network.

We offer optimal high-performance and high-reliability electronic components to realize a smooth communication environment in the automobile so that the connected car consisting of In-Vehicle Infotainment (IVI), Advanced Driver Assistance System (ADAS), and Autonomous Vehicle (AV) can deliver an optimal driver-friendly environment through connectivity and communication with the internal and external vehicle environment.

We will serve the advancement of the automobile communication technology by providing advanced MLCC products which are designed to extend its lifespan and prevent short circuits based on optimal soft-termination technology that is our confidence in the automobile communication industry.

Use :

- TCU (Telematics Control Unit)
- IVI (In-Vehicle Infotainment)
- AVN (Audio-Video-Navigation)

Key Applications

Inverter

(Main Motor Driver)

EV

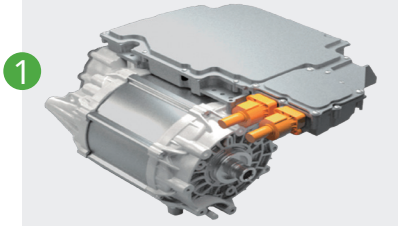

P07

BMS

(Battery Management System)

EV

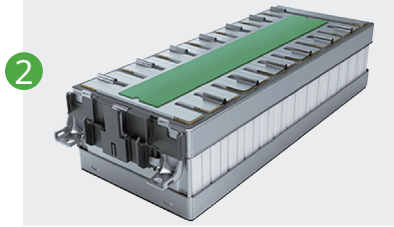

P09

OBC

(On Board Charger)

EV

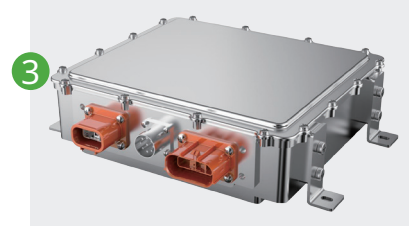

P08

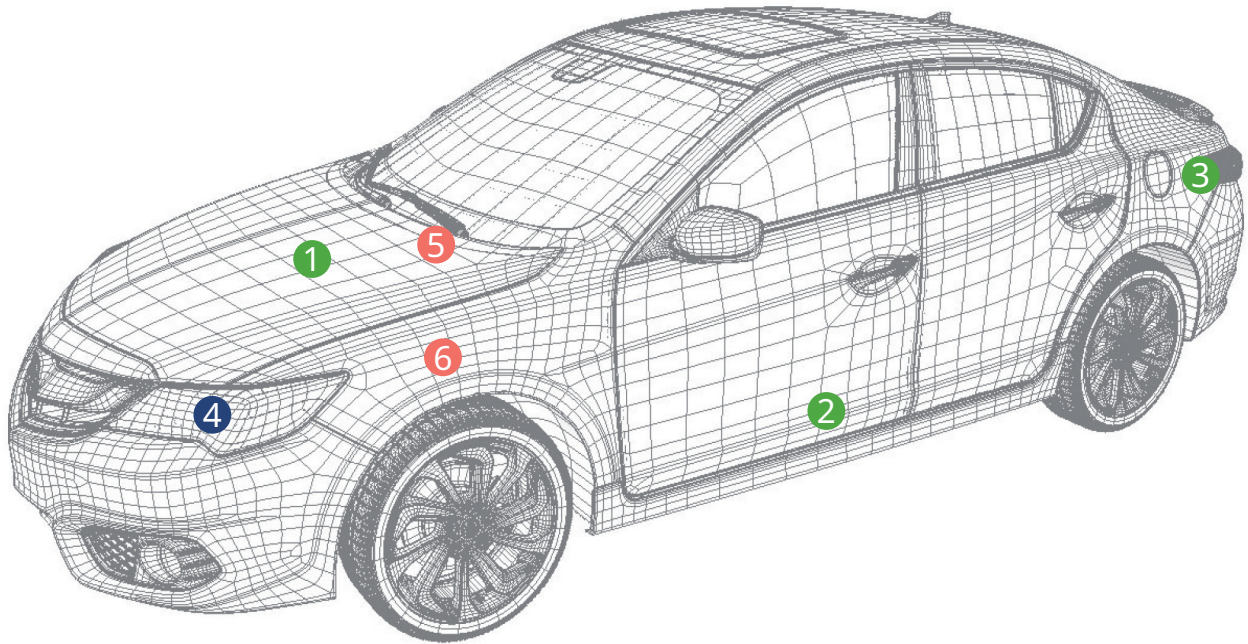

Lighting

(LED Light Module with AFLS)

Body



P16

EPS

(Electric Power Steering)

Chassis



P15

BAU

(Brake Actuation Unit)

Chassis



P14

Key Applications

SCC

(Smart Cruise Control)

ADAS

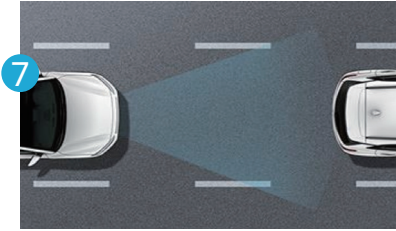

P22

ACU

(Autonomous Control Unit)

ADAS

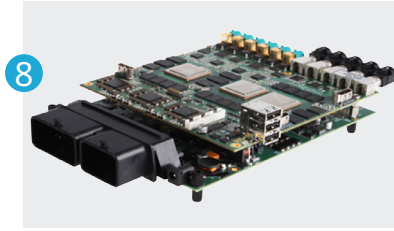

P25

Head Unit

(for Audio-Video-Navigation)

IVI



P19

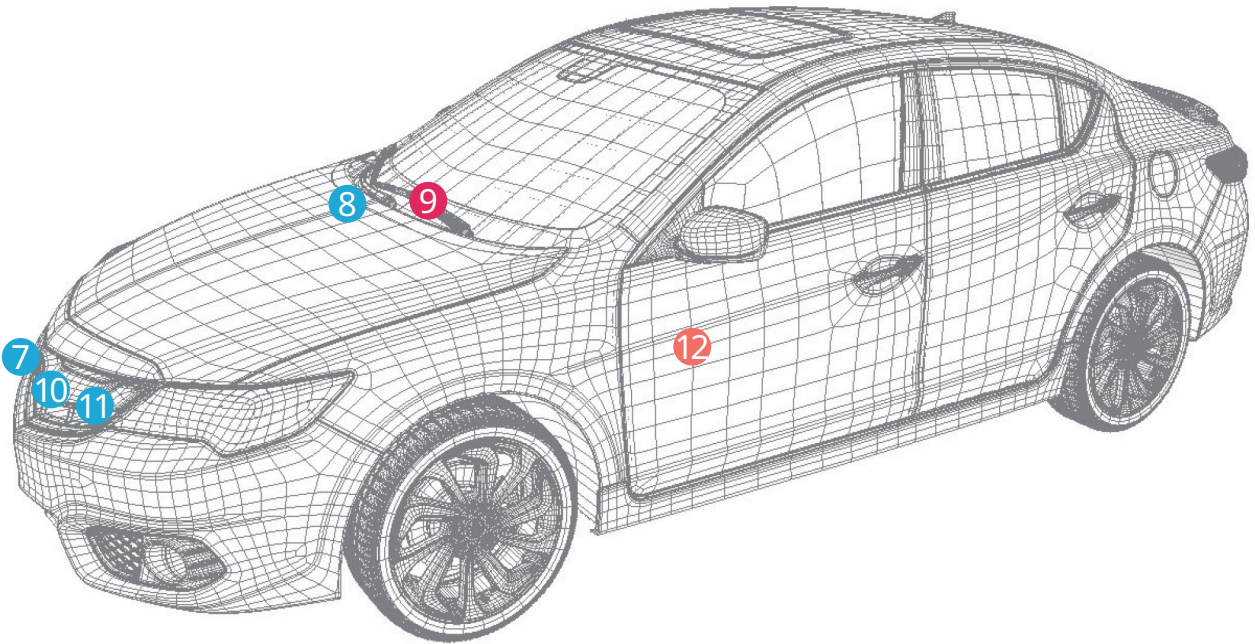

LiDAR

(Light Detection And Ranging)

ADAS

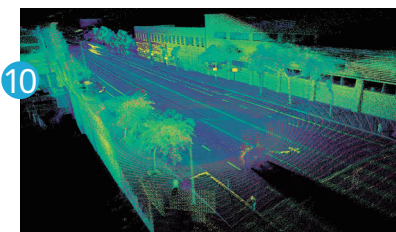

P23

NVS

(Night Vision System)

ADAS

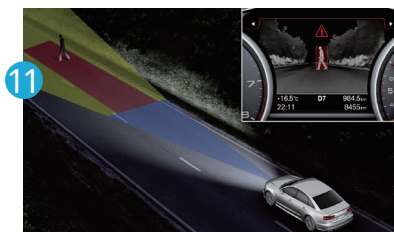

P24

ACU

(Airbag Control Unit)

Chassis



P13

Application Guides

Automotive

xEV

Safety

Infotainment

Powertrain

ADAS

Comfort

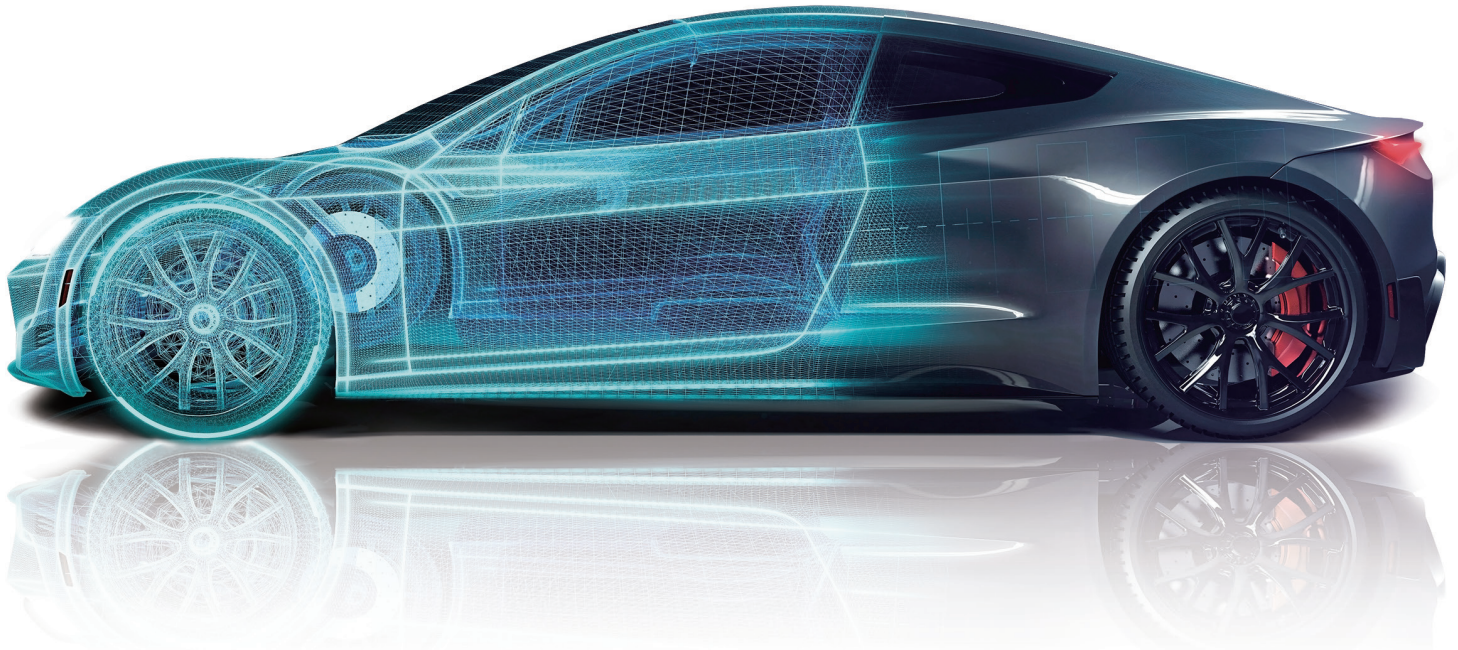

Inverter **BMS** LDC **OBC** Engine ECU Transmission ECU

Headlamp ACU **TPMS** ABS/ESC **LDWS/LKAS** **LiDAR**

Radar Night View **Autonomous Driving** **Parking Assist**

HUD Digital Cluster **AVN** **EPS** Keyless Entry WPT

Main Inverter

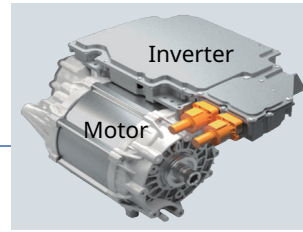

A Main Inverter provides energy to the vehicle's driving motor.

The main inverter directly uses a high voltage battery power through a DC-Link capacitor and performs improvement of the fuel economy of the vehicle by absorbing energy through a regenerative braking function.

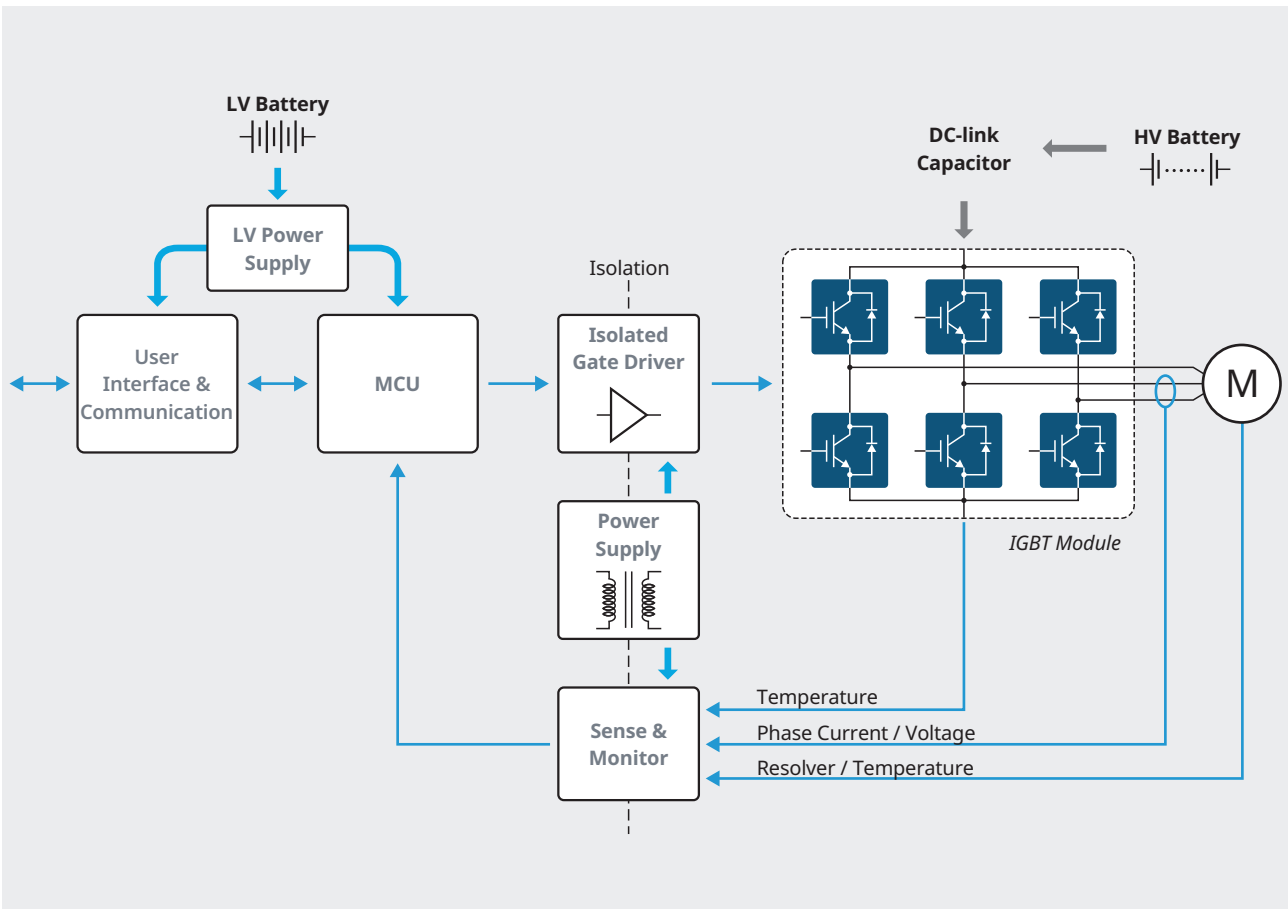

Normal (All Location)

X7* Normal(Epoxy)

PN Series

COG Normal

PN Series

Crack Mitigation (12V Battery Line, Near Hole & Connector)

Soft Termination

*PJ Series

Fail Safe/Soft Term.

XPJ Series

ESD Strengthen (Connector I/F)

ESD Strengthen

PE Series

On Board Charger

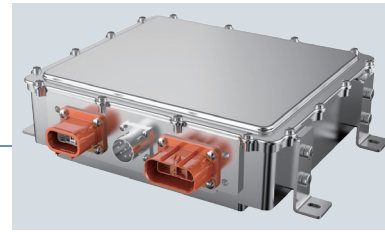

An On-Board Charger (OBC) is a built-in system to charge a high voltage battery from AC power outside the car. OBC allows a vehicle for a standard charge at a charging station as well as at home.

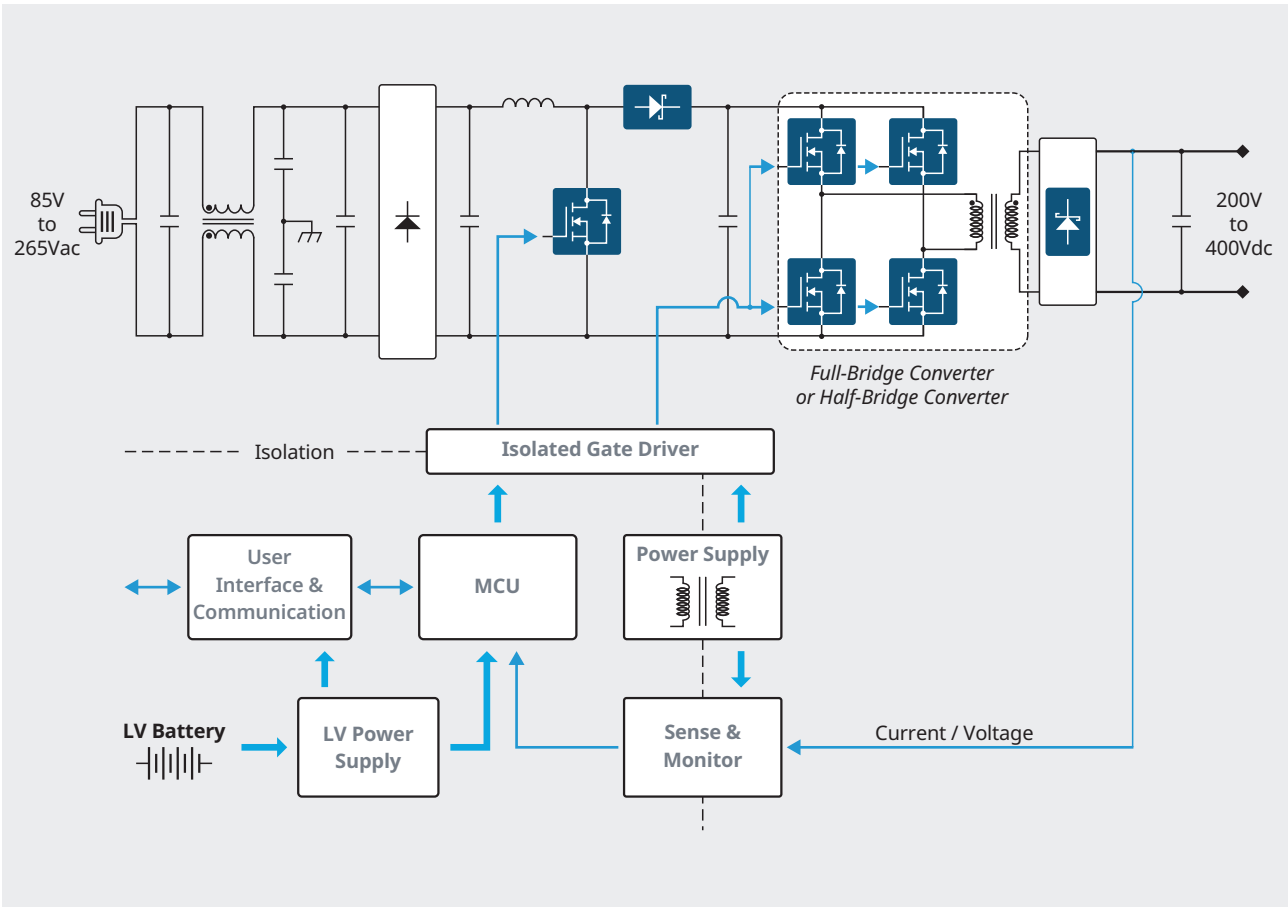

Samsung MLCCs for Automotive

Normal
(All Location)

X7* Normal(Epoxy)

PN Series

COG Normal

PN Series

Crack Mitigation
(12V Battery Line,
Near Hole & Connector)

Soft Termination

*PJ Series

Fail Safe/Soft Term.

XPJ Series

ESD Strengthen
(Connector I/F)

ESD Strengthen

PE Series

Battery Management System

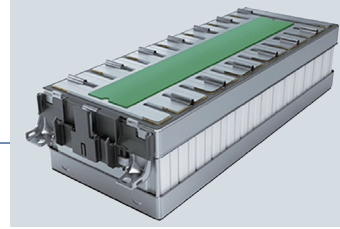

A Battery Management System (BMS) is the control system that manages a high voltage battery built with numerous cells, monitoring and controlling temperatures and voltage of the each cell.

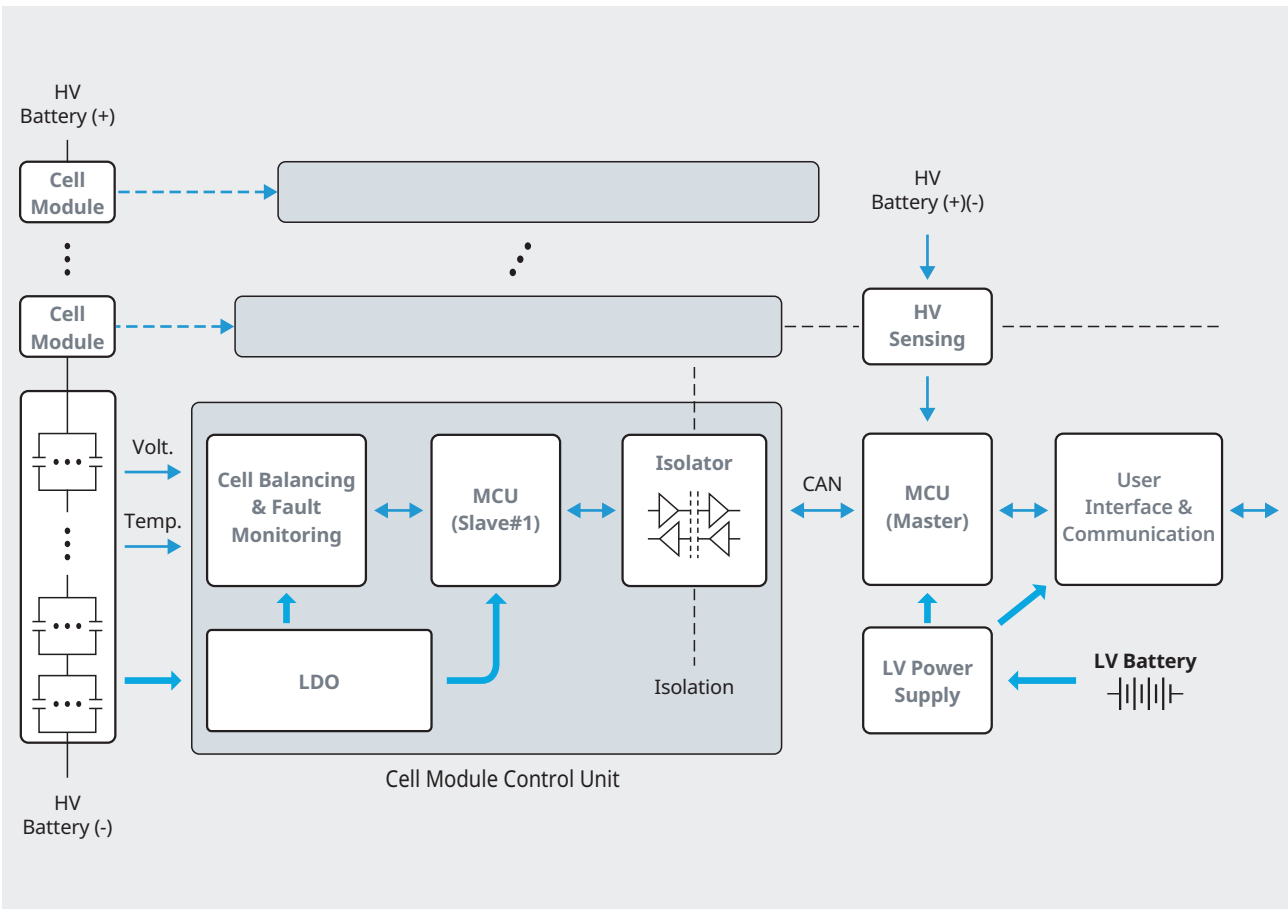

Samsung MLCCs for Automotive

Normal
(All Location)

X7* Normal(Epoxy)

PN Series

COG Normal

PN Series

Crack Mitigation
(12V Battery Line,
Near Hole & Connector)

Soft Termination

*PJ Series

Fail Safe/Soft Term.

XPJ Series

ESD Strengthen
(Connector I/F)

ESD Strengthen

PE Series

DC-DC Converter (High Voltage to 12V)

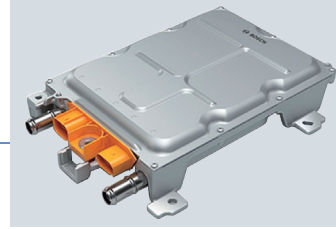

A DC-DC Converter converts a high voltage battery into a 12V battery. As there is no engine using fossil fuels, the DC-DC Converter plays a role in charging a 12V battery as an alternator used the engine to charge a 12V battery.

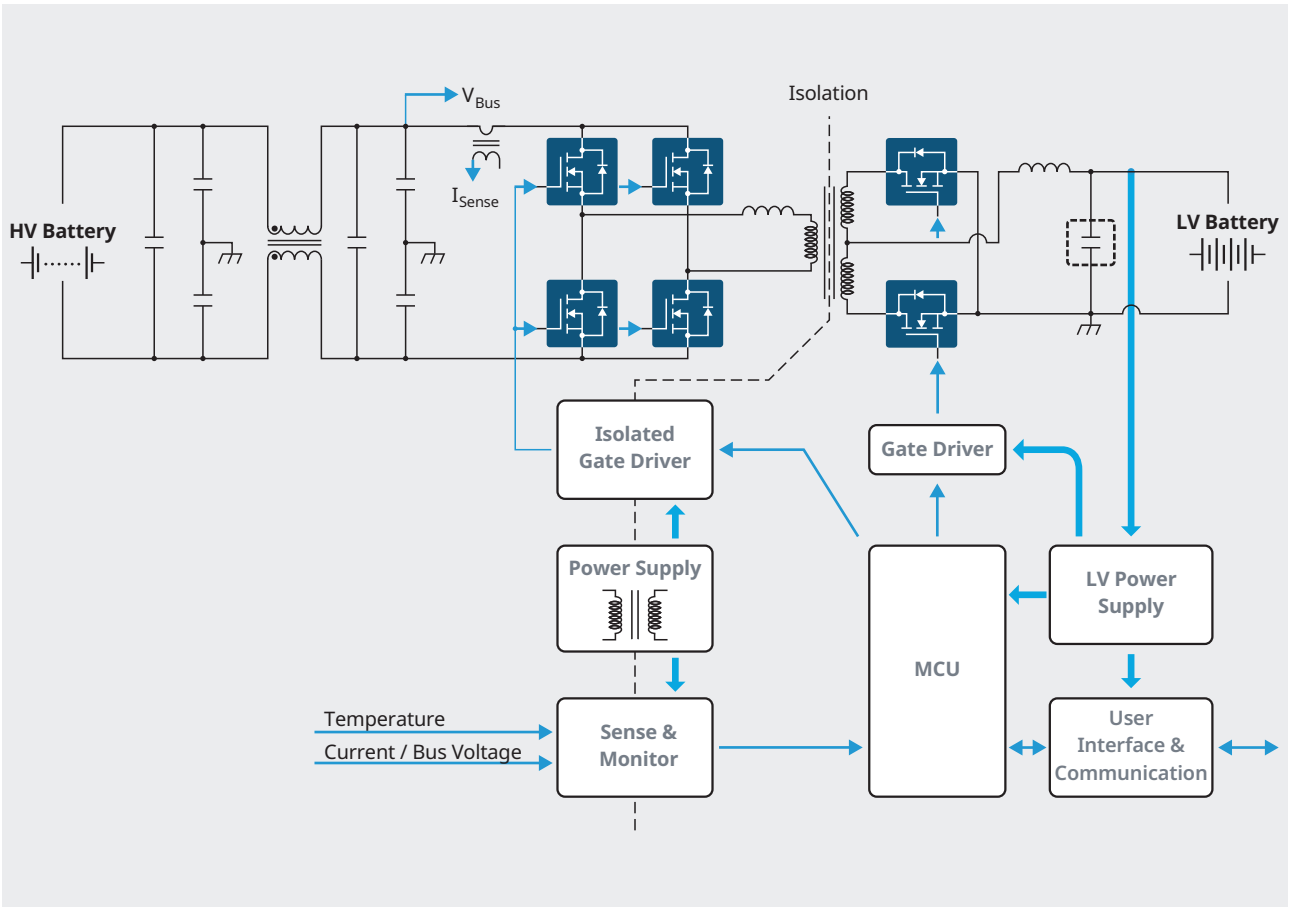

Samsung MLCCs for Automotive

Normal
(All Location)

X7* Normal(Epoxy)

PN Series

COG Normal

PN Series

Crack Mitigation
(12V Battery Line,
Near Hole & Connector)

Soft Termination

*PJ Series

Fail Safe/Soft Term.

XPJ Series

ESD Strengthen
(Connector I/F)

ESD Strengthen

PE Series

Engine Control Unit

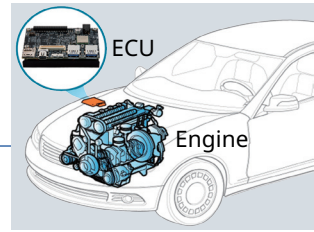

An Engine Control Unit (ECU) is a type of electronic control unit that provides the power with a series of actuators on an engine.

It is becoming increasingly significant to reduce gas emission and improve fuel efficiency by the stricter global environmental regulation. Regarding the situation, ECU collects data from various sensors on an engine, controlling its components in the unit.

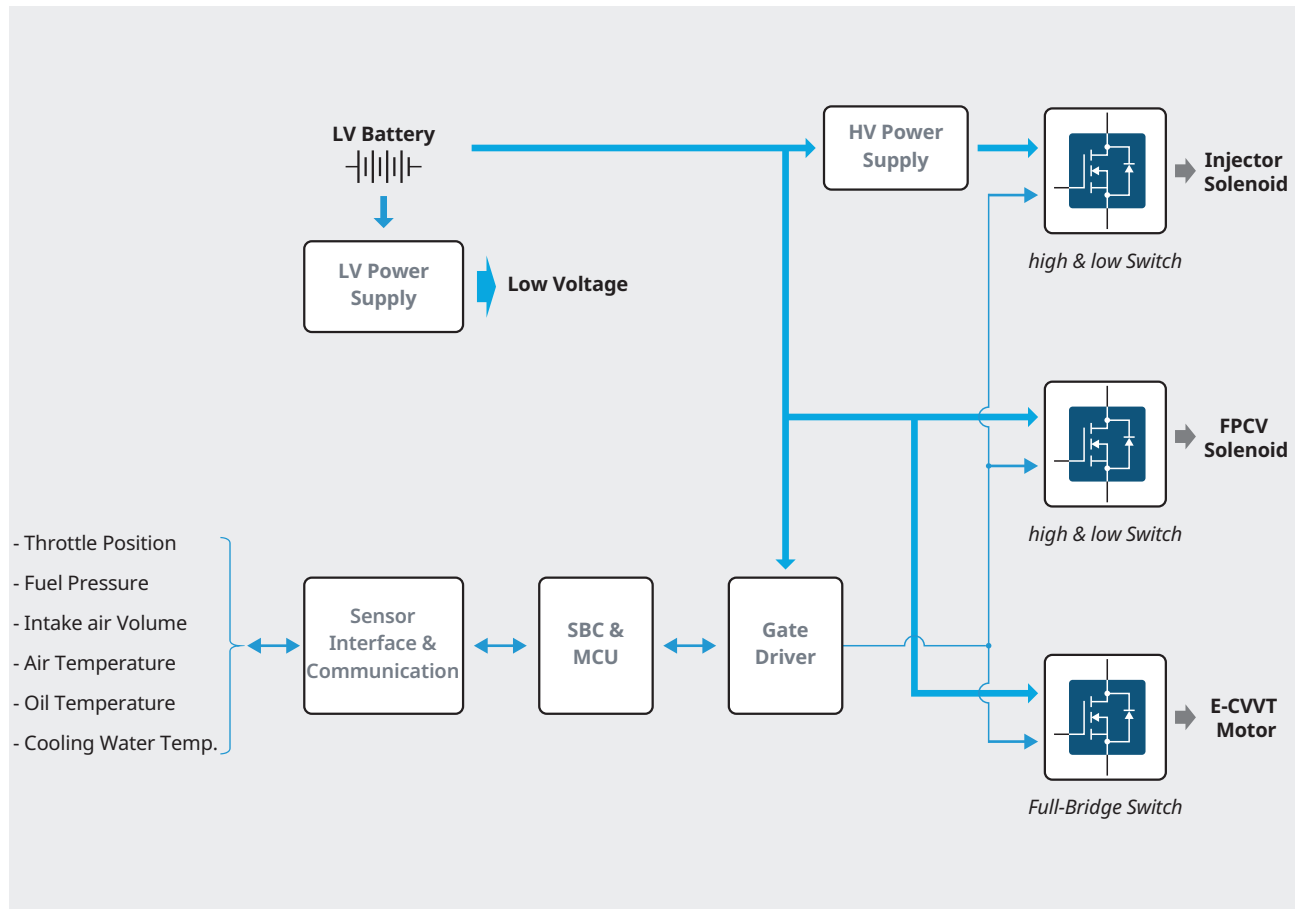

Samsung MLCCs for Automotive

Normal
(All Location)

X7* Normal(Epoxy)

PN Series

COG Normal

PN Series

Crack Mitigation
(12V Battery Line,
Near Hole & Connector)

Soft Termination

*PJ Series

Fail Safe/Soft Term.

XPJ Series

ESD Strengthen
(Connector I/F)

ESD Strengthen

PE Series

High Temperature
(near Power Semiconductor)

X8* Normal

PN Series

Transmission Control Unit

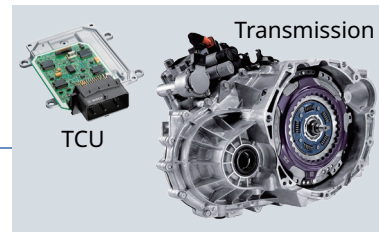

A transmission is an automatic device that transmits output torque from a crank shaft on an engine to wheels. TCU controls determines the ratio of a transmission, controlling its unit to transmit the ratio. As TCU is getting closer to the transmission to reduce price and weight for the transmission system, an operating temperature of TCU is getting increasing.

Samsung MLCCs for Automotive

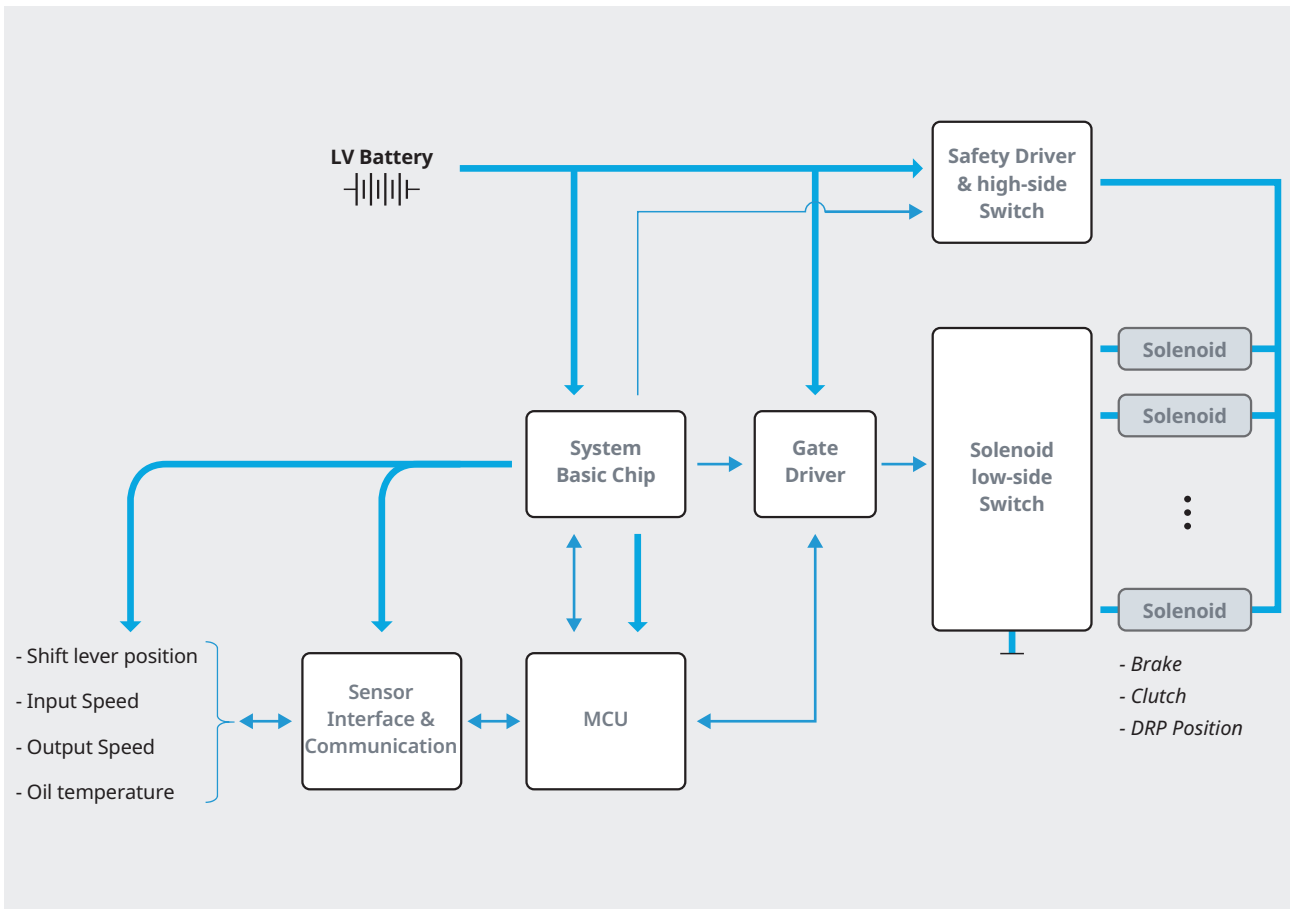

Normal
(All Location)

X7* Normal(Epoxy)

PN Series

COG Normal

PN Series

Crack Mitigation
(12V Battery Line,
Near Hole & Connector)

Soft Termination

*PJ Series

Fail Safe/Soft Term.

XPJ Series

ESD Strengthen
(Connector I/F)

ESD Strengthen

PE Series

High Temperature
(near Power Semiconductor)

X8* Normal

PN Series

Airbag Control Unit



An Airbag Control Unit (ACU) determines whether to run restraint systems according to the level of an accident being detected by an Airbag Control Unit. Acceleration sensor and speed sensor are embedded in an airbag system.

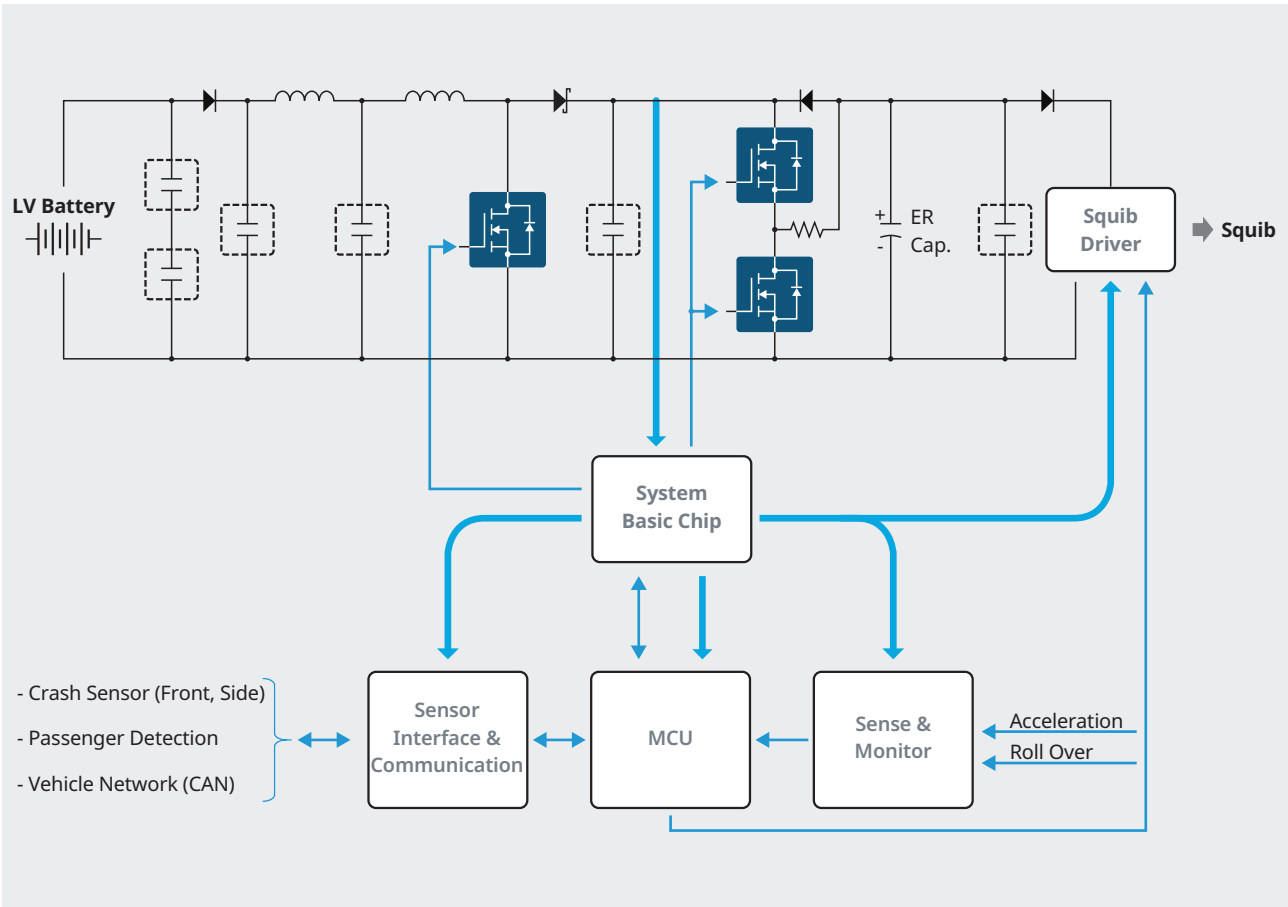

Samsung MLCCs for Automotive

Normal
(All Location)

X7* Normal(Epoxy)

PN Series

COG Normal

PN Series

Crack Mitigation
(12V Battery Line,
Near Hole & Connector)

Soft Termination

*PJ Series

Fail Safe/Soft Term.

XPJ Series

ESD Strengthen
(Connector I/F)

ESD Strengthen

PE Series

Brake Actuation Unit



A Brake Actuation Unit is an integrated control system including functions of an integrated active hydraulic booster and Electronic Stability Control (ESC). BAU provides hydraulic pressure to brake calipers to control braking force on the vehicle.

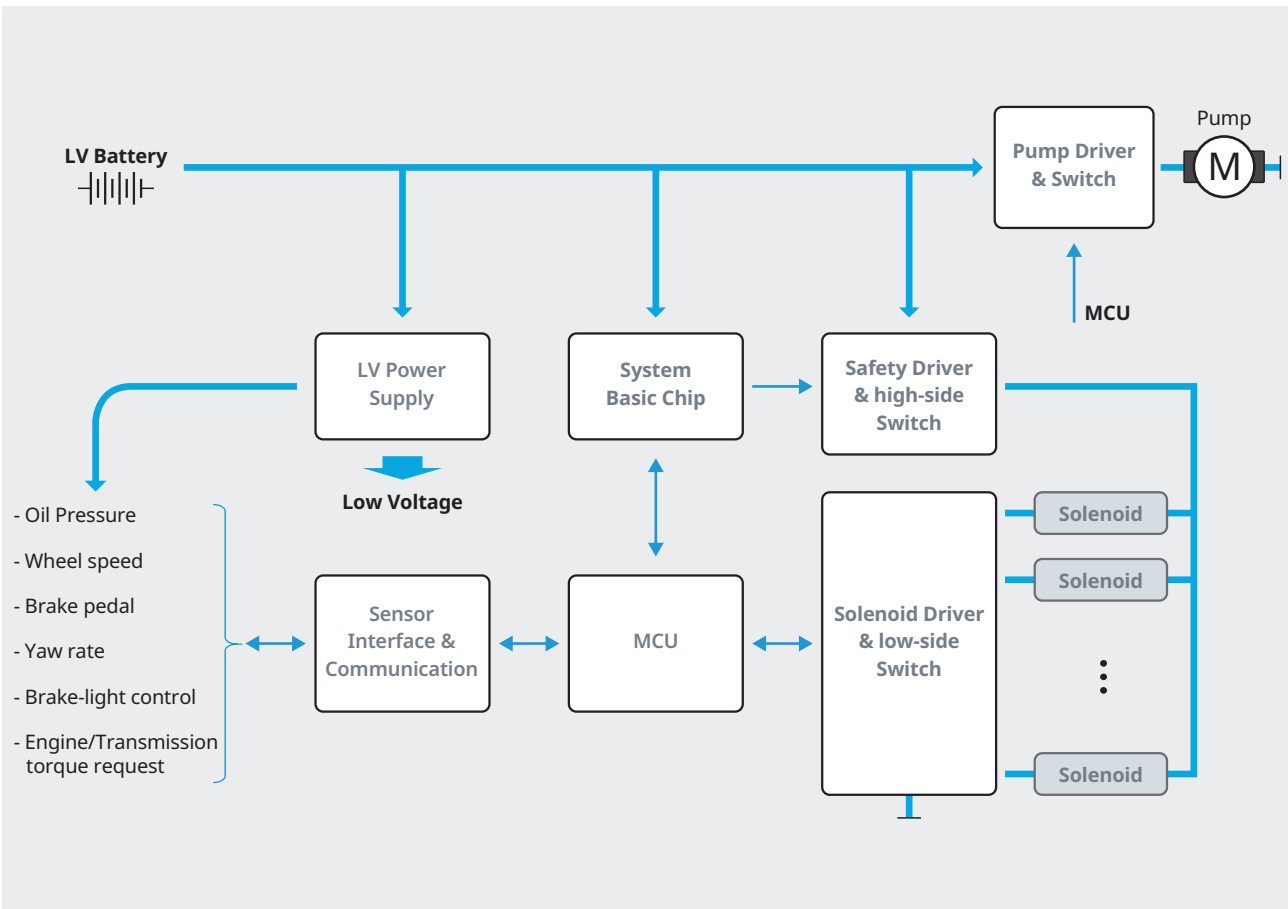

Samsung MLCCs for Automotive

Normal
(All Location)

X7* Normal(Epoxy)

PN Series 

COG Normal

PN Series 

Crack Mitigation
(12V Battery Line,
Near Hole & Connector)

Soft Termination

*PJ Series 

Fail Safe/Soft Term.

XPJ Series 

ESD Strengthen
(Connector I/F)

ESD Strengthen

PE Series 

High Temperature
(near Power Semiconductor)

X8* Normal

PN Series 

Electric Power Steering

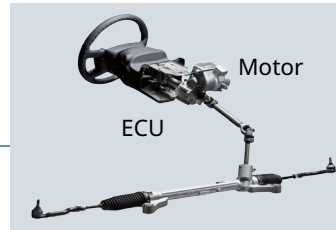

An Electric Power Steering (EPS) helps drivers turn a steering wheel of a vehicle via an electric motor. EPS gives an opportunity to augment the quality of driving to the driver, making it easier for the driver to put less efforts to turn the steering wheel.

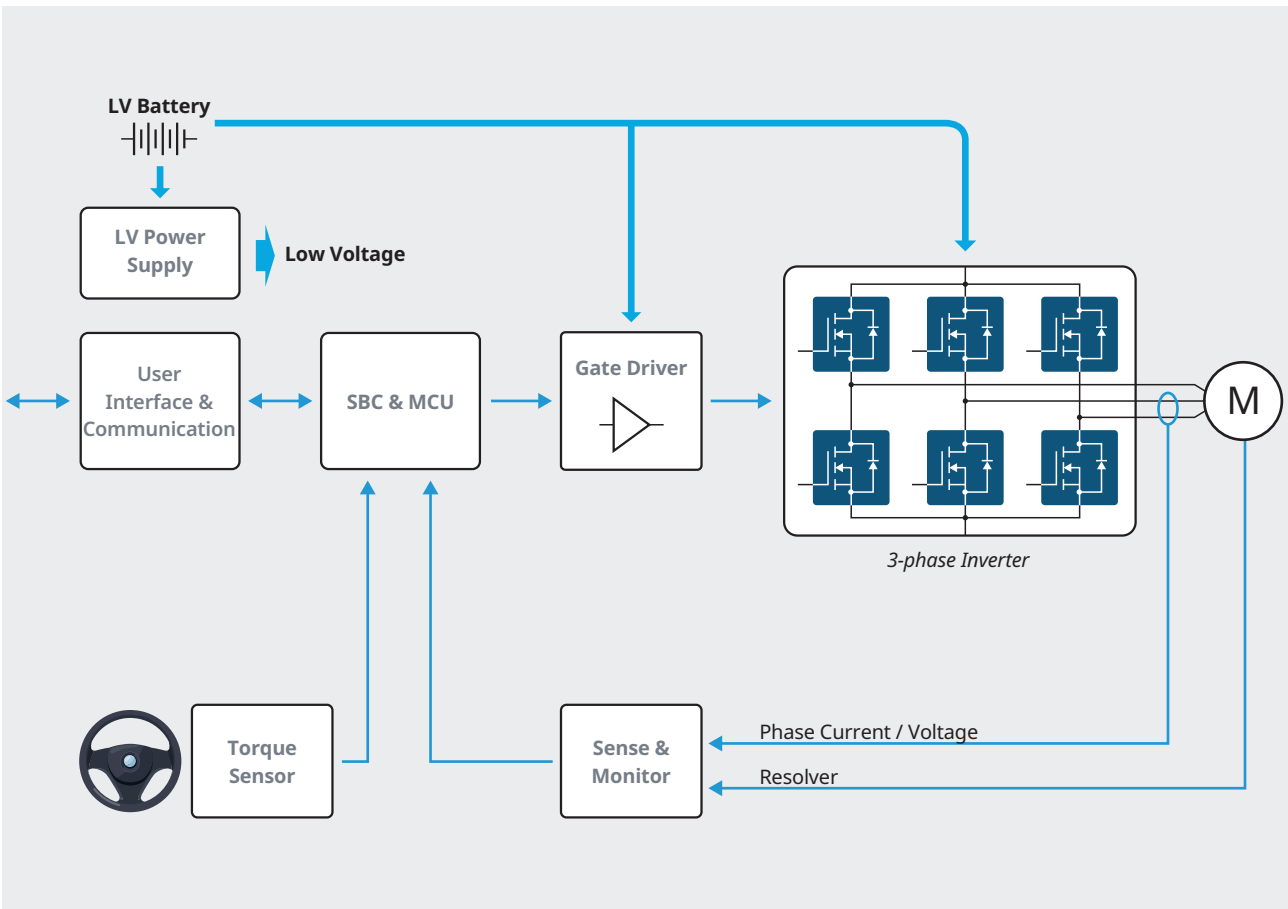

Normal
(All Location)

X7* Normal(Epoxy)

PN Series

COG Normal

PN Series

Crack Mitigation
(12V Battery Line,
Near Hole & Connector)

Soft Termination

*PJ Series

Fail Safe/Soft Term.

XPJ Series

ESD Strengthen
(Connector I/F)

ESD Strengthen

PE Series

LED Light Module with AFLS



A number of drivers favor a vehicle with head and rear ramps using LED that provides power efficiency, long lifespan and a various designs available. AFLS is an adaptive front lighting system to modulate the angles of the beam according to the driving direction of a vehicle.

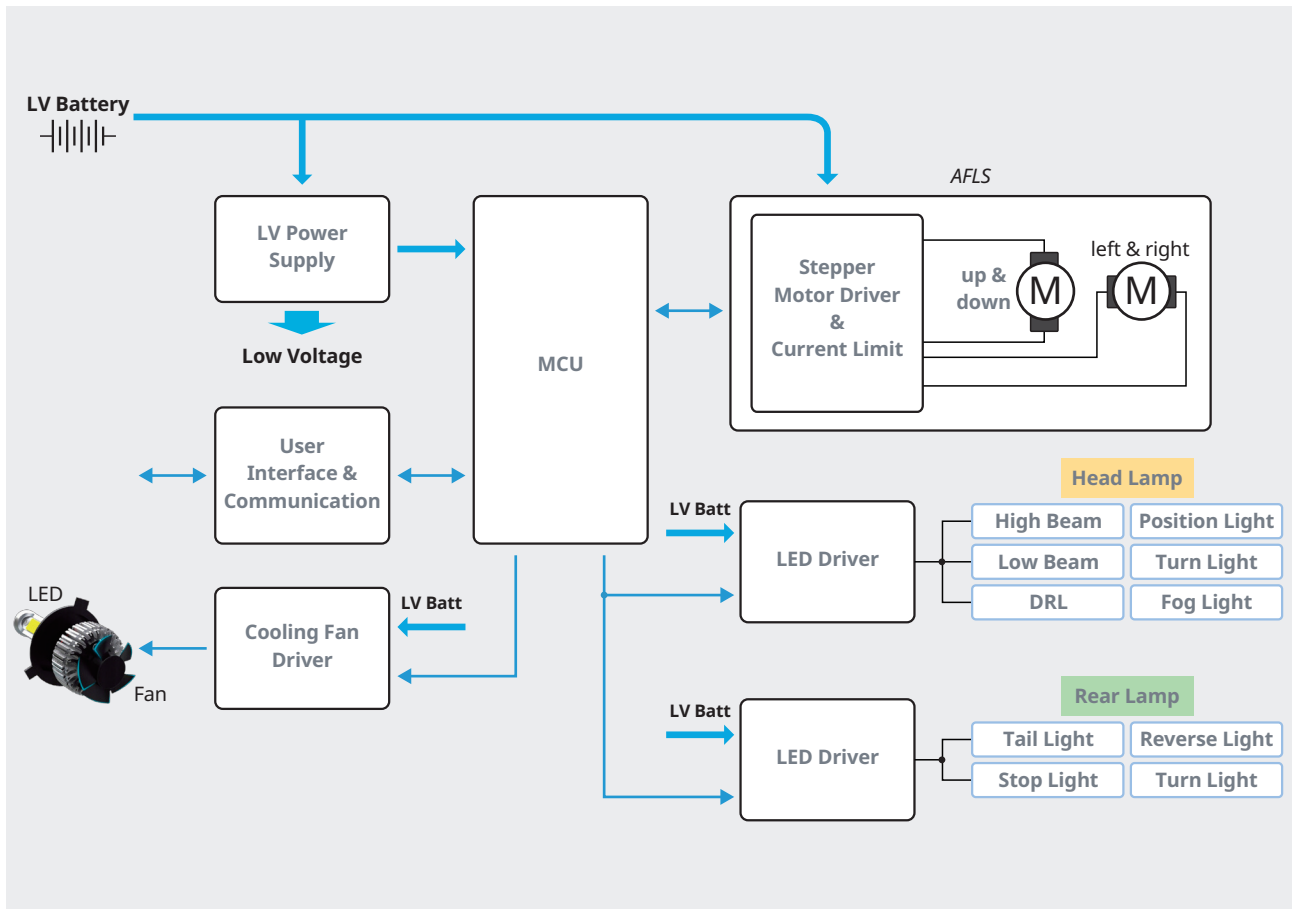

Normal
(All Location)

X7* Normal(Epoxy)

PN Series

COG Normal

PN Series

Crack Mitigation
(12V Battery Line,
Near Hole & Connector)

Soft Termination

*PJ Series

Fail Safe/Soft Term.

XPJ Series

ESD Strengthen
(Connector I/F)

ESD Strengthen

PE Series

High Temperature
(near Power Semiconductor)

X8* Normal

PN Series

Heating, Ventilation, Air Conditioning



A Heating & Ventilation, Air Conditioning (HVAC) system provides indoor environmental comfort of a vehicle: thermal comfort and high indoor air quality. For this, a heater, a fan and an air-conditioning compressor are operated after the HVAC system analyzes temperatures inside the vehicle. Actuators are used to control the direction of the fan and the air flow.

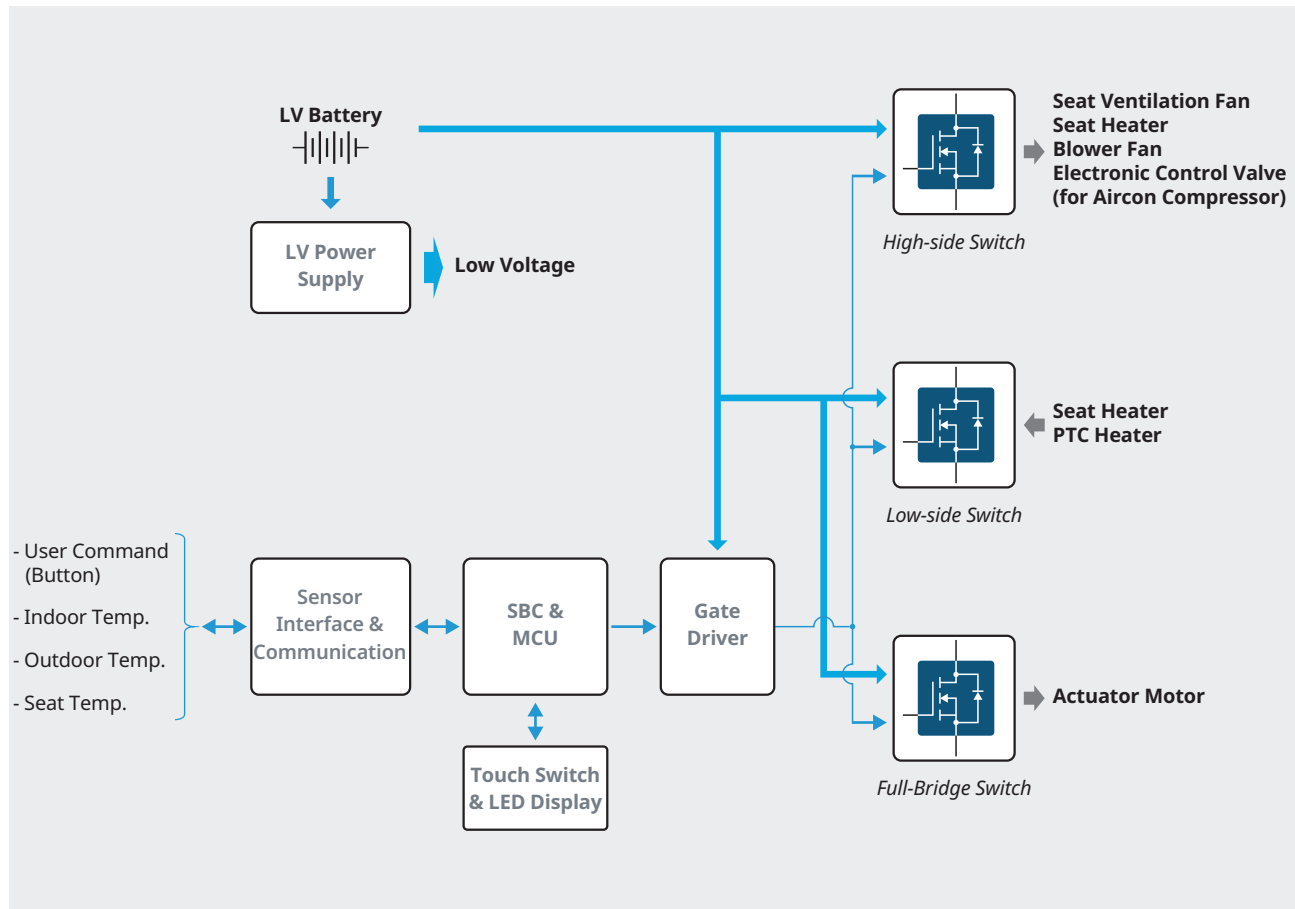

Samsung MLCCs for Automotive

Normal
(All Location)

X7* Normal(Epoxy)

PN Series

COG Normal

PN Series

Crack Mitigation
(12V Battery Line,
Near Hole & Connector)

Soft Termination

*PJ Series

Fail Safe/Soft Term.

XPJ Series

ESD Strengthen
(Connector I/F)

ESD Strengthen

PE Series

Smart key Control System & TPMS



A Smart Key Control System offers automatic driver recognition, a door lock and unlock function and an engine starter function. Basic functions and optional functions are available depending on a type of vehicles.

Samsung MLCCs for Automotive

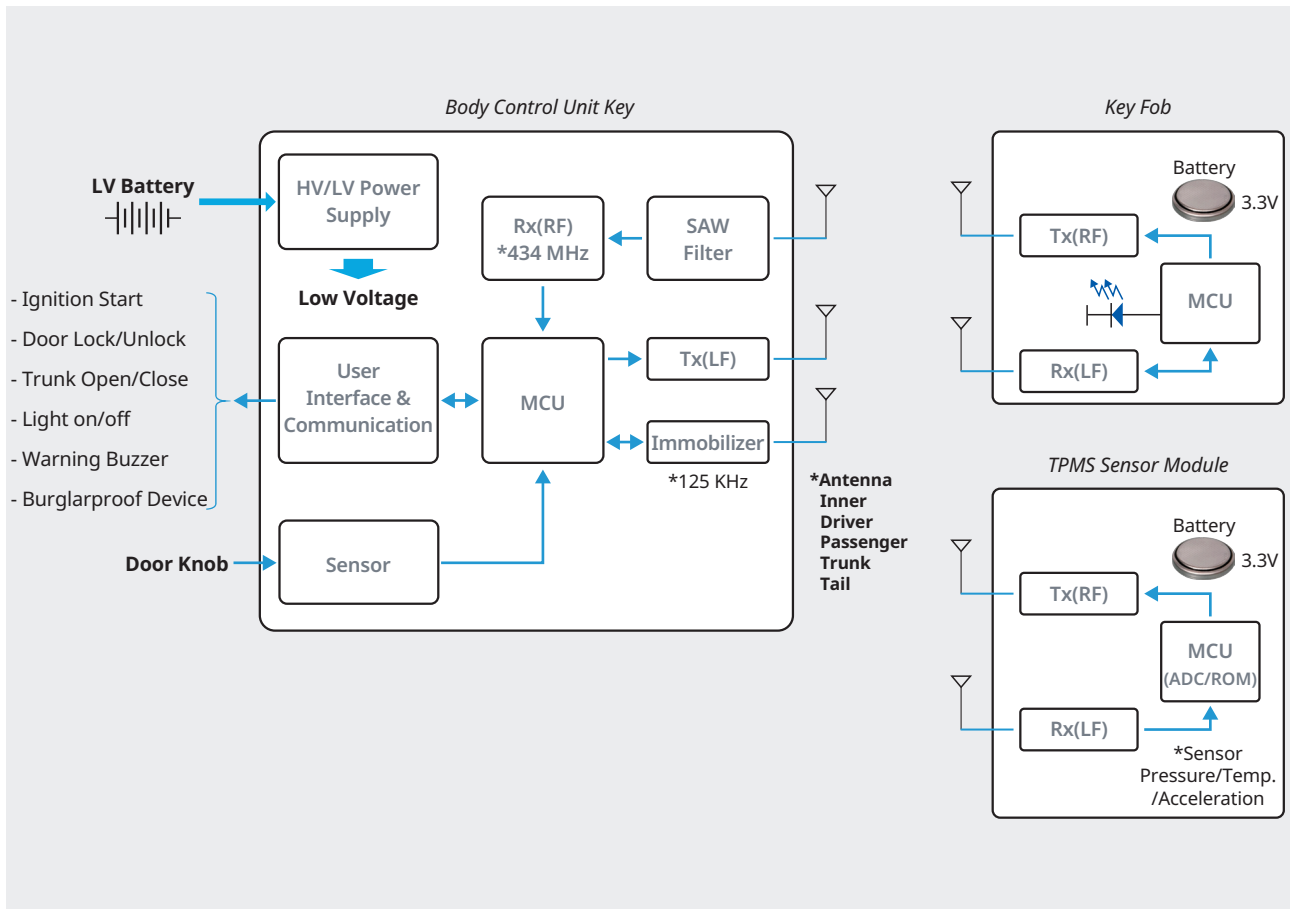

Normal
(All Location)

X7* Normal(Epoxy)

PN Series

COG Normal

PN Series

Crack Mitigation
(12V Battery Line,
Near Hole & Connector)

Soft Termination

*PJ Series

Fail Safe/Soft Term.

XPJ Series

ESD Strengthen
(Connector I/F)

ESD Strengthen

PE Series

Head Unit (for AVN)



A Head Unit is a main control system of AVN (Audio, Video, Navigation). It provides unified hardware interface for devices such as a camera, microphone and an antenna to turn on a video and a stereo system according to user command.

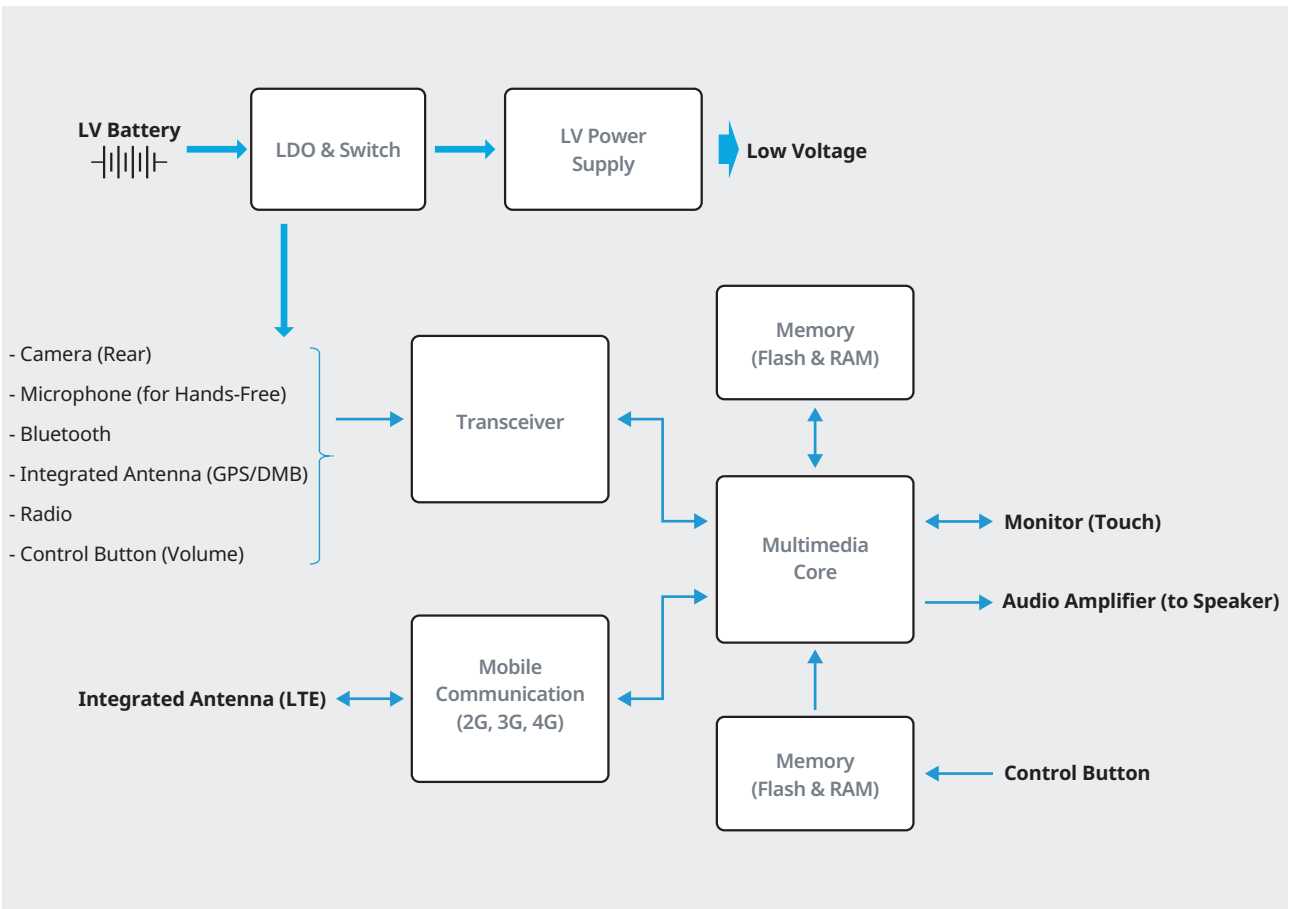

Normal (All Location)

X7* Normal(Epoxy)

PN Series

COG Normal

PN Series

Crack Mitigation (12V Battery Line, Near Hole & Connector)

Soft Termination

*PJ Series

Fail Safe/Soft Term.

XPJ Series

ESD Strengthen (Connector I/F)

ESD Strengthen

PE Series

Telematics Control Unit

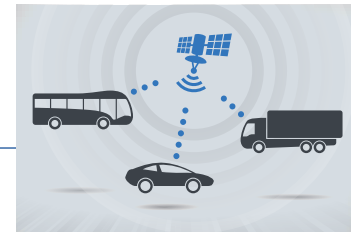

A Telematics Control Unit realizes a wireless network to provide an infotainment service such as route guidance using location information, traffic information, emergency recovery, the Internet, movies, games and so on, which is intended for drivers' safety and convenience.

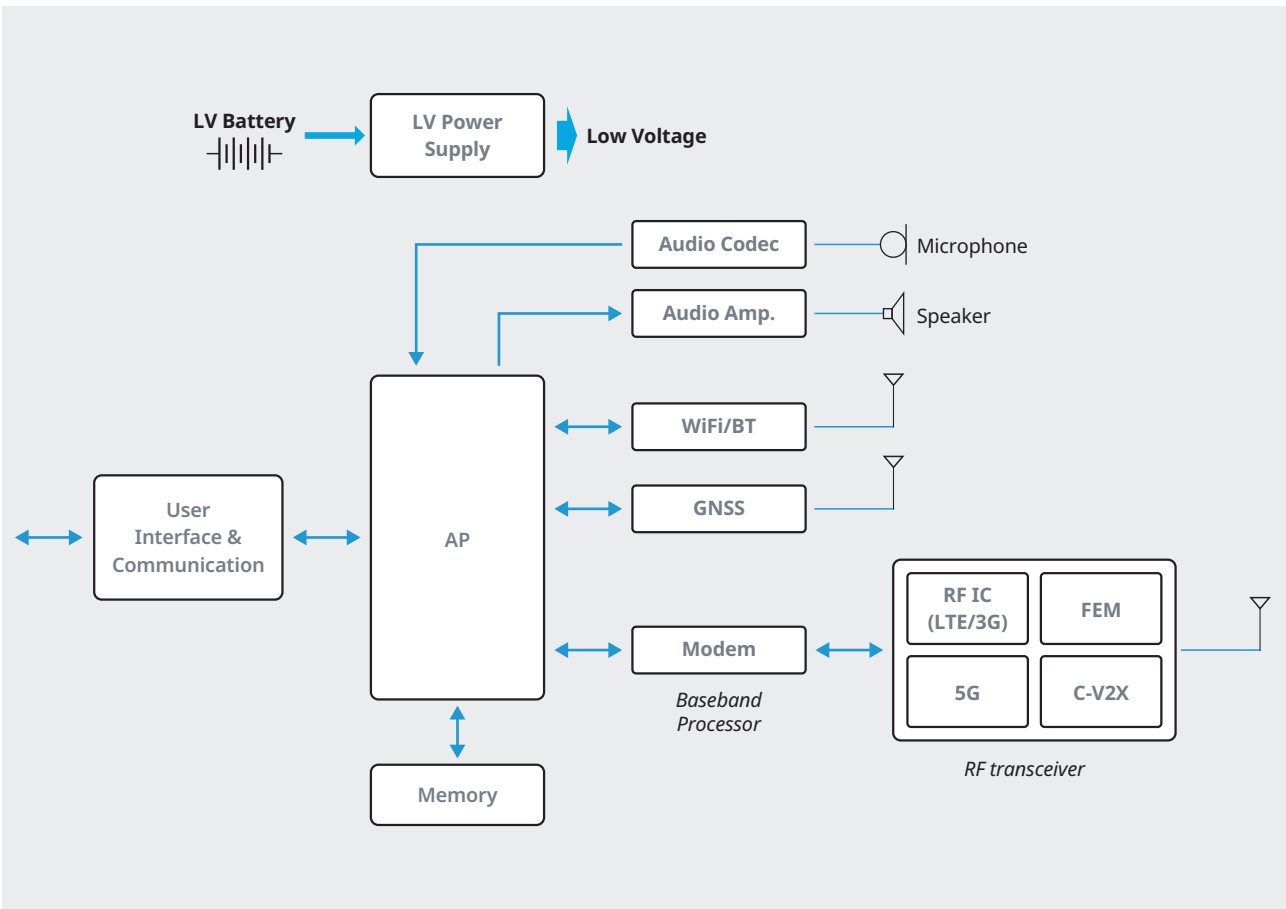

Normal
(All Location)

X7* Normal(Epoxy)

PN Series

COG Normal

PN Series

Crack Mitigation
(12V Battery Line,
Near Hole & Connector)

Soft Termination

*PJ Series

Fail Safe/Soft Term.

XPJ Series

ESD Strengthen
(Connector I/F)

ESD Strengthen

PE Series

Head Up Display



A Head Up Display (HUD) is a transparent display that presents data on driving with an image on a wind shield or a combiner from drivers viewpoint.

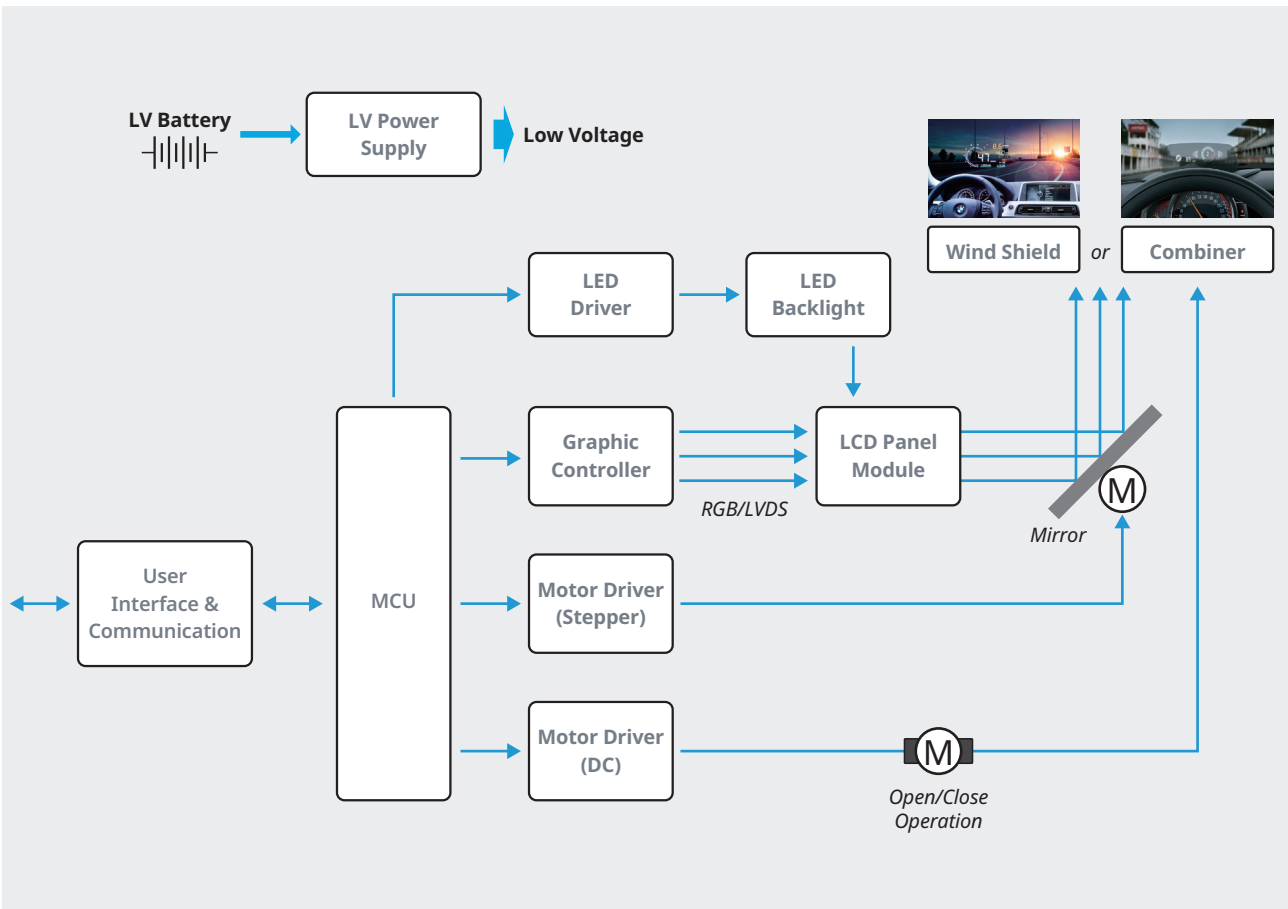

Normal
(All Location)

X7* Normal(Epoxy)

PN Series 

COG Normal

PN Series 

Crack Mitigation
(12V Battery Line,
Near Hole & Connector)

Soft Termination

*PJ Series 

Fail Safe/Soft Term.

XPJ Series 

ESD Strengthen
(Connector I/F)

ESD Strengthen

PE Series 

Smart Cruise Control (Radar)

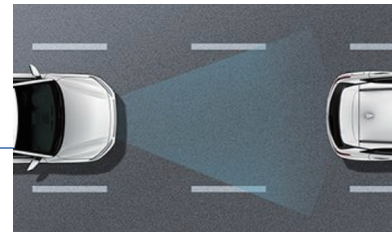

Smart Cruise Control (SCC) is a driver-friendly system to automatically adjust a vehicle speed and to maintain a safe distance from vehicles ahead by radar.

Samsung MLCCs for Automotive

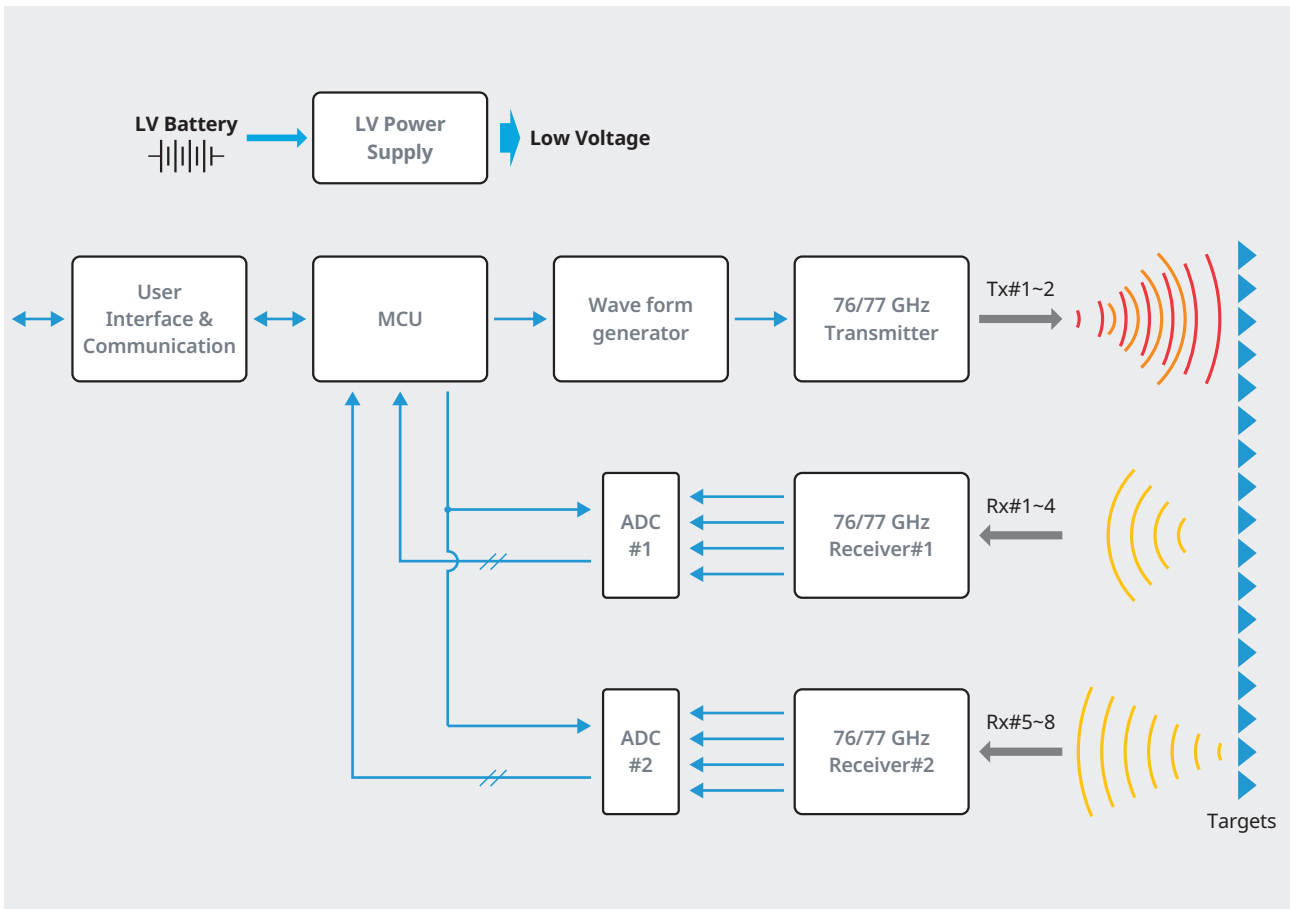

Normal
(All Location)

X7* Normal(Epoxy)

PN Series

COG Normal

PN Series

Crack Mitigation
(12V Battery Line,
Near Hole & Connector)

Soft Termination

*PJ Series

Fail Safe/Soft Term.

XPJ Series

ESD Strengthen
(Connector I/F)

ESD Strengthen

PE Series

Light Detection And Ranging

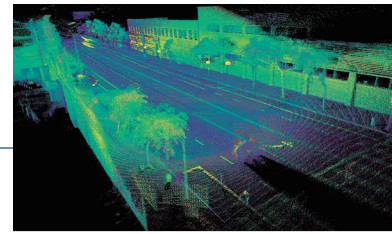

A LiDAR system creates 2D&3D images by measuring a distance with laser beam. LIDAR is considerable regarded as a significant technology to achieve complete autonomous driving.

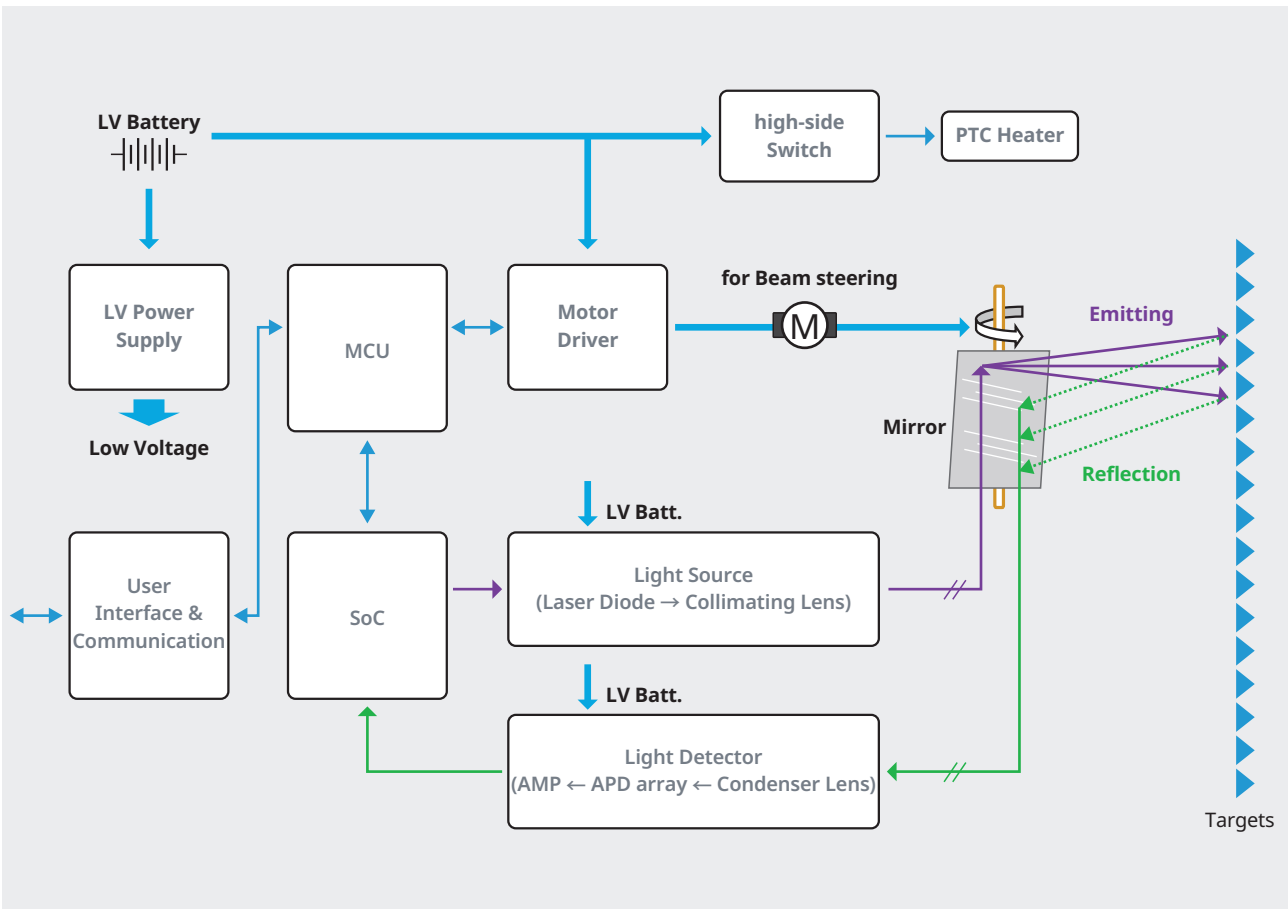

Samsung MLCCs for Automotive

Normal
(All Location)

X7* Normal(Epoxy)

PN Series

COG Normal

PN Series

Crack Mitigation
(12V Battery Line,
Near Hole & Connector)

Soft Termination

*PJ Series

Fail Safe/Soft Term.

XPJ Series

ESD Strengthen
(Connector I/F)

ESD Strengthen

PE Series

Night Vision System

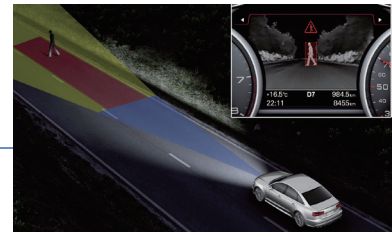

A Night Vision System is intended to take greater care of driver's view at night by providing reliable visual information. It enables drivers to increase their perception and seeing distance in darkness, which is beyond the reach of the vehicle's headlights. The Night Vision System uses an infrared camera using thermography or infrared reflective light for awareness of surroundings where human drivers hardly notice them in darkness.

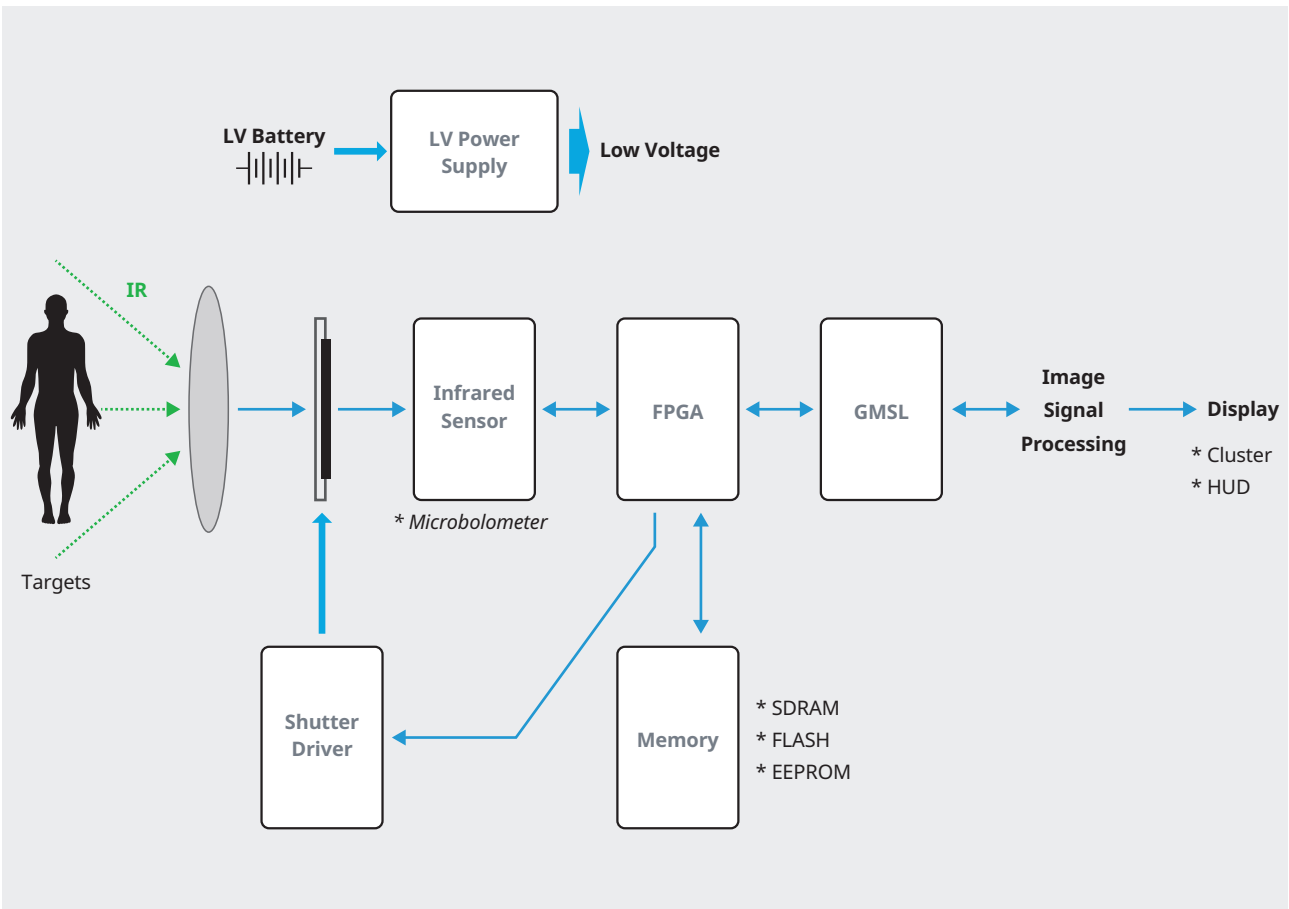

Samsung MLCCs for Automotive

Normal
(All Location)

X7* Normal(Epoxy)

PN Series

COG Normal

PN Series

Crack Mitigation
(12V Battery Line,
Near Hole & Connector)

Soft Termination

*PJ Series

Fail Safe/Soft Term.

XPJ Series

ESD Strengthen
(Connector I/F)

ESD Strengthen

PE Series

Autonomous Control Unit

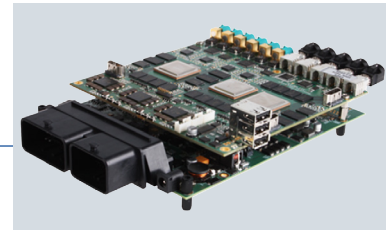

An autonomous vehicle is no longer to need driver's effort during driving safely, known as "Autonomous" or a "Driverless car", where the driver is able to leave all responsibility to operate systems. Autonomous unit analyzes big data on sensor, operating functions to search routes, control and drive the vehicle.

Samsung MLCCs for Automotive

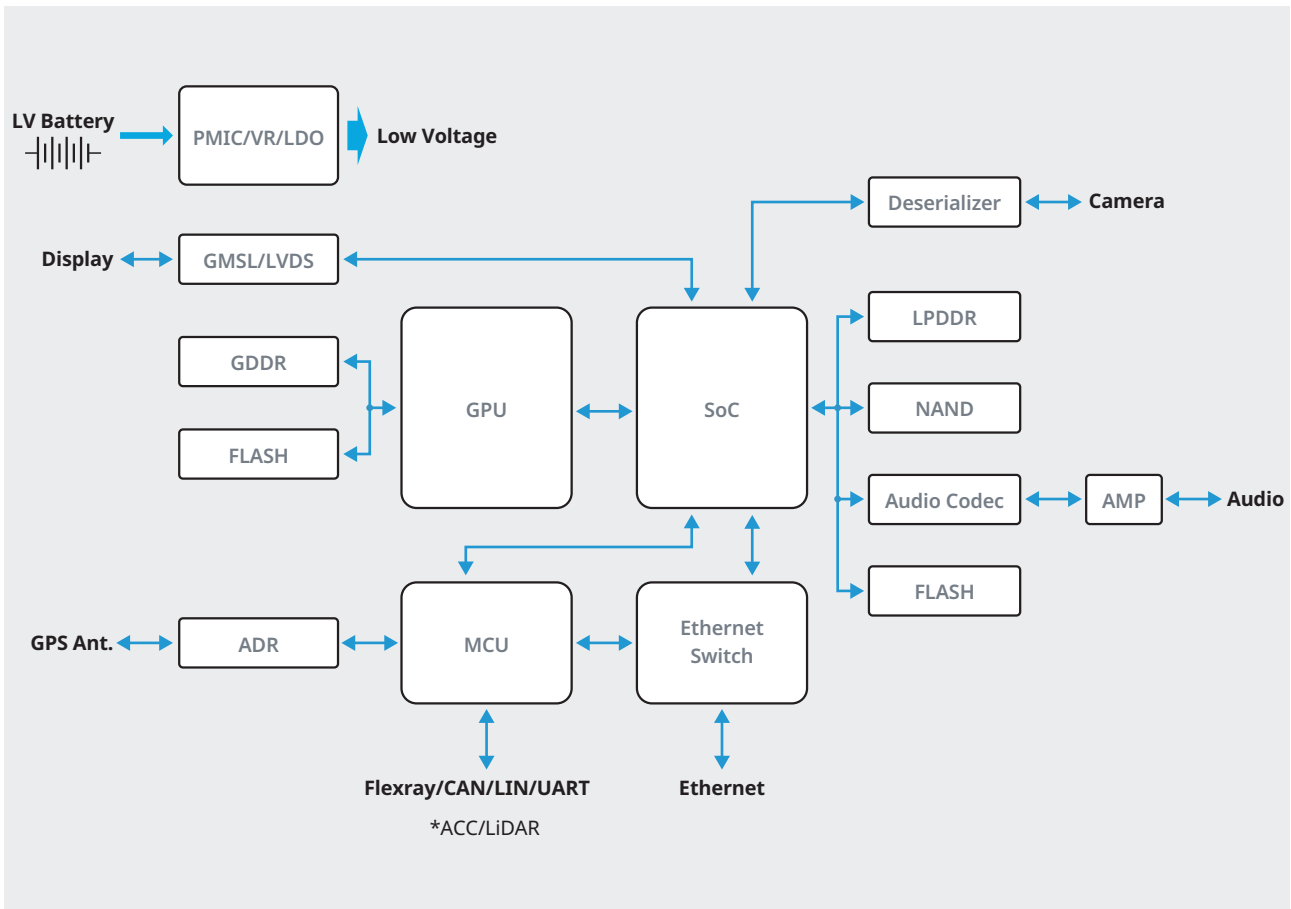

Normal
(All Location)

X7* Normal(Epoxy)

PN Series

COG Normal

PN Series

Crack Mitigation
(12V Battery Line,
Near Hole & Connector)

Soft Termination

*PJ Series

Fail Safe/Soft Term.

XPJ Series

ESD Strengthen
(Connector I/F)

ESD Strengthen

PE Series

Lineup Table

<http://product.samsungsem.com>

Automotive / Normal

Samsung MLCCs for Automotive

Category	TCC	Size Code (inch/mm)	Rated Vdc	Capacitance									Capacitance Range			
				pF				nF			uF					
				0.1	1	10	100	1	10	100	1	10		100		
AEC-Q200 Normal	C0G(125°C)	0402/1005	50												1pF - 220pF	
			100													2.2pF - 100pF
		0603/1608	50													1pF - 1nF
			100													5.6pF - 220pF
		0805/2012	50													
100															1nF - 1nF	
AEC-Q200 Normal (Epoxy)	X7R(125°C)	0402/1005	10												33nF - 220nF	
			16													1nF - 100nF
			25													1nF - 47nF
			50													330pF - 100nF
			100													1nF - 2.2nF
		0603/1608	6.3													1uF - 1uF
			10													220nF - 1uF
			16													68nF - 1uF
			25													1nF - 1uF
			50													220pF - 220nF
		0805/2012	100													220pF - 100nF
			6.3													4.7uF - 4.7uF
			10													1uF - 4.7uF
			16													150nF - 4.7uF
	25														150nF - 2.2uF	
	X7S(125°C)	0402/1005	35													1uF - 1uF
			50													100nF - 1uF
			100													22nF - 220nF
			10													4.7uF - 10uF
			16													2.2uF - 10uF
		1206/3216	25													2.2uF - 10uF
			50													330nF - 4.7uF
			100													470nF - 1uF
			10													22uF - 22uF
			16													22uF - 22uF
		1210/3225	25													4.7uF - 10uF
			50													1uF - 6.8uF
			100													2.2uF - 2.2uF
6.3															220nF - 1uF	
10														220nF - 1uF		
X7T(125°C)	0603/1608	16													220nF - 220nF	
		10													2.2uF - 2.2uF	
		6.3													10uF - 10uF	
	0805/2012	10													10uF - 10uF	
		16													10uF - 10uF	
		6.3													47uF - 47uF	
	1210/3225	10													47uF - 47uF	
		25													22uF - 22uF	
		50													6.8uF - 10uF	
		6.3													4.7uF - 4.7uF	

* The Lineup Table in this page is subject to change, modify or discontinue without notice.

Automotive / Crack Mitigation

Category	TCC	Size Code (inch/mm)	Rated Vdc	Capacitance									Capacitance Range			
				pF			nF			uF						
				0.1	1	10	100	1	10	100	1	10		100		
AEC-Q200 Soft Termination (5mm)	X7R(125°C)	0402/1005	16												10nF - 100nF	
			25												10nF - 22nF	
			50												10nF - 22nF	
		0603/1608	6.3													1uF - 1uF
			10													1uF - 1uF
			16													47nF - 1uF
			25													47nF - 1uF
		0805/2012	50													1nF - 220nF
			100													1nF - 47nF
			10													1uF - 1uF
			16													1uF - 4.7uF
		1206/3216	25													220nF - 1uF
	50														15nF - 1uF	
	100														10nF - 100nF	
	10														4.7uF - 4.7uF	
	1210/3225	16													4.7uF - 10uF	
25														4.7uF - 10uF		
50														1uF - 4.7uF		
X7S(125°C)	1206/3216	50													22uF - 22uF	
		50													10uF - 10uF	
		50													4.7uF - 4.7uF	
1210/3225	6.3														47uF - 47uF	
	50														10uF - 10uF	
AEC-Q200 Fail Safe/Soft Termination(5mm)	X7R(125°C)	0805/2012	50												100nF - 100nF	
			100													100nF - 100nF

Automotive / ESD Strengthen

Category	TCC	Size Code (inch/mm)	Rated Vdc	Capacitance									Capacitance Range		
				pF			nF			uF					
				0.1	1	10	100	1	10	100	1	10		100	
AEC-Q200 ESD Protection	X7R(125°C)	0603/1608	100												1nF - 6.8nF

Automotive / High Temperature

Category	TCC	Size Code (inch/mm)	Rated Vdc	Capacitance									Capacitance Range			
				pF			nF			uF						
				0.1	1	10	100	1	10	100	1	10		100		
AEC-Q200 Normal(Epoxy)	X8L(150°C)	0603/1608	25												220nF - 220nF	
		0805/2012	25													470nF - 470nF
		1206/3216	25													2.2uF - 2.2uF

* The Lineup Table in this page is subject to change, modify or discontinue without notice.



Passive components sales offices

Head office

Maeyoung-ro 150 (Maetan-dong) Yeongtong-gu, Suwon-city, Gyeonggi Province, Korea 16674
Tel : +82-31-210-5114

America Sales Office

San Jose Office

Samsung Electromechanics America Inc.
3655 North First Street
San Jose, CA, 95134
TEL : +1 408 544 4000
E-mail : soo8212.lee@samsung.com

Detroit Office

Samsung Electromechanics America Inc.
4121 N Atlantic Blvd.
Auburn Hills, MI, 48326
TEL : +1-713-395-5198
E-mail : eric.beaty@samsung.com

Europe Sales Office

Frankfurt office

Samsung Electro-Mechanics GmbH, Kolnerstr. 12
65760 Eschborn Germany
TEL : + 49-6196-66-7259
E-mail : benjamin.blume@samsung.com

Munich Office

Samsung Electro-Mechanics GmbH, Reichenbachstrasse 2
85737 Ismaning Germany
Tel : +49-6196-66-7237
E-mail : dimitri.hahn@samsung.com

Stuttgart Office

Samsung Electro-Mechanics GmbH, Leitzstrasse 45
70469 Stuttgart Germany
Tel : +49-711-490-66281
E-mail : laura.careno@samsung.com

Asia Sales Office

Shenzhen Office

14F, Tower A, SCC Building, Junction of Houhai Blvd. and Haide 1st Rd.
Nanshan District, Shenzhen, China, 518064
TEL : +86-755-8608-5984
E-mail : danny.huang@samsung.com

Shanghai Office

13F, Building B, No 1065 Zhongshan Rd.(W)
Changning District, Shanghai, China, 200051
TEL : +86-21-2051-5813
E-mail : cecilia.wang@samsung.com

Chongqing Office

Chongqing IFS Tower 1, Qingyun Road No. 1
Jiangbei District, Chongqing, China, 400023
TEL : +86-23-6711-9168(#6347)
E-mail : elvis.xu@samsung.com

Beijing Office

14F Room C1C2, China Merchants Tower, No.118 Jianguo Rd.
Chaoyang District, Beijing, China, 100022
TEL : +86-10-6566-8100(#6622)
E-mail : iris.wang@samsung.com

Taipei Office

9F-1, No.399 Rueykuang Rd.
Neihu District, Taipei, Taiwan, 11492
TEL : +886-2-2656-8375
E-mail : peter.tung@samsung.com

Tokyo Office

Shinagawa Grand Tower 9F, Kounan 2-16-4
Minato-ku, Tokyo, Japan, 108-0075
TEL : +81-3-6369-6452
E-mail : hikota.suga@samsung.com

Singapore Office

3 CHURCH STREET #23-01 SAMSUNG HUB
Singapore 049483
TEL : +65-6933-2636
E-mail : jessica.benegildo@samsung.com

Passive components manufacturing sites

Busan Plant (Korea)

Noksan Saneopjungro 333 (Songjeong-dong),
Gangseo-gu, Busan 46754
Tel : +82-51-970-7114, 8114

Tianjin Plant (China)

80, Xiaqing road, TEDA west district, Tianjin, China
TEL : +86-22-2830-3333(3500)

All information indicated in this catalog is as of May 2020

* The specifications and designs contained herein may be subject to change without notice.

* For more information about our distributor, please go to the website : SUPPORT → Sales Partners