

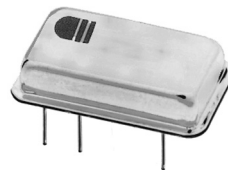
Table of Contents

| | |
|---|--------------|
| DS11 Series DC Relays, 2 Amp Output Rating, Qualified to DSCC Drawing 88062 | 10-2 – 10-5 |
| DS13 Series DC Relays, 2 Amp Output Rating, Qualified to DSCC Drawing 90091 | 10-6 – 10-9 |
| MS14 Series Solid State Relay | 10-10, 10-11 |
| JTS5, 6, & 7 Series, DC & Bi-Directional Output, Up to 250mA & 250V Output Rating, TO-5 Package, Qualified to MIL-PRF-28750/5, /6, & /7. | 10-12 |
| MS18 Series, DC & Bi-Directional Output, Up to 2A & 350V Output Rating, Qualified to DSCC Drawing 89116 | 10-13, 10-14 |
| JDS9 Series, AC Relays, 2A/250Vrms Rating, Qualified to MIL-PRF-28750/9. . . | 10-15, 10-16 |
| PS12 Series, AC Relays, 10A/250Vrms Rating, Qualified to DSCC Drawing 86031 | 10-17, 10-18 |
| PS10 Series, AC Relays, 25A/250Vrms Rating, Qualified to MIL-PRF-28750/10. | 10-19, 10-20 |
| JPS10 Series, AC Relays, 25A/250Vrms Rating, Qualified to MIL-PRF-28750/10. | 10-21, 10-22 |

DS11 Series SSR For DC Loads up to 2A @ 60Vdc

Product Facts

- Standard options: short circuit/overload protection, switch status and trip status
- Optically coupled all solid state relay
- TTL & CMOS compatible input
- Low on-resistance power MOSFET output
- Tested per MIL-PRF-28750D and approved to DSCC drawing 88062 with "Y" level screening



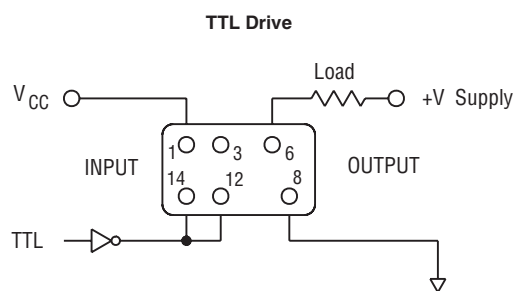
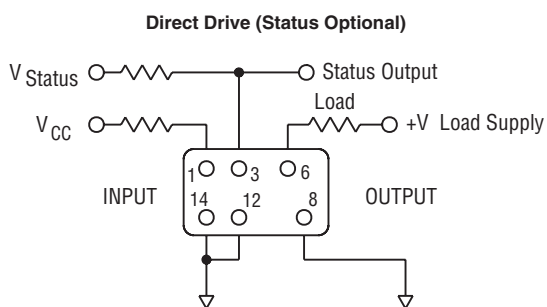
DS11 series SSRs feature state of the art photo-voltaic optical isolation and power MOSFET output chips for ultra-reliable high speed switching of DC loads up to 2 amps, with extremely low on-resistance. Standard options include integral current overload/short circuit protection to provide protection of the relay, load

and wiring; and isolated switch status or trip status. The overload feature provides protection if a short or overload develops while the relay is in the on state or if the relay is turned on into a dead short. Switch status, optically isolated from the load, signals the status of the output and provides a logic "0" when the output

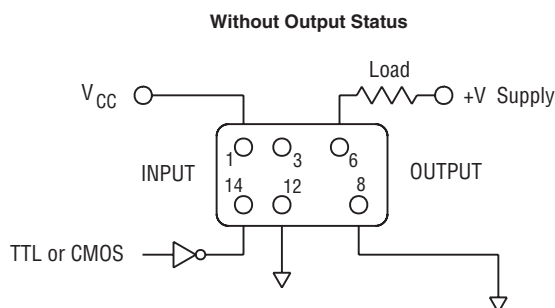
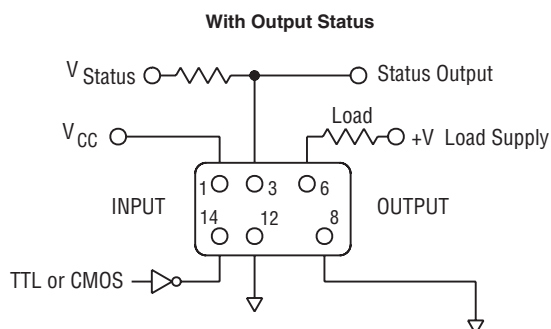
is off and a logic "1" when the output is on. Trip status, also optically isolated from the load, provides a logic "1" if the output trips off and a logic "0" when the output is in a normal condition, on or off, and is available only in conjunction with short circuit protection.

| KILOVAC Part No. | DSCC Dwg. No. | Relay Version |
|------------------|---------------|---|
| DS11-1Y | 88062-008 | Basic relay |
| DS11-1000 | 88062-004 | Relay w/ short circuit protection |
| DS11-1001 | 88062-006 | Relay w/ switch status |
| DS11-1002 | 88062-002 | Relay w/ short circuit protection and switch status |
| DS11-1003 | N/A | Relay w/ short circuit protection and trip status |

2 Terminal Input Configuration



3 Terminal Input Configuration



DS11 Series SSR For DC Loads up to 2A @ 60Vdc (Continued)

Environmental Characteristics

Ambient Temperature Range —

Operating — -55°C to +105°C
Storage — -55°C to +105°C

Vibration Resistance —

100 G's, 10-3,000 Hz

Shock Resistance —

50 G's, 11 ms pulse

Constant Acceleration Resistance

(Y1 axis) —

5,000 G's

Mechanical Characteristics

Weight (approx.) —

.176 oz. (5 grams)

Materials —

Header — KOVAR

Cover — Nickel

Pins — KOVAR, gold plated

Electrical Specifications (-55°C to +105°C unless otherwise specified)

Input (2 terminal configuration)

| | |
|----------------------------------|---|
| Input supply voltage range (Vcc) | 3.8 - 32 Vdc (Notes 1 & 2, Figures 1 & 2) |
| Input current (max.) @ 5Vdc | 15mAdc (Notes 1 & 2, Figures 1 & 2) |
| Must turn-on voltage | 3.8Vdc |
| Must turn-off voltage | 1.5Vdc |
| Reverse voltage protection | -32Vdc |

Input (3 terminal configuration)

| | |
|----------------------------------|---|
| Control voltage range | 0 - 18 Vd |
| Control current (max.) | 250µAdc @ 5V, 1mA @ 18V |
| Input supply voltage range (Vcc) | 3.8 - 32 Vdc (Notes 1 & 2, Figures 1 & 2) |
| Input current (max.) @ 5Vdc | 15mADC (Notes 1 & 2, Figures 1 & 2) |
| Must turn-on voltage | 0.3Vdc |
| Must turn-off voltage | 3.2Vdc |

I/O

| | |
|---------------------------------------|----------------------|
| Dielectric strength (min.) | 1,000V rms |
| Insulation resistance (min.) @ 500Vdc | 10 ⁹ ohms |
| Capacitance (max.) | 10pF |

Output

| | |
|--|-----------------------------|
| Continuous load current (max.) @ 25°C | 2.1Adc (Figure 7) |
| Continuous load voltage (max.) | 60Vdc |
| Transient blocking voltage (max.) | 80Vdc (Note 5) |
| On resistance (max.) @ T _j = 25°C, I _L = 100mA | 0.15 ohm (Note 6, Figure 6) |
| Output voltage drop (max.) | 0.5Vdc |
| Leakage current (max.) @ V = 60Vdc | 100µAdc |
| Leakage current (max.) @ V = 60Vdc, with switch status | 2mAdc |
| Turn-on time (max.) | 3 ms (Figure 3) |
| Turn-off time (max.) | 1 ms (Figure 3) |
| dv/dt (min.) | 100V / µs |
| Electrical system spike | 600Vdc (Note 5) |
| Output chip junction temperature (max.) | 125°C |
| Thermal resistance (max.), junction to ambient | 90°C/W |
| Thermal resistance (max.), junction to case | 25°C/W |

Status

| | |
|--|----------------------------|
| Status supply voltage range | 1 - 18Vdc |
| Status current (max.) @ V _{status} ≤ 0.4Vdc | 600µADC (Figure 5, Note 8) |
| Status leakage current (max.) @ 16Vdc | 10µAdc |
| Status turn-on time (max.) | 3.5 ms (Figure 4) |
| Status turn-off time (max.) | 8 ms (Figure 4) |

Short Circuit Protection

| | |
|---|---------|
| Current surge without tripping (max.), 100ms pulse | 4.25Adc |
| Overload trip current (max.), 0.5 ms pulse, V = 60Vdc | 10Adc |
| Trip time (typical), turning on into short | 400µs |
| Trip time (typical), shorting while relay is on | 280µs |

10

KILOVAC Solid State Relays

DS11 Series SSR For DC Loads up to 2A @ 60Vdc (Continued)

Figure 1 - Maximum Input Current vs. Input Voltage

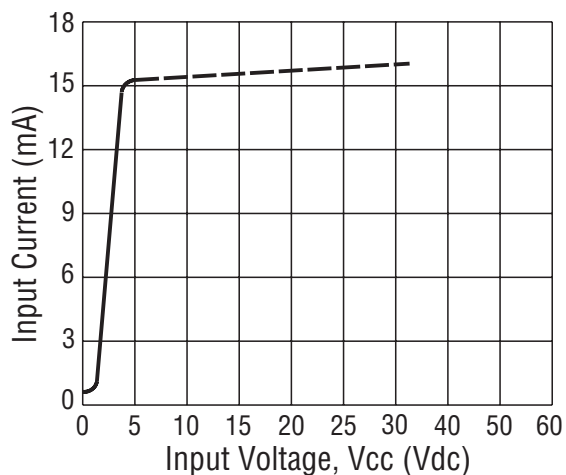


Figure 2 - Series Resistance vs. Vcc Supply Voltage (Note 1)

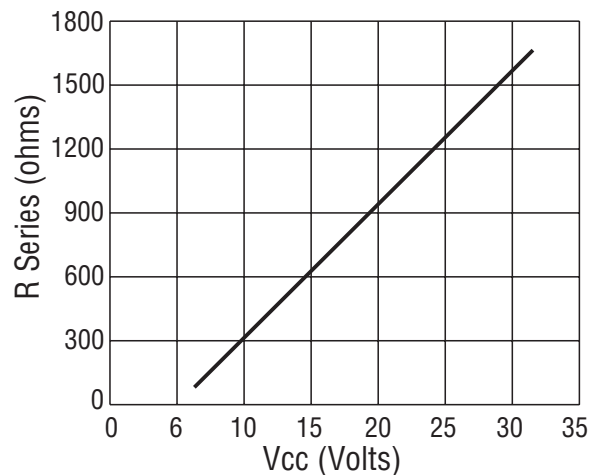


Figure 3 - Turn-on and Turn-off Timing

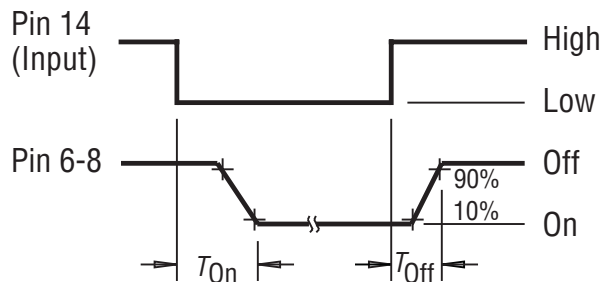


Figure 4 - Output Status Timing

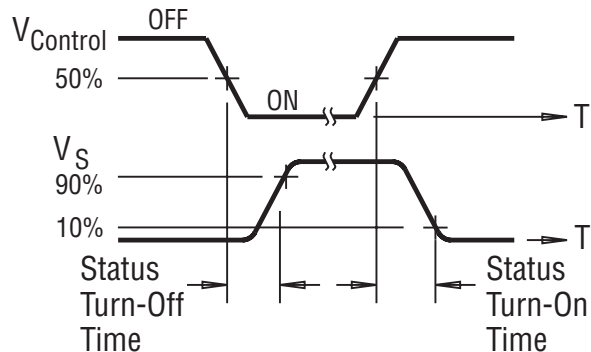


Figure 5 - Status Resistor vs. Status Supply Voltage

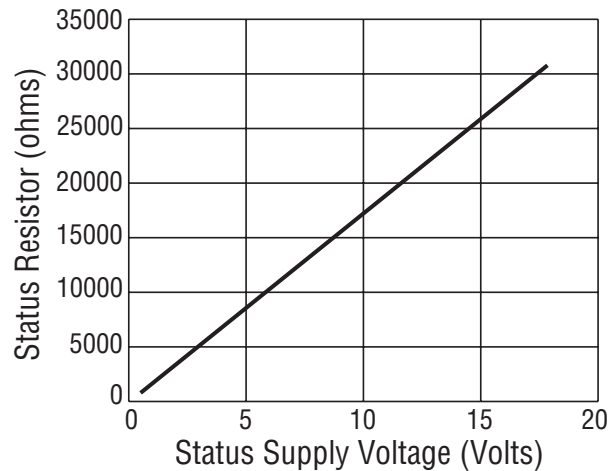
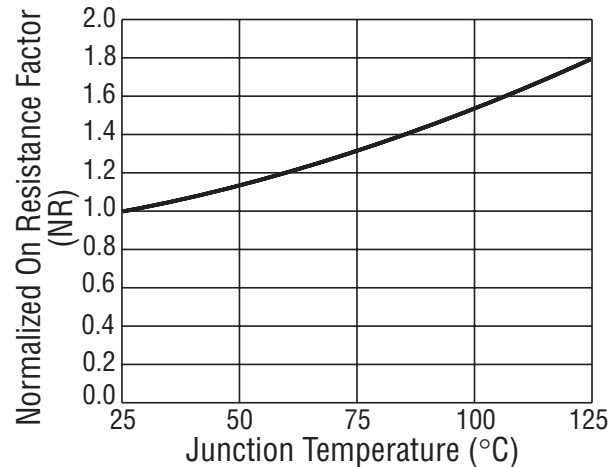


Figure 6 - On-Resistance vs. Temperature (Note 6)



DS11 Series SSR For DC Loads up to 2A @ 60Vdc (Continued)

Figure 7 - Temperature Derating Curve

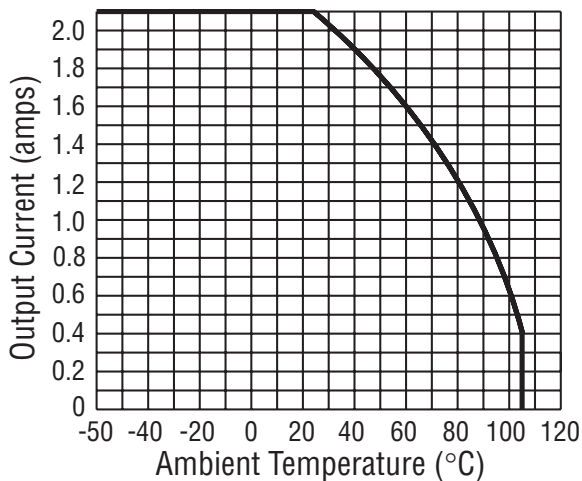


Figure 8 - Maximum Surge Current Without Tripping

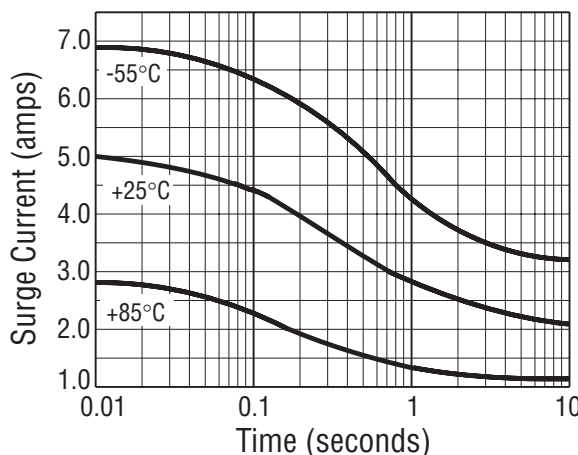
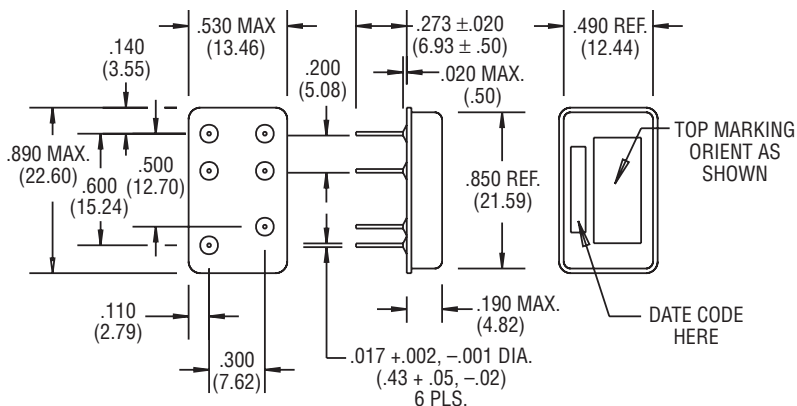


Figure 9 - Outline Dimensions



TOLERANCE:
 ± 0.010 (0.25mm) FOR 2 PLACE DECIMALS,
 ± 0.005 (0.13mm) FOR 3 PLACE DECIMALS.
 UNLESS OTHERWISE SPECIFIED

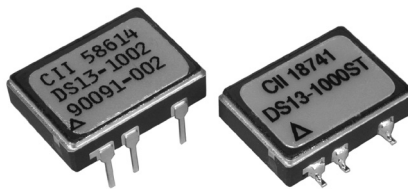
Notes

1. 2 terminal input configuration is compatible with CMOS or open collector TTL (with pull-up resistor). For Vcc levels above 6Vdc, a series limiting resistor is required. See Fig. 2 for resistor value. Use standard resistor value equal to or less than value from the curve.
2. Input transitions to be ≤ 1ms duration, and input direct drive should be "bounceless contact" type.
3. Vcc = 5Vdc for all tests unless otherwise specified.
4. All DS11 Series relays may drive loads connected to either positive or negative referenced power supply lines. Reversing polarity of output may cause permanent damage. Inductive loads must be diode suppressed.
5. Transient blocking voltage and electrical system spike tests are performed per MIL-STD-704 (28VDC systems).
6. To determine the maximum on-resistance at any given junction temperature, multiply on-resistance at 25°C (0.15 ohm) by normalized on-resistance factor from curve (Fig. 6).
7. Overload testing per MIL-R-28750 is constrained to the limits imposed by the short circuit protection requirements of this specification and DSCC drawing 88062. Load circuit series inductance for "load shorted" mode of operation to be limited to 50mH max. Maximum repetition rate into a shorted load should not exceed 10 Hz.
8. Proper operation of the status feedback requires a status pull-up resistor. See Fig. 5 for status resistor value.

DS13 SSR for loads up to 2A @ 60Vdc

Product Facts

- Standard options: short circuit/overload protection and control status.
- Optically coupled all solid state relay.
- TTL & CMOS compatible input.
- Low on-resistance power MOSFET output.
- Tested per MIL-PRF-28750D and approved to DSCC drawing 90091.
- All versions available with Tyco Electronics "W" level screening for KILOVAC relays.



DS13 series SSRs employ state of the art photovoltaic optical isolation and power MOSFET output chips for ultra-reliable high speed switching of DC loads up to 2 amps, with low on-resistance. Standard options include integral current overload/short

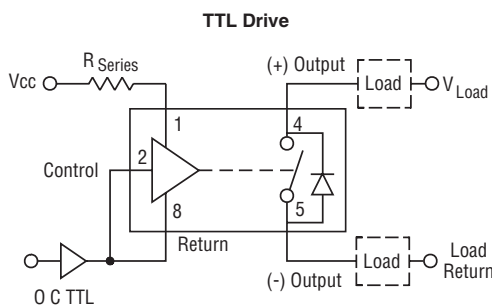
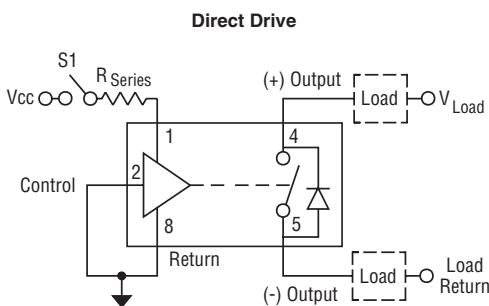
circuit protection and a separate input control status line. The overload feature provides protection of the relay, load and load circuit wiring in the event of a sustained current overload or short circuit while the relay is on or when it is turned on into a short. The

control status provides a built-in test function which provides a logic "0" when the input circuit is energized and functional. The relay is packaged into a custom hermetically sealed low-profile 8-pin ceramic DIP package, with through hole or surface mount pins.

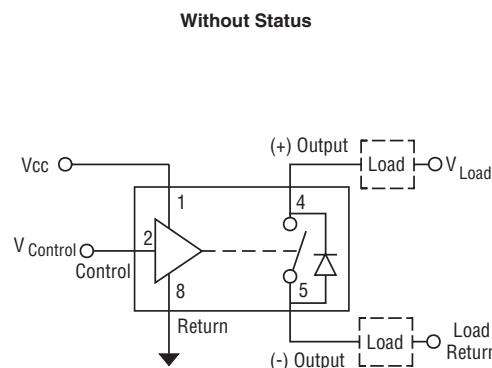
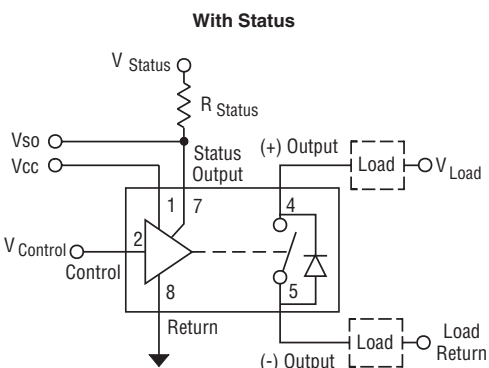
| KILOVAC Part No. | DSCC Dwg. No. | Relay Version |
|------------------|---------------|--|
| DS13-1Y | 90091-008 | Basic relay |
| DS13-1000 | 90091-004 | Relay w/ short circuit protection |
| DS13-1001 | 90091-006 | Relay w/ control status |
| DS13-1002 | 90091-002 | Relay w/ short circuit protection and control status |

Notes: Add suffix "S" to part number for surface mount versions.
 Add suffix "T" to part number for tinned leads.
 Add suffix "W" to part number for lower screening level.

2 Terminal Input Configuration



3 Terminal Input Configuration



DS13 SSR for loads up to 2A @ 60Vdc (Continued)

Environmental Characteristics

Ambient Temperature Range:

Operating: -55°C to +105°C.
Storage: -55°C to +125°C.

Vibration Resistance:

100 G's, 10-3,000 Hz.

Shock Resistance:

1,500 G's, 0.5 ms pulse.

Constant Acceleration Resistance:

5,000 G's.

Mechanical Characteristics

Weight (max.):

.07 oz. (2 grams)

Materials:

Case: DIP, hermetically sealed, ceramic

Pins: Copper, gold plated

Electrical Specifications (-55°C to +105°C unless otherwise specified)

Input (2 terminal configuration)

| | |
|----------------------------------|---|
| Input supply voltage range (Vcc) | 3.8 - 32 Vdc (Notes 1 & 2, Figures 1 & 2) |
| Input current (max.) @ 5Vdc | 15mA _{dc} (Notes 1 & 2, Figures 1 & 2) |
| Must turn-on voltage | 3.8Vdc |
| Must turn-off voltage | 1.5Vdc |
| Reverse voltage protection | -32Vdc |

Input (3 terminal configuration)

| | |
|----------------------------------|---|
| Control voltage range | 0 - 18 Vdc |
| Control current (max.) | 240 μ A _{dc} @ 5V, 1mA @ 18V |
| Input supply voltage range (Vcc) | 3.8 - 32 Vdc (Notes 1 & 2, Figures 1 & 2) |
| Input current (max.) @ 5Vdc | 15mA _{dc} (Notes 1 & 2, Figures 1 & 2) |
| Must turn-on voltage | 0.3Vdc |
| Must turn-off voltage | 3.2Vdc |

I/O

| | |
|---------------------------------------|----------------------|
| Dielectric Strength (min.) | 1,000V rms |
| Insulation Resistance (min.) @ 500Vdc | 10 ⁹ ohms |
| Capacitance (max.) | 10pF |

Output

| | |
|--|---------------------------------------|
| Continuous load current (max.) @ 25°C, without short circuit protection | 2.0A _{dc} (Figure 5, Note 3) |
| Continuous load current (max.) @ 25°C, with short circuit protection | 1.0A _{dc} (Figure 5, Note 3) |
| Continuous load voltage (max.) | 60Vdc |
| Transient blocking voltage (max.) | 80Vdc (Note 4) |
| On resistance (max.) @ T _j = 25°C, I _L = 100ma, with short circuit protection | 0.45 ohm (Note 5, Figure 4) |
| On resistance (max.) @ T _j = 25°C, I _L = 100ma, without short circuit protection | 0.22 ohm (Note 5, Figure 4) |
| Output voltage drop (max.), with short circuit protection | 0.6Vdc |
| Output voltage drop (max.), without short circuit protection | 0.75Vdc |
| Off-state leakage current (max.) @ 60Vdc | 100 μ A _{dc} |
| Turn-on time (max.) | 1.5 ms (Figure 3) |
| Turn-off time (max.) | .25 ms (Figure 3) |
| dv/dt (min.) | 100V / μ s |
| Electrical system spike | \pm 600Vdc (Note 4) |
| Junction temperature (max.) | 150°C |
| Thermal resistance (max.), junction to ambient | 80°C/W |
| Thermal resistance (max.), junction to case | 20°C/W |

Status

| | |
|--|----------------------------|
| Status supply voltage | 30Vdc |
| Status sink current (max.) @ V _{status} \leq 0.3Vdc | 2mA _{dc} (Note 7) |
| Status leakage current (max.) @ 15Vdc | 4 μ A _{dc} |

Short Circuit Protection

See Figure 6, Note 7

DS13 SSR for loads up to 2A @ 60Vdc (Continued)

Figure 1 - Maximum Input Current vs. Input Voltage

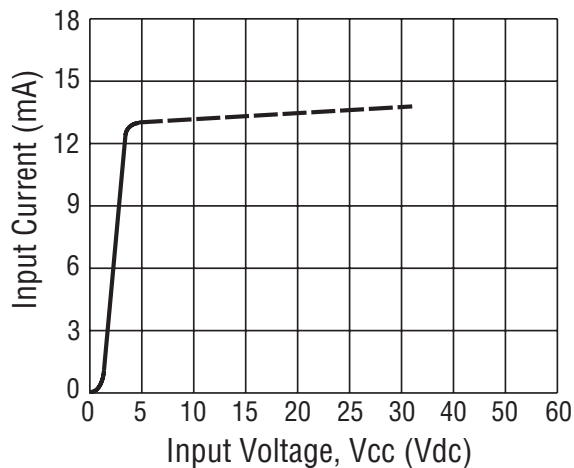


Figure 2 - Series Resistance vs. Vcc Supply Voltage (Note 1)

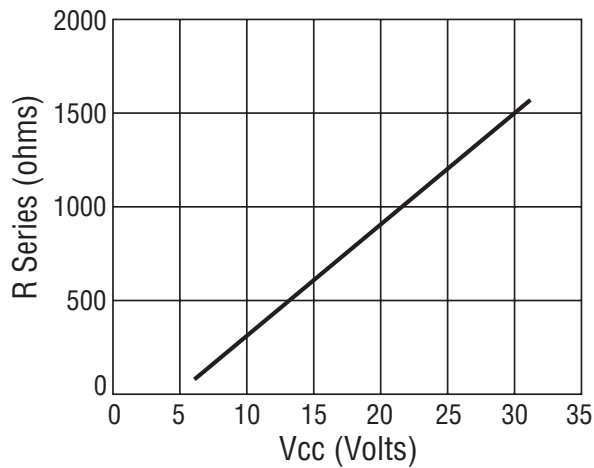


Figure 3 - Output Turn-on and Turn-off Timing

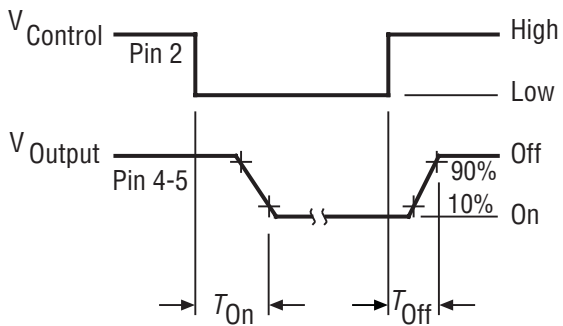


Figure 4 - On-Resistance vs. Temperature (Note 6)

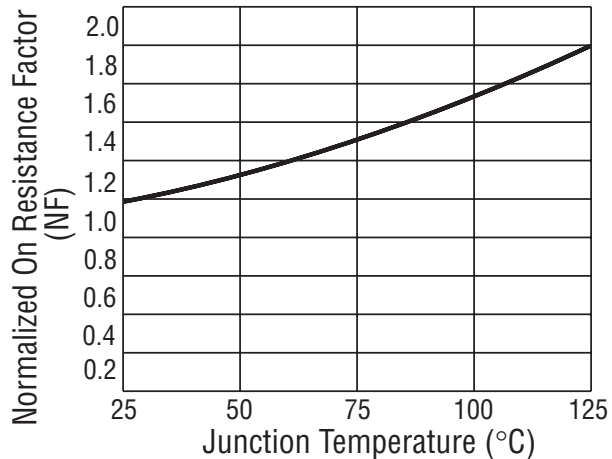


Figure 5 - Temperature Derating Curve

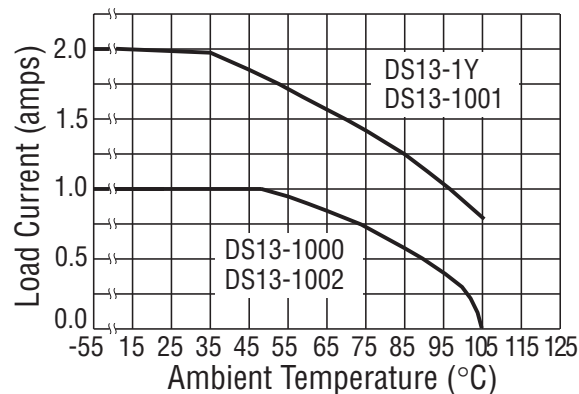
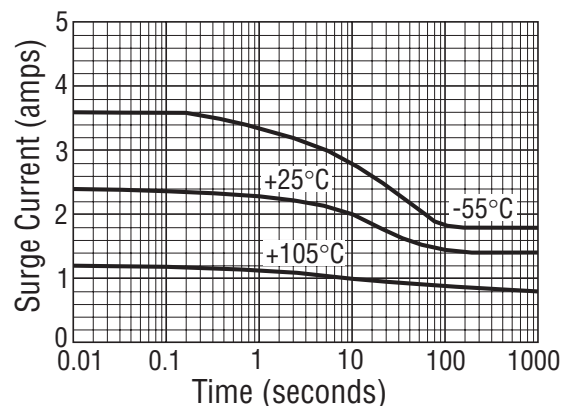
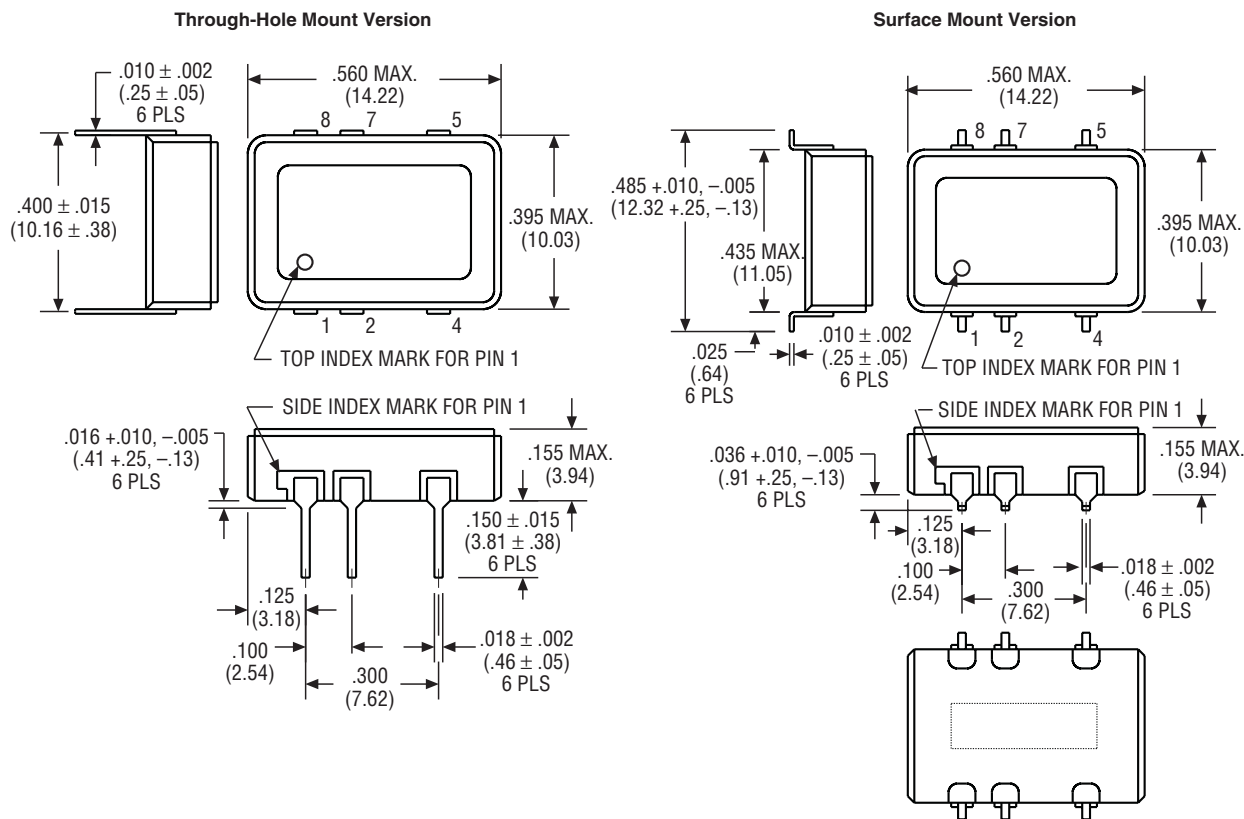


Figure 6 - Typical Current Trip Levels



DS13 SSR for loads up to 2A @ 60Vdc (Continued)

Figure 7 - Outline Dimensions



10
KILOVAC Solid State Relays

Notes

1. 2 terminal input configuration is compatible with CMOS or open collector TTL (with pull-up resistor). For Vcc levels above 6Vdc, a series limiting resistor is required. See Fig. 2 for resistor value. Use standard resistor value equal to or less than value from the curve.
2. Vcc = 5Vdc for all tests unless otherwise specified.
3. All DS13 Series relays may drive loads connected to either positive or negative referenced power supply lines. Reversing polarity of output may cause permanent damage. Inductive loads must be diode suppressed.
4. Transient blocking voltage & electrical system spike tests are performed per MIL-STD-704 (28Vdc systems).
5. To determine the maximum on-resistance at any given junction temperature, multiply on-resistance at 25°C by normalized on-resistance factor from curve (Fig. 4).
6. Overload testing per MIL-R-28750 is constrained to the limits imposed by the short circuit protection requirements of this specification and DSCC drawing 90091. Load circuit series inductance for "load shorted" mode of operation to be limited to 50mH max. Maximum repetition rate into a shorted load should not exceed 10 Hz. To calculate maximum on-resistance at any temperature, use the following equation: $R(on) = R(on) @ 25^{\circ}C \times NF$ (without short circuit protection) and $R(on) = 0.2 \times NF + .21$ (with short circuit protection) where NF = normalized on-resistance factor from Fig. 4.
7. Proper operation of the status feedback requires a status pull-up resistor. Select the status resistor such that it limits status output current to 2mA: $R_{status} = \frac{V_{status}}{I_{status}} - 0.3V / 2mA$.

MS14 Series Solid State Relay, With DC or Bi-Directional Output to 350mA @ 400V

Product Facts

- 1000V optical isolation protects control and driver circuitry from load transients.
- Buffered/current limited input for direct drive from CMOS or TTL logic.
- Power MOSFET output chips for low voltage drop.
- 90 & 240mA output current.
- 85, 100 & 400V output voltage.
- Subminiature hermetically sealed .100 grid package.
- Screened per "Y" level of MIL-PRF-28750D.
- Direct replacement for TELEDYNE M92F & M93F series

Environmental Characteristics

Ambient Temperature Range:

Operating: -55°C to +105°C.
Storage: -55°C to +125°C.

Vibration Resistance:

30 G's, 10-3,000 Hz.

Shock Resistance:

1,500 G's, 0.5 ms pulse.

Constant Acceleration Resistance:

5,000 G's.

Mechanical Characteristics

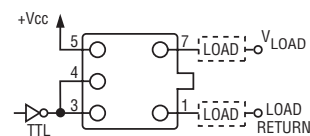
Weight (max.):

.07 oz. (2 grams)

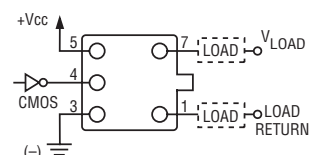
Materials:

Case: Nickel, hermetically sealed.
Pins: Kovar, gold plated

TTL Configuration



CMOS Configuration



© 2011 by Tyco Electronics Corporation. All Rights Reserved.

TE logo and Tyco Electronics are trademarks.

Other products and company names mentioned herein may be trademarks of their respective owners.



MS14 series subminiature SSRs employ state of the art photo-voltaic optical isolation providing 1000Vrms input/output isolation and power mosfet output chips for ultra-reliable

high speed switching of DC or bidirectional loads up to 350mA and 400Vdc. The input is current regulated and buffered to minimize power dissipation and permit driving the relay direct

from CMOS or TTL. The relay is packaged in a custom hermetically sealed low-profile .100 grid package which conserves space for high density PC board circuitry.

Ordering Information

| KILOVAC Part No. | DSCC Drawing/Pin No. | Output Rating |
|------------------|----------------------|---------------|
| MS14-1Y | 87034-001 | 350mA / 400V |
| MS14-2Y | 87034-002 | 135mA / 400V |
| MS14-3Y | 87034-003 | ±240mA / 85V |

Electrical Specifications (-55°C to +105°C unless otherwise specified)

Input (TTL Drive)

| | |
|----------------------------------|---|
| Input supply voltage range (Vcc) | 3.8 - 32 Vdc (Notes 1 & 2, Figures 1 & 2) |
| Input current (max.) @ 5Vdc | 16mAdc (Notes 1 & 2, Figures 1 & 2) |
| Must turn-on voltage | 3.8Vdc |
| Must turn-off voltage | 1.5Vdc |

Input (CMOS Drive)

| | |
|----------------------------------|---|
| Control voltage range | 0 - 18 Vdc |
| Control current (max.) | 250µAdc @ 5V, 1mA @ 18V |
| Input supply voltage range (Vcc) | 3.8 - 32 Vdc (Notes 1 & 2, Figures 1 & 2) |
| Input current (max.) @ 5Vdc | 16mAdc (Notes 1 & 2, Figures 1 & 2) |
| Must turn-on voltage | 0.3Vdc |
| Must turn-off voltage | 2.8Vdc |

I/O

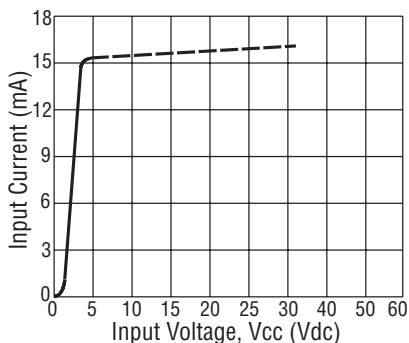
| | |
|---------------------------------------|----------------------|
| Dielectric Strength (min.) | 1,000V rms |
| Insulation Resistance (min.) @ 500Vdc | 10 ⁹ ohms |

Output

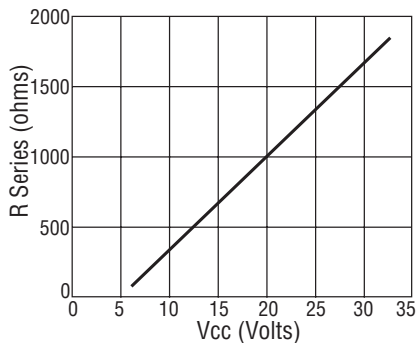
| | |
|---|-----------|
| Continuous load current (max.) @ 25°C: MS14-1Y | 350mAdc |
| Continuous load current (max.) @ 25°C: MS14-2Y | 135mAdc |
| Continuous load current (max.) @ 25°C: MS14-3Y | +/- 240mA |
| Continuous load voltage (max.) @ 25°C: MS14-1Y | 100Vdc |
| Continuous load voltage (max.) @ 25°C: MS14-2Y | 400Vdc |
| Continuous load voltage (max.) @ 25°C: MS14-3Y | +/- 85V |
| On resistance (max.) @ T _j = 25°C, I _L = 100mA: MS14-1Y | 4 ohms |
| On resistance (max.) @ T _j = 25°C, I _L = 100mA: MS14-2Y | 25 ohms |
| On resistance (max.) @ T _j = 25°C, I _L = 100mA: MS14-3Y | 8 ohms |
| Off-state leakage I (max.) @ 80% max. V @ -55 to +25°C | 1µA |
| Off-state leakage I (max.) @ 80% max. V @ =25 to +85°C | 50µA |
| Junction temperature (max.) | 150°C |
| Turn-on time (max.) MS14-1Y & -2Y | .7mS |
| Turn-on time (max.) MS14-3Y | 2mS |
| Turn-off time (max.) (all versions) | 1mS |

**MS14 Series Solid State Relay,
With DC or Bi-Directional Output to 350mA @ 400V** (Continued)

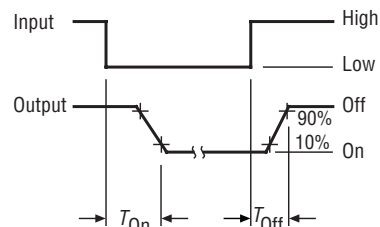
**Figure 1 -
Max. Input Current vs. Input Voltage**



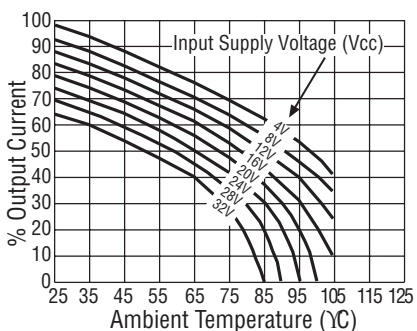
**Figure 2 -
Series Res. vs. Vcc Supply Voltage (Note 1)**



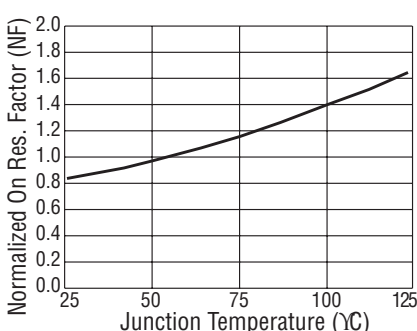
**Figure 3 -
Output Turn-on and Turn-off Timing**



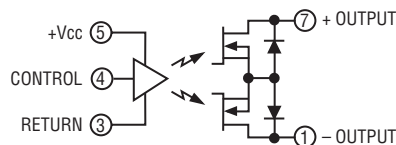
**Figure 4 -
Temperature Derating Curve**



**Figure 5 -
On-Resistance vs. Temperature (Note 6)**

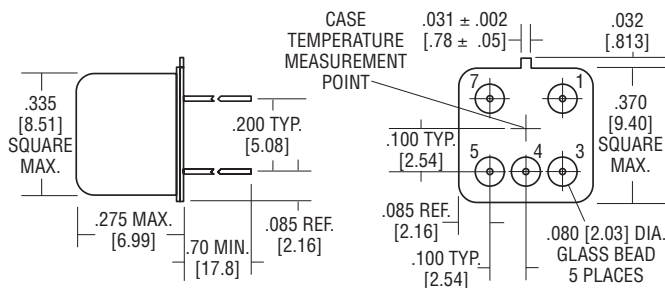


**Figure 6 -
Simplified Circuit**



Note: MS14-1Y and -2Y have a single output chip.

Figure 7 - Outline Dimensions



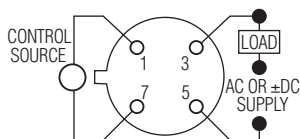
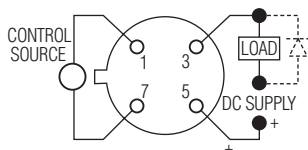
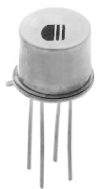
Unless otherwise specified, tolerances are:
±0.010 [0.25] for 2 place decimals
±0.005 [0.13] for 3 place decimals

Terminal numbers are for reference only and do not appear on the header.

Notes

1. 2 terminal input configuration is compatible with CMOS or open collector TTL (with pull-up resistor).
2. For Vcc levels above 6Vdc, a series limiting resistor is required. See Fig. 2 for resistor value. Use standard resistor value equal to or less than value from the curve.
3. Vcc = 5Vdc for all tests unless otherwise specified.
4. All MS14 Series relays may drive loads connected to either positive or negative referenced power supply lines. Inductive loads must be diode suppressed.
5. If an input series current limiting resistor is used, derating of output current vs. Vcc is not necessary. Curve for 4V applies.
6. On-resistance at any ambient temperature other than 25°C can be computed as follows:
 $R (@ \text{any } T) = R (@ +25^\circ\text{C}) \times e^{e^{0.006} T}$, where T = new temperature - 25°C, e = 2.7182818.

JTS5, 6, & 7 Series, DC & Bi-Directional Output, Up to 250mA & 250V Output Rating, TO-5 Package

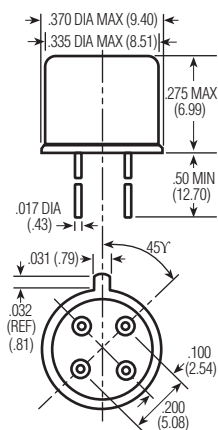


Terminal View

Input Characteristics
Input Voltage Range — 4.0 – 7.0 Vdc
Maximum Turn-on Voltage — 5.0 Vdc
Minimum Turn-off Voltage — 1.0 Vdc
I/O Dielectric — 1000 Vac pk-pk

Output Characteristics
Max. Output Current (Continuous, 25°C) — 50 mAac or mAac (JTS5-1Y)
 250 mAac (JTS6-1Y)
 100 mAac (JTS7-1Y)
Max. Output Voltage — 40 Vac or Vdc (JTS5-1Y)
 40 Vdc (JTS6-1Y)
 250 Vdc (JTS7-1Y)
Max. On-resistance — 5 ohms (JTS5-1Y)
Turn-on Time — 10 µsec.
Turn-off Time — 15 µsec.

Environmental Characteristics
Shock — 1500 G's, 0.5 ms.
Vibration — 100 G's, 10 to 2000 Hz
Operating Ambient Temperature — -55 to +125°C

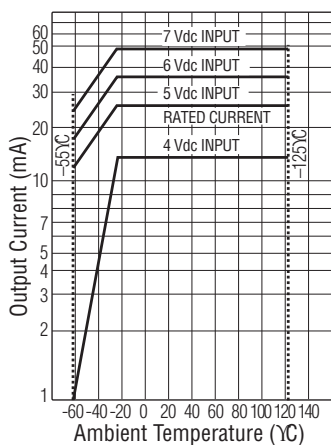


JTS5/JTS6/JTS7

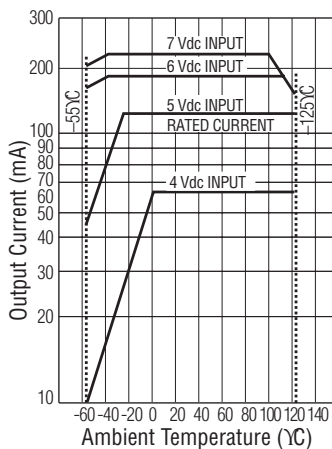
Product Facts

- Hermetically sealed TO-5 package
- Transformer coupled
- High speed switching
- JTS5-1Y switches AC or DC
- Qualified to M28750/5, 6, & 7

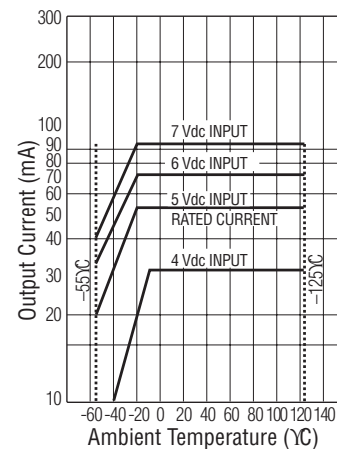
- Notes:** 1) Reversing polarity of input (or output except for JTS5-1) may cause permanent damage.
 2) Input must be a step function. Rise or fall time, as applicable, not to exceed 100 µsec.
 3) Inductive loads must be diode suppressed.
 4) For any control voltage, the maximum load current shown on graphs must not be exceeded. Attempting to draw currents in excess of those specified on graphs can cause permanent damage.



JTS5-1Y



JTS6-1Y



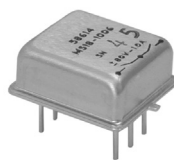
JTS7-1Y

Output Current Vs. Input Control Voltage and Ambient Temperature

MS18-1006 High Performance DC and Bi-directional Solid State Relay For Loads up to 2A @ 80Vdc

Product Facts

- Bi-directional power FET output
- Optically coupled
- Low on-resistance
- Extremely low leakage current
- Subminiature hermetically sealed package
- Tested per MIL-PRF-28750D and approved to DSCC drawing 89116-006



The MS18-1006 is an optically coupled SSR employing power MOSFET output chips in an inverse series configuration for switching DC or bi-directional loads. A common source connection is provided for the

user to configure the output switching circuit for DC operation up to 2A with very low on-resistance. The relay features fast switching speeds, low off-state leakage, virtually zero offset voltage and the capability to with-

stand high inrush currents up to 350% of rated. The low profile subminiature package is hermetically sealed with pinouts on a 0.1" x 0.3" grid pattern.

Environmental Characteristics

Ambient Temperature Range —
 Operating — -55°C to +120°C
 Storage — -55°C to +125°C

Vibration Resistance —
 100 G's, 10-2,000 Hz

Shock Resistance —
 1,500 G's, 0.5 ms pulse

Constant Acceleration Resistance (Y-1 axis) —
 5,000 G's

Mechanical Characteristics

Weight (approx.) —
 .07 oz. (5 grams)

Materials —
 Header — Kovar® Alloy
 Cover — Grade A Nickel
 Pins — Kovar® Alloy, gold plated

KOVAR is a trademark of Carpenter Technology Corporation.

| KILOVAC Part No. | DSCC Dwg. No. | Relay Version |
|------------------|---------------|---------------|
| MS18-1006 | 89116-006 | Basic relay |

Electrical Specifications (-55°C to +120°C unless otherwise specified)

| Input | |
|---|----------------------|
| Input current (max.) | 25mA _{dc} |
| Input voltage drop (max. @ 25mA) | 1.5 V _{dc} |
| Must turn-on current | 10mA |
| Must turn-off current | 10µA |
| Reverse voltage protection | -5.0V _{dc} |
| I/O | |
| Dielectric strength (60Hz., 1mA leakage) | 500V rms |
| Insulation resistance (min.) @ 500V _{dc} | 10 ⁹ ohms |
| Capacitance (max. @ 25V _{dc} , 1 Mhz) | 5pF |
| Output | |
| Continuous load current, parallel (DC) configuration (max.) | 2A (Figure 2) |
| Continuous load current, series (bi-directional) configuration (max.) | 1A (Figure 2) |
| Continuous operating load voltage (max.) | +/- 80V |
| Transient blocking voltage (5 sec max.) | +/- 90V |
| Overload (100ms, 10% duty cycle, 10 cycles max.) | 350% of rated |
| dv/dt (min.) | 100V / µs |
| On resistance (max.), parallel (DC) configuration | 0.4 ohm |
| On resistance (max.), series (bi-directional) configuration | 0.6 ohm |
| Turn-on time (max, @ +/- 80V) | 800µs (Figure 3) |
| Turn-off time (max, @ +/- 80V) | 500µs (Figure 3) |
| Thermal resistance, junction to ambient | 110°C/W |
| Thermal resistance, junction to case | 20°C/W |

Figure 1 – Wiring Diagrams



10
KILOVAC Solid State Relays

MS18-1006 High Performance DC and Bi-directional Solid State Relay For Loads up to 2A @ 80Vdc (Continued)

Figure 2 - Temperature Derating Curves

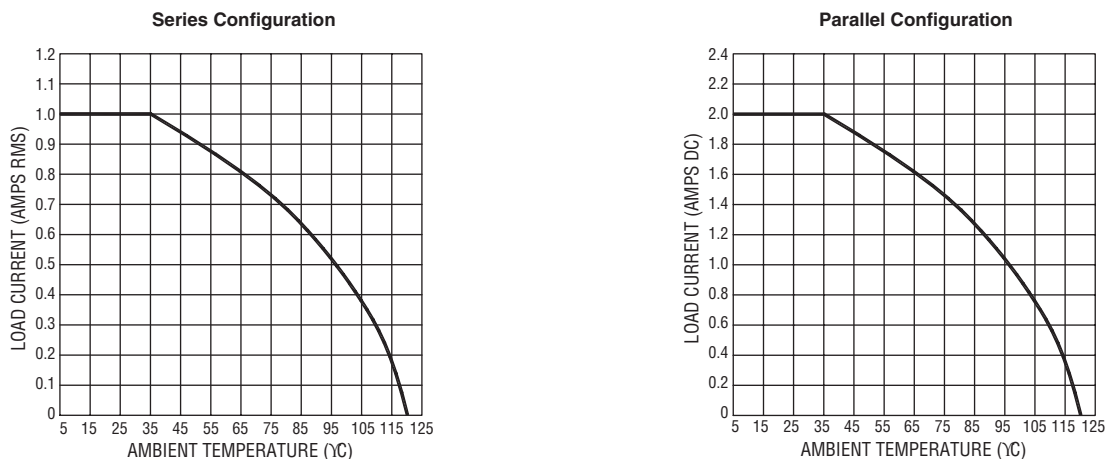


Figure 3 - Turn-on and Turn-off Timing

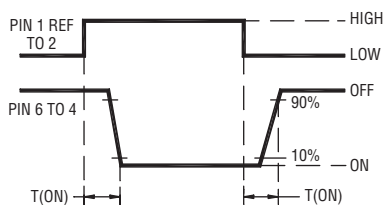


Figure 4 - Functional Block Diagram

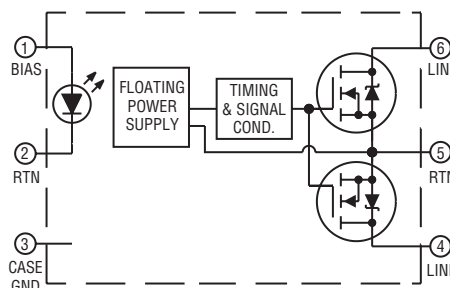
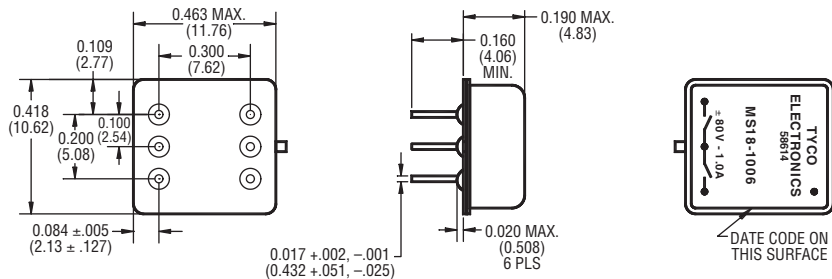


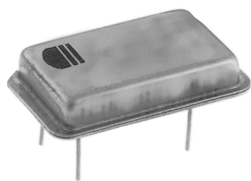
Figure 5 - Outline Dimensions



Notes

1. An external resistor must be in series with the input at all times.
2. Do not ramp input current. Input transition should be <1.0ms.
3. Input current/series resistor calculation (Approx.): $I_{(input)} = V_{IN} - V_{DROF}/R_{SERIES}$.
4. Unless otherwise specified parametric testing is accomplished at 25ma input current.
5. To calculate $R_{DS(ON)}$ for temperatures other than 25°C, use the following equation: $T_{(TEMP)} = (R_{DS(ON)} \text{ at } +25^{\circ}\text{C}) \cdot e^{(x \cdot \Delta T)}$ where $x = 0.0065$.
6. Inductive loads must be diode suppressed.
7. Continuous load current is rated under conditions of still air.
8. Load may be connected to either side of relay, sink or source modes.
9. Reverse polarity >5Vdc may cause permanent damage
10. Acceptance testing is accomplished in the series (bi-directional) mode.
11. DSCC part numbers 89116-002 & 89116-004 are also available.

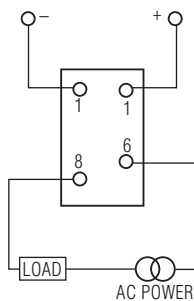
JDS9 Series, AC Relays, 2A/250Vrms Rating



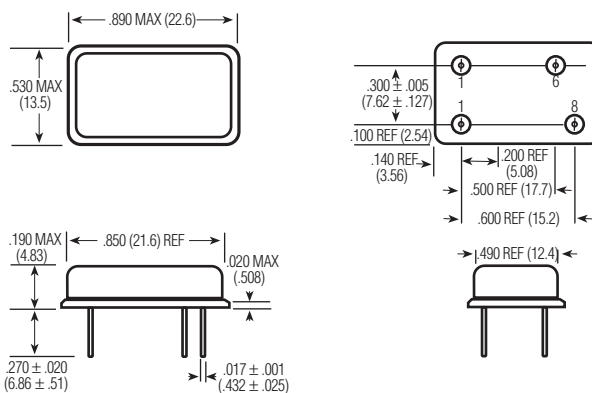
Input Characteristics
Input Voltage Range — 3.8 – 32 Vdc
Pick-up Voltage — 3.8 Vdc
Dropout Voltage — 1.5 Vdc
I/O Dielectric — 1500 Vrms

Output Characteristics
Max. Output Current (Continuous, 25°C) — 2 Arms
Max. Output Voltage — 250 Vrms
Peak Over Voltage Rating — 500 Vpk
Frequency Range — 40 – 440 Hz
Zero Switch Window — 15 Vpk
Thermal Resistance —
 Junction to Ambient — 65°C/Watt
 Junction to Case — 15°C/Watt

Environmental Characteristics
Shock — 1500 G's, 0.5 ms.
Vibration — 30 G's, 10 to 3000 Hz
Operating Ambient Temperature — -55 to +110°C



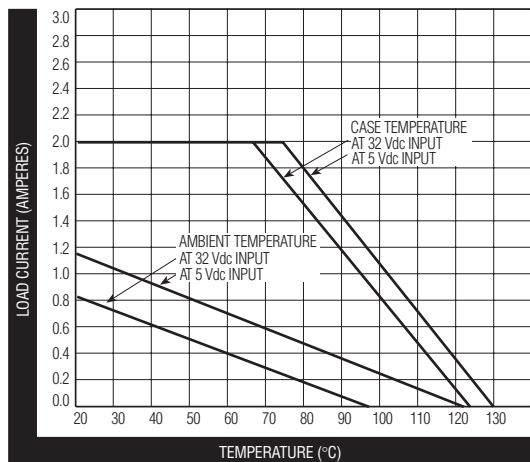
Terminal View



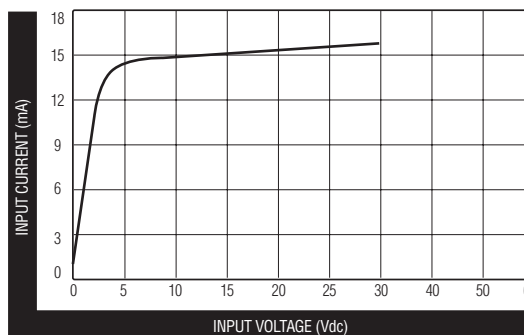
Product Facts

- Hermetically sealed
- Thick film hybrid construction
- Optically isolated
- Zero voltage turn-on
- Qualified to MIL-R-28750/9

Screening levels: Y level for high reliability applications. P/NJS9-1Y
 W level for general purpose applications. P/NS9-1W



JDS9 Max. Output Current vs. Temperature



JDS9 Typical Input Current vs. Input Voltage

10
 KILOVAC Solid State Relays

JDS9 Series, AC Relays, 2A/250Vrms Rating (Continued)

Electrical Specifications (-55°C to +105°C unless otherwise specified)

| Input | |
|---|-------------------------|
| Input supply voltage range (Vcc) | 3.8 - 32 Vdc |
| Input current (max.) @ 5Vdc | 15mA _{dc} |
| Must turn-on voltage | 3.8V _{dc} |
| Must turn-off voltage | 1.5V _{dc} |
| Reverse voltage protection | -32V _{dc} |
| I/O | |
| Dielectric strength (min.) | 1,500V rms/60 Hz. |
| Insulation resistance (min.) @ 500Vdc | 10 ⁹ ohms |
| Capacitance (max.) | 10pF |
| Output | |
| Output current rating (max.) | 2A rms (Fig. 2, Note 1) |
| Surge current (max.), 16ms @ 25°C (max.) | 8A pk (Fig. 1, Note 3) |
| Continuous load voltage (max.) | 250V rms |
| Transient blocking voltage (max.) | 500V pk |
| Frequency range | 40 - 440 Hz. |
| Output voltage drop (max.) @ 1A load current | 1.5V rms |
| Off-state leakage current (max.) @ 250V rms/400 Hz. | 1mA rms |
| Turn-on time (max.) | 1/2 cycle |
| Turn-off time (max.) | 1 cycle |
| Off-state dv/dt (min.), with snubber | 200V /μs (Note 2) |
| Zero voltage turn-on window (max.) | 10V |
| Wave distortion (max.) | 4V rms |
| Output chip junction temperature (max.) | 130°C |
| Thermal resistance (max.), junction to ambient | 65°C/W |
| Thermal resistance (max.), junction to case | 15°C/W |

Notes

1. Operation at elevated load currents up to 2 amps is dependent on the use of suitable heatsink to maintain case temperature.
2. Recommended output snubber: R = 100 ohms (1/2 W), C = .01μF (600V).
3. Heating of output chip during and after a surge may cause loss of output blocking capability until junction temperature falls below maximum rating.

PS12 Series High Performance Solid State Relays For AC Loads up to 10A @ 250Vrms

Product Facts

- Approved to DSCC drawing 86031
- Optically coupled all solid state relay
- TTL compatible input
- Zero voltage turn-on for low EMI
- Custom power package with screw terminals



The PS12 series solid state relay is designed for AC power switching up to 10 amps at 250Vrms. The circuit employs back-to-back SCRs with zero voltage turn-on for reliable switch-

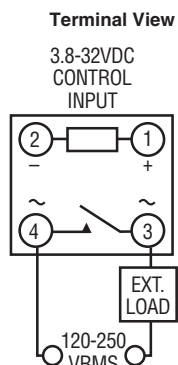
ing of resistive or reactive loads. TTL compatible input circuitry is optically isolated to 1,500Vrms from the AC load circuit. The relay is offered in two versions: the PS12-1Y with "Y" level

screening per MIL-PRF-28750D, and the PS12-1W screened per Tyco Electronics specifications for KILOVAC relays, equivalent to former "W" level of Mil-R-28750.

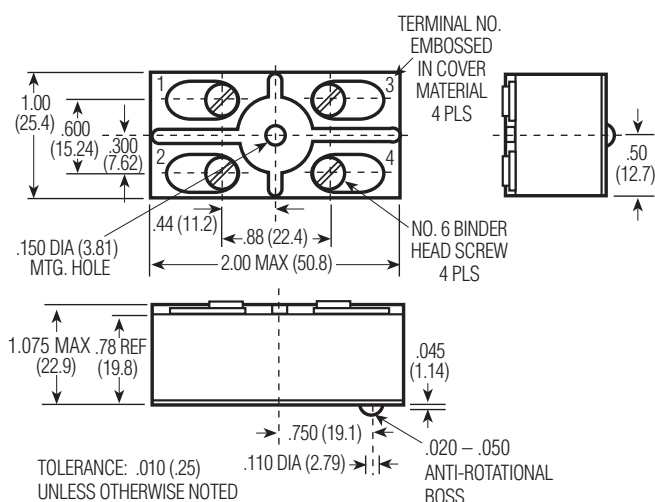
10
KILOVAC Solid State Relays

| KILOVAC Part Number | DSCC Part Number | Screening Level |
|---------------------|------------------|-----------------|
| PS12-1Y | 86031-001 | Y |
| PS12-1W | N/A | W |

Circuit Diagram



Outline Drawing



PS12 Series High Performance Solid State Relays For AC Loads up to 10A @ 250Vrms (Continued)

Environmental Characteristics

Ambient Temperature Range —

Operating — -55°C to +95°C
Storage — -55°C to +110°C

Vibration Resistance —

30 G's, 78-2,000 Hz

Shock Resistance —

100 G's, 6 ms pulse

Constant Acceleration Resistance —

100 G's

Mechanical Characteristics

Weight (max.) —

3 oz. (85 grams)

Materials —

Case — Plastic, self-extinguishing, epoxy filled

Terminals — Brass, nickel-plated

Base Plate — Aluminum

NOTE: Do not exceed 80 in-oz when tightening screws.

Electrical Specifications (-55°C to +95°C unless otherwise specified)

Input

| | |
|----------------------------------|--------------|
| Input supply voltage range (Vcc) | 3.8 - 32 Vdc |
| Input current (max.) @ 5Vdc | 16mAdc |
| Must turn-on voltage | 3.8Vdc |
| Must turn-off voltage | 1Vdc |
| Reverse voltage protection | -32Vdc |

I/O

| | |
|---------------------------------------|----------------------|
| Dielectric strength (min.) | 1,500V rms/60 Hz. |
| Insulation resistance (min.) @ 500Vdc | 10 ⁸ ohms |
| Capacitance (max.) | 15pF |

Output

| | |
|---|--------------------------|
| Output current rating (max.) | 10A rms (Fig. 2, Note 1) |
| Surge current (max.) | 100A pk (Fig. 1, Note 2) |
| Continuous load voltage (max.) | 250V rms |
| Transient blocking voltage (max.) | 460V pk |
| Frequency range | 45 - 440 Hz. |
| Output voltage drop (max.) @ 25A load current | 1.5V rms |
| Off-state leakage current (max.) @ 220V rms/400 Hz. | 9mA rms |
| Turn-on time (max.) | 1/2 cycle |
| Turn-off time (max.) | 1 cycle |
| Off-state dv/dt (min.), with snubber | 200V / μ s (Note 3) |
| Zero voltage turn-on window (max.) | \pm 15V pk |
| Output chip junction temperature (max.) | 125°C (Note 1) |
| Thermal resistance (max.), junction to ambient | 11.5°C/W |
| Thermal resistance (max.), junction to case | 2.0°C/W |
| Fusing I ² T, 1 ms (max.) | 150A ² s |
| Load power factor (min.) | 0.2 |
| Power dissipation (max.) | 1.5W/A |

Notes

1. Operation at elevated load currents up to 10 amps is dependent on the use of suitable heatsink to limit junction temperature.
2. Heating of output chips during and after a surge may cause loss of output blocking capability until junction temperature falls below maximum rating.
3. Internal snubber network is provided across output chips.

Figure 1 - Peak Surge Current vs. Surge Current Duration

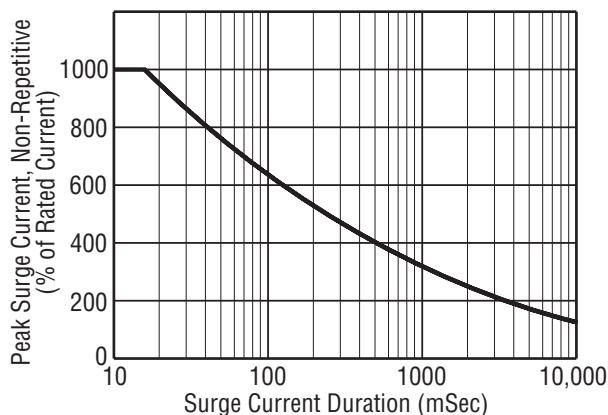
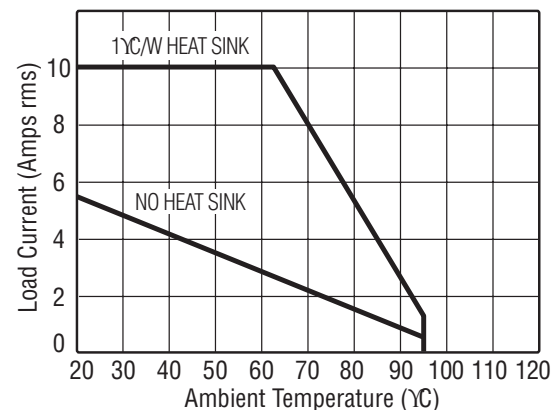


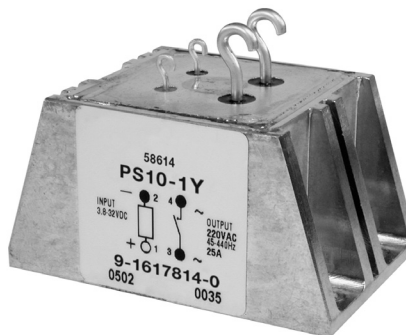
Figure 2 - Load Current vs. Temperature



PS10 Series High Performance Solid State Relays For AC Loads up to 25A @ 250Vrms

Product Facts

- Optically coupled all solid state relay
- TTL compatible input
- Zero voltage turn-on for low EMI
- Custom power package



The PS10 series solid state relay is designed for AC power switching up to 25 amps at 250Vrms. The circuit employs back-to-back photo SCRs with zero voltage turn-on for reliable

switching of resistive or reactive loads. TTL compatible input circuitry is optically isolated to 1,500Vrms from the AC load circuit. The relay is offered in two versions: the PS10-1Y with a maximum

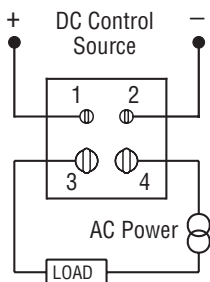
zero voltage turn-on window of 15 volts (preferred version for resistive loads), and the PS10-2Y with a maximum window of 40 volts (preferred version for reactive loads).

10
KILOVAC Solid State Relays

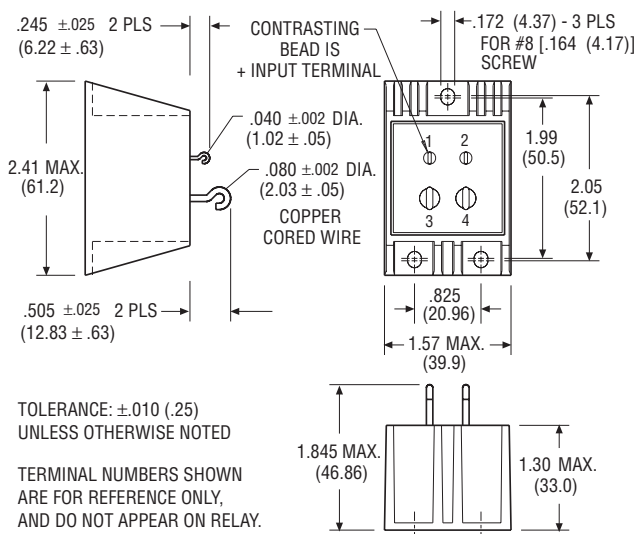
| KILOVAC Part Number | TE Part Number | Zero Crossing Window |
|---------------------|----------------|----------------------|
| PS10-1Y | 9-1617814-0 | 15 V pk max. |
| PS10-2Y | 1617815-3 | 40 V pk max. |

Circuit Diagram

Terminal View



Outline Drawing



PS10 Series High Performance Solid State Relays For AC Loads up to 25A @ 250Vrms (Continued)

Environmental Characteristics

Ambient Temperature Range —

Operating — -55°C to +110°C

Storage — -55°C to +125°C

Vibration Resistance —

30 G's, 10-3,000 Hz

Shock Resistance —

1,500 G's, 0.5 ms pulse

Constant Acceleration Resistance

(Y1 axis) —

5,000 G's

Mechanical Characteristics

Weight (max.) —

6 oz. (170 grams)

Materials —

Case — Aluminum, hot tin dipped

Terminals — Copper cored wire, gold plated

Electrical Specifications (-55°C to +105°C unless otherwise specified)

Input

| | |
|----------------------------------|------------|
| Input supply voltage range (Vcc) | 4 - 32 Vdc |
| Input current (max.) | 16mA dc |
| Must turn-on voltage | 4Vdc |
| Must turn-off voltage | 1Vdc |
| Reverse voltage protection | -32Vdc |

I/O

| | |
|---------------------------------------|----------------------|
| Dielectric strength (min.) | 1,500Vrms/60 Hz. |
| Insulation resistance (min.) @ 500Vdc | 10 ⁹ ohms |
| Capacitance (max.) | 20pF |

Output

| | |
|--|-------------------------|
| Output current rating (max.) | 25Arms (Fig. 2, Note 1) |
| Surge current (max.) | 80A pk (Fig. 1, Note 2) |
| Continuous load voltage (max.) | 250Vrms |
| Transient blocking voltage (max.) | 500V pk |
| Frequency range | 45 - 440 Hz. |
| Output voltage drop (max.) @ 25A load current | 1.5Vrms |
| Off-state leakage current (max.) @ 220Vrms/400 Hz. | 10mArms |
| Turn-on time (max.) | 1/2 cycle |
| Turn-off time (max.) | 1 cycle |
| Off-state dv/dt (min.), with snubber | 200V / μ s (Note 3) |
| Zero voltage turn-on window (max.), PS10-1Y | 15V pk |
| Zero voltage turn-on window (max.), PS10-2Y | 40V pk |
| Waveform distortion (max.) | 4Vrms |
| Output chip junction temperature (max.) | 125°C (Note 4) |
| Thermal resistance (max.), junction to ambient | 6.8°C/W |
| Thermal resistance (max.), junction to case | 1.2°C/W |

Notes

1. Operation at elevated load currents up to 25 amps is dependent on the use of suitable heatsink to maintain case temperature per Fig. 2.
2. Heating of output chips during and after a surge may cause loss of output blocking capability until junction temperature falls below maximum rating.
3. Internal snubber network is provided across output chips.
4. Case temperature measurement point is center of mounting surface.

Figure 1 - Peak Surge Current vs. Surge Current Duration

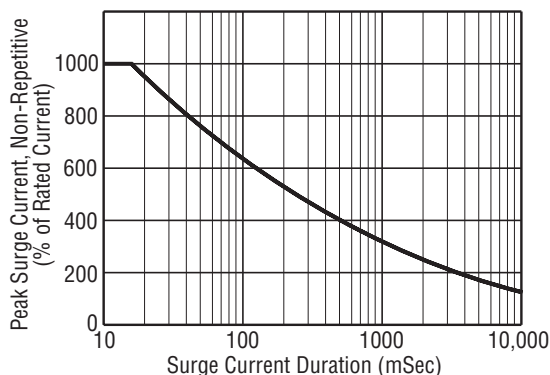
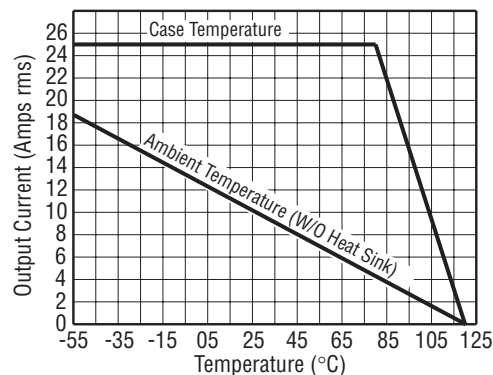


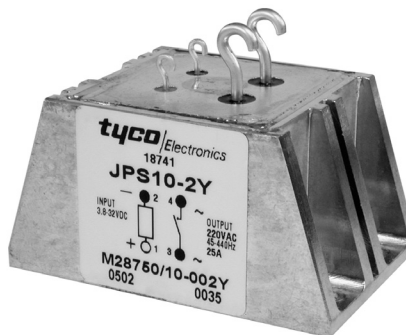
Figure 2 - Load Current vs. Temperature



JPS10 Series High Performance Solid State Relays For AC Loads up to 25A @ 250Vrms

Product Facts

- Qualified to MIL-PRF-28750D (Mil Part Numbers M28750/10-001Y and M28750/10-002Y)
- Optically coupled all solid state relay
- TTL compatible input
- Zero voltage turn-on for low EMI
- Custom power package



The JPS10 series solid state relay is designed for AC power switching up to 25 amps at 250Vrms. The circuit employs back-to-back photo SCRs with zero voltage turn-on for reliable switching of resistive or

reactive loads. TTL compatible input circuitry is optically isolated to 1,500Vrms from the AC load circuit. The relay is offered in two versions: the JPS10-1Y with a maximum zero voltage turn-on window of 15

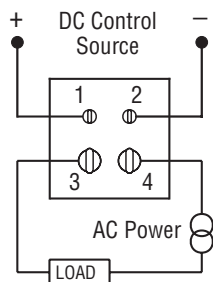
volts (preferred version for resistive loads), and the JPS10-2Y with a maximum window of 40 volts (preferred version for reactive loads).

10
KILOVAC Solid State Relays

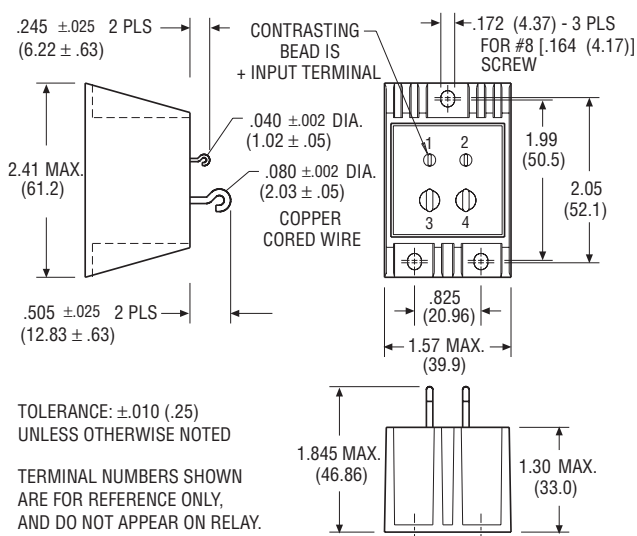
| KILOVAC Part Number | Military Part Number | Zero Crossing Window |
|---------------------|----------------------|----------------------|
| JPS10-1Y | M28750/10-001Y | 15 V pk max. |
| JPS10-2Y | M28750/10-002Y | 40 V pk max. |

Circuit Diagram

Terminal View



Outline Drawing



JPS10 Series High Performance Solid State Relays For AC Loads up to 25A @ 250Vrms (Continued)

Environmental Characteristics

Ambient Temperature Range —

Operating — -55°C to +110°C
Storage — -55°C to +125°C

Vibration Resistance —

30 G's, 10-3,000 Hz

Shock Resistance —

1,500 G's, 0.5 ms pulse

Constant Acceleration Resistance

(Y1 axis) —

5,000 G's

Mechanical Characteristics

Weight (max.) —

6 oz. (170 grams)

Materials —

Case — Aluminum, hot tin dipped
Terminals — Copper cored wire, gold plated

Electrical Specifications (-55°C to +105°C unless otherwise specified)

Input

| | |
|----------------------------------|------------|
| Input supply voltage range (Vcc) | 4 - 32 Vdc |
| Input current (max.) | 16mAdc |
| Must turn-on voltage | 4Vdc |
| Must turn-off voltage | 1Vdc |
| Reverse voltage protection | -32Vdc |

I/O

| | |
|---------------------------------------|----------------------|
| Dielectric strength (min.) | 1,500Vrms/60 Hz. |
| Insulation resistance (min.) @ 500Vdc | 10 ⁹ ohms |
| Capacitance (max.) | 20pF |

Output

| | |
|--|-------------------------|
| Output current rating (max.) | 25Arms (Fig. 2, Note 1) |
| Surge current (max.) | 80A pk (Fig. 1, Note 2) |
| Continuous load voltage (max.) | 250Vrms |
| Transient blocking voltage (max.) | 500V pk |
| Frequency range | 45 - 440 Hz. |
| Output voltage drop (max.) @ 25A load current | 1.5Vrms |
| Off-state leakage current (max.) @ 220Vrms/400 Hz. | 10mArms |
| Turn-on time (max.) | 1/2 cycle |
| Turn-off time (max.) | 1 cycle |
| Off-state dv/dt (min.), with snubber | 200V / μ s (Note 3) |
| Zero voltage turn-on window (max.), JPS10-1Y | 15V pk |
| Zero voltage turn-on window (max.), JPS10-2Y | 40V pk |
| Waveform distortion (max.) | 4Vrms |
| Output chip junction temperature (max.) | 125°C (Note 4) |
| Thermal resistance (max.), junction to ambient | 6.8°C/W |
| Thermal resistance (max.), junction to case | 1.2°C/W |

Notes

1. Operation at elevated load currents up to 25 amps is dependent on the use of suitable heatsink to maintain case temperature per Fig. 2.
2. Heating of output chips during and after a surge may cause loss of output blocking capability until junction temperature falls below maximum rating.
3. Internal snubber network is provided across output chips.
4. Case temperature measurement point is center of mounting surface.

Figure 1 - Peak Surge Current vs. Surge Current Duration

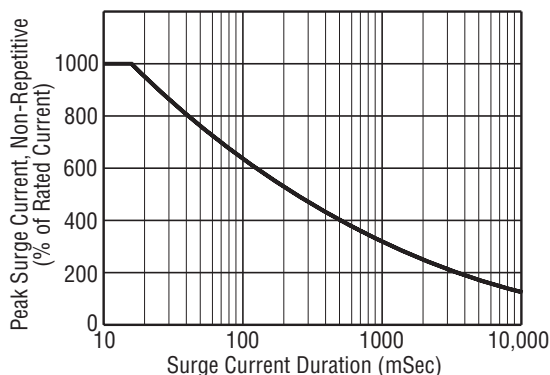


Figure 2 - Load Current vs. Temperature

