

TSYS03

Digital Temperature Sensor

Product Description

The TSYS3 is a miniature digital temperature sensor that provides factory calibrated highly accurate temperature data.

The device contains a durable temperature sensor element, A/D converter, and microcontroller to manage data communications via an I²C interface.

TSYS3 is available in a TDFN8 or a XDFN6 package to easily adapt to the space available on a PC board. These packages are very small and have low thermal mass which provides a quick response to temperature changes.

The operating and measurement temperature range is -40 to +125°C with a resolution of ±0.01°C.

Operating and sleep currents are extremely low making this sensor ideal for mobile and battery power applications.

Features

- High Accuracy ±0.5°C @ Temp.: 0°C ... +60°C
- Adjustment of high accuracy temperature range on request
- Low Supply Current < 5 µA (standby < 0.4 µA)
- I²C Interface up to 1MHz
- Small IC-Package TDFN8 2.5mm x 2.5mm and XDFN6 1.5mm X 1.5mm
- Operating Temperature Range: -40°C ... +125°C
- **Programmable I2C Address**

Applications

- Industrial Control
- Replacement of Precision RTDs, Thermistors and NTCs
- Heating / Cooling Systems
- HVAC
- Medical probes and patient monitoring
- Weather Stations
- Fitness watches and wearables
- Consumer appliances

Absolute Maximum Ratings

Absolute maximum ratings are limiting values of permitted operation and should never be exceeded under the worst possible conditions either initially or consequently. If exceeded by even the smallest amount, instantaneous catastrophic failure can occur. And even if the device continues to operate satisfactorily, its life may be considerably shortened.

Parameter	Symbol	Condition	Min	Typ	Max	Unit
Supply Voltage	V_{DD}	---	-0.3	---	+5.5	V
Operating Temperature	T_{op}	---	-40	---	+125	°C
Storage temperature	T_{stor}	---	-55	---	+150	°C
ESD rating	ESD	Human Body Model (HBM) pin to pin incl. V_{DD} & GND	-4	---	+4	kV
Humidity	Hum	Non-condensing	0	---	95	RH

Operating Conditions

Parameter	Symbol	Condition	Min	Typ	Max	Unit
Operating Supply Voltage	V_{DD}	stabilized	2.4	3.3	5.5	V
Supply Current	I_{DD}	1 sample per second	---	5	---	μA
Standby current	I_s	No conversion, $V_{DD} = 5.0V$ $T = +25^{\circ}C$ $T = +85^{\circ}C$ $T = +125^{\circ}C$	---	0.16 0.32 1.02	0.34 1.32 6.27	μA
Peak Supply Current	I_{DD}	$V_{DD} = 5.0V$ $T = 25^{\circ}C$ $T = -40^{\circ}C \dots +125^{\circ}C$	345 327	402	486 515	μA
Conversion time	T_{CONV}	---	---	12	---	ms
Serial Data Clock I2C	F_{SCL}	---	---	---	1	MHz
VDD Capacitor	---	Place close to the chip	100		---	nF

Operational Characteristics

If not otherwise noted, 3.3V supply voltage is applied.

Parameter	Symbol	Condition	Min	Typ	Max	Unit
Temp. Measurement Range	T_{RANG}	---	-40	---	125	°C
Accuracy 1	T_{ACC1}	$0^{\circ}C < T < +60^{\circ}C$ $V_{DD} = 3.2V - 3.4V$	-0.5	---	+0.5	°C
Accuracy 2	T_{ACC2}	$60^{\circ}C < T < +85^{\circ}C$ $V_{DD} = 3.2V - 3.4V$	-0.7	---	+0.7	°C
Accuracy 3	T_{ACC3}	$-25^{\circ}C < T < +105^{\circ}C$ $V_{DD} = 3.2V - 3.4V$	-1.0	---	+1.0	°C
Accuracy 4	T_{ACC4}	$-40^{\circ}C < T < +125^{\circ}C$ $V_{DD} = 3.2V - 3.4V$	-1.5	---	+1.5	°C
PSRR	---	$V_{DD} = 2.4 - 5.5$ $T = 25^{\circ}C, C = 100nF$	---	---	0.1	°C
Self-Heating	SH	10 samples/s, 60s, still air	---	---	+0.1	°C

Accuracy

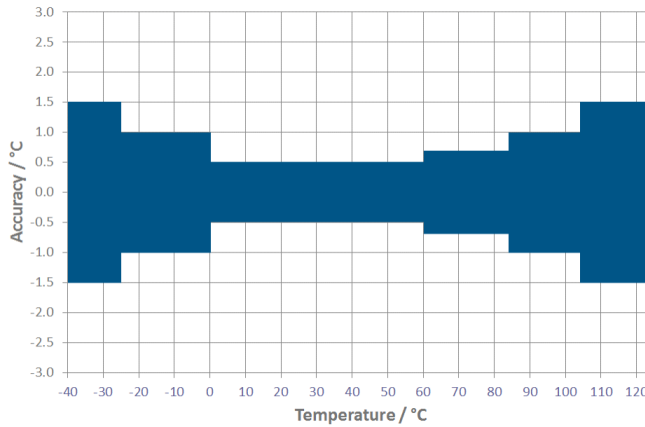

Analogue to Digital Converter

Parameter	Symbol	Condition	Min	Typ	Max	Unit
Resolution	---	---	---	16	---	bit
Conversion Time	t_c	---	---	12	---	ms

Digital Inputs (SCLK, SDA)

Parameter	Symbol	Condition	Min	Typ	Max	Unit
Input High Voltage	V_{IH}	$V_{DD} = 3.0 \dots 5.5V$	$0.7 V_{DD}$	---	V_{DD}	V
Input Low Voltage	V_{IL}	$V_{DD} = 3.0 \dots 5.5V$	$0.0 V_{DD}$	---	$0.3 V_{DD}$	V
Input leakage Current	I_{leak_25} I_{leak_85}	$T = 25^\circ C$ $T = 85^\circ C$	---	0.01 0.25	0.14 1.40	μA
Input Capacitance	C_{IN}	---	---	---	6	pF

Digital Outputs (SDA)

Parameter	Symbol	Condition	Min	Typ	Max	Unit
Output High Voltage	V_{OH}	$I_{Source} = 1mA$	$0.8 V_{DD}$	---	V_{DD}	V
Output Low Voltage	V_{OL}	$I_{Sink} = 1mA$	$0.0 V_{DD}$	---	$0.2 V_{DD}$	V

Connection Diagram

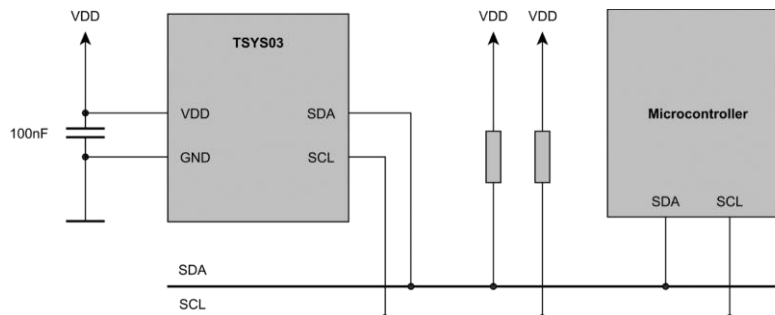

Pin Function Table

TDFN Package

Pin	Name	Type	Function
1	V _{DD}	Power	Supply Voltage
2	SCL	Digital Input	I ² C: Serial Data Clock
3	SDA	Digital Input / Output	I ² C Data Input / Output
4	VSS	Power	Ground
5 ... 8	NC	---	Not connected / Do not connect

XDFN Package

Pin	Name	Type	Function
1	NC	---	Not connected / Do not connect
2	VSS	Power	Ground
3	SDA	Digital Input / Output	I ² C Data Input / Output
4	SCL	Digital Input	I ² C: Serial Data Clock
5	V _{DD}	Power	Supply Voltage
6	NC	---	Not connected / Do not connect

I²C Interface

An I²C communication message starts with a start condition and it is ended by a stop condition. Each command consists of two bytes: the address byte and command byte.

I²C Address

The standard I²C address is 0x40 (0b1000000x). Every sensor will respond to this address. But the sensor can also react to a second, alternative I²C address.

It is possible to do a one-time subsequent writing of an alternative static I²C address. This leads to a wrong memory CRC but the sensor is still functional.

The alternative address could be written to the sensor already during production. There won't be a wrong CRC at the end in this case.

It is also possible to write an alternative I²C address to the sensor during operation. This address is temporally and is overwritten during a software reset or a hardware restart.

Further information on writing the alternative I²C address are given in the Application Note.

Commands

There are four commands:

- Reset
- Read Serial Number
- Start Conversion
- Read ADC

Command	Hex
Reset	0x1E
Read Serial Number	0x0A
Start Conversion	0x46
Read ADC	0x00

Reset Sequence

The reset of TSYS03 can be sent at any time. When SDA line is blocked by an undefined state the only way to get the TSYS03 to work is to send a power on reset or several SCL cycles. This is not needed when the last command was not a conversion.

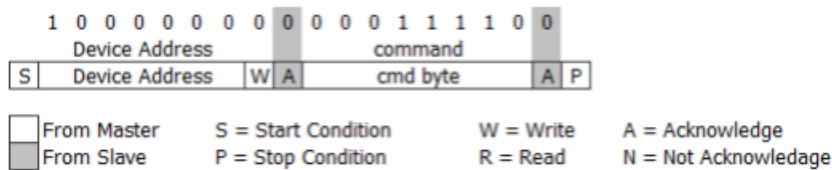

Start Conversion

A conversion must be started and conducted before the ADC result can be read.

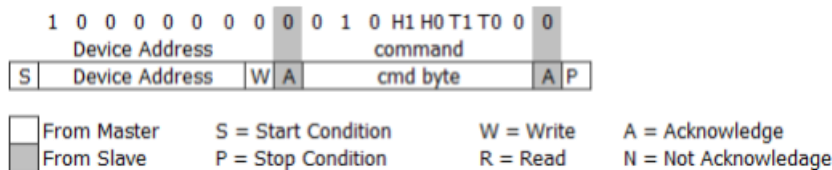

Reading ADC Result

The temperature reprinting ADC result is read including CRC checksum.

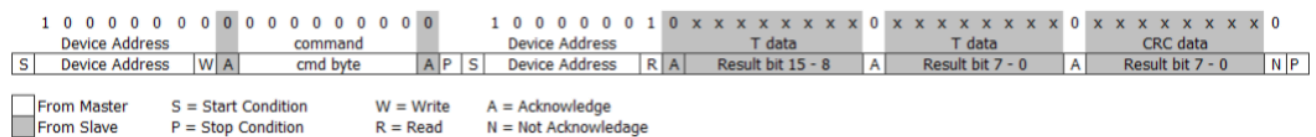

Read Serial Number

The serial number is written to non-volatile memory along with other values during production. It represents the chip position on the production wafer.

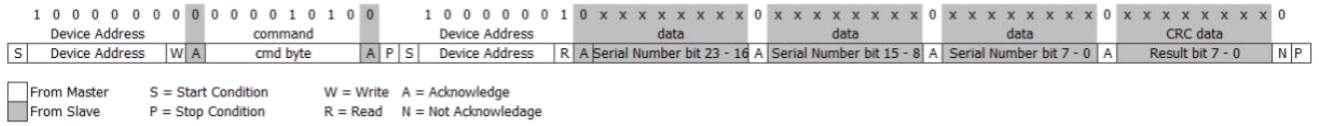

CRC byte

The CRC byte can be used to check for bad data.

It is determined over the entire data using polynomial 0x31.

Temperature Calculation

TEMPERATURE POLYNOMIAL

ADC: ADC Result

$$T / ^\circ\text{C} = -40^\circ\text{C} + \text{ADC} \times 165 / (2^{16}-1)$$

EXAMPLE

ADC16: 26682 (0x683A)

$$T / ^\circ\text{C} = -40 + 26682 \times 165 / (2^{16}-1)$$

$$T / ^\circ\text{C} = 27.18^\circ\text{C}$$

TSYS03

Digital Temperature Sensor

Dimensions

TDFN 2.5mm X 2.5mm

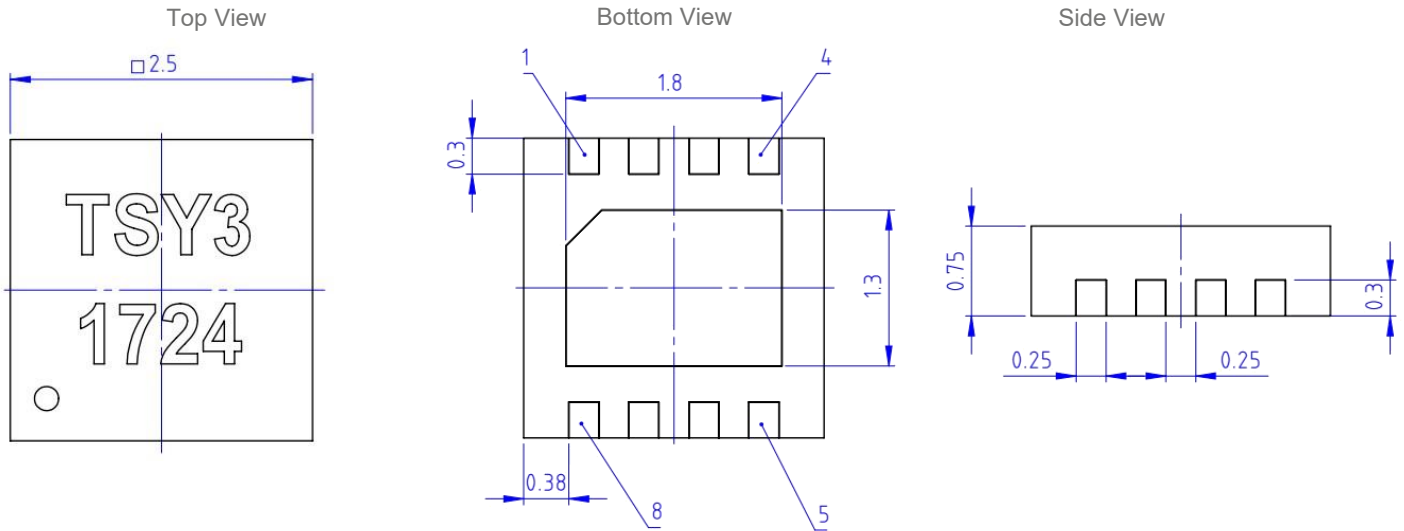

XDFN 1.5mm X 1.5mm

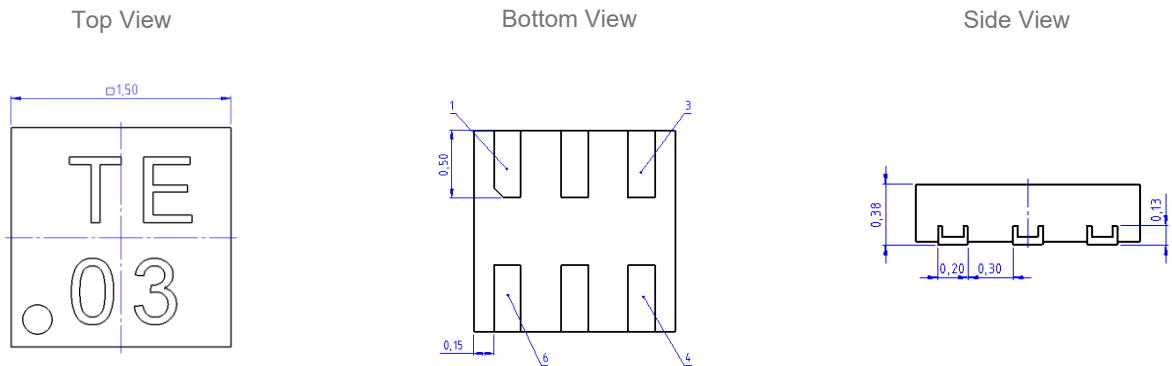

Marking

Line	TDFN-Package		XDFN-Package	
	Description	Text	Description	Text
1	Product Name	TSY3	Product Name	TE
2	Pin 1 Dot, Date Code YYWW	1724	Pin 1 Dot, Product Name	03

TSYS03

Digital Temperature Sensor

Order Information

Further customer specific adaptations are available on request. Please refer to the table below for part name, description and order information.

Part Number	Part Description	Comment
20011957-00	TSYS03 TEMP SENSOR TDFN8 2.5X2.5MM I2C	Digital Temperature Sensor, TDFN8, I2C Interface
20011957-01	TSYS03 TEMP SENSOR XDFN6 1.5X1.5MM I2C	Digital Temperature Sensor, XDFN6, I2C Interface

EMC

Due to the use of these modules for OEM application no CE declaration is done. Especially line coupled disturbances like surge, burst, HF etc. cannot be removed by the module due to the small board area and low price feature. There is no protection circuit against reverse polarity or over voltage implemented. The module will be designed using capacitors for blocking and ground plane areas in order to prevent wireless coupled disturbances as good as possible.

NORTH AMERICA

Measurement Specialties, Inc.,
a TE Connectivity Company
1711 139th Lane NW
Andover, MN 55304
Tel: +1 763 689 4870
Fax: +1 763 689 5033

customercare.ando@te.com

EUROPE

TE Connectivity Sensors Germany GmbH
Hauert 13
44227 Dortmund
Germany
Tel: +49-231-9740-0
Fax: +49-231-9740-20

CustomerCare.dtm@te.com

ASIA

Measurement Specialties (China), Ltd.,
a TE Connectivity Company
No. 368 Wulian 1st Road
Gongxing Town
Shuangliu, Chengdu
Sichuan, 610200
China
Tel: +86 (0) 28 8573 9088
Fax: +86 (0) 28 8573 9070
customercare.chdu@te.com

te.com/sensorsolutions

Measurement Specialties, Inc., a TE Connectivity company.

Measurement Specialties, MEAS, TE Connectivity, TE Connectivity (logo) and EVERY CONNECTION COUNTS are trademarks. All other logos, products and/or company names referred to herein might be trademarks of their respective owners.

The information given herein, including drawings, illustrations and schematics which are intended for illustration purposes only, is believed to be reliable. However, TE Connectivity makes no warranties as to its accuracy or completeness and disclaims any liability in connection with its use. TE Connectivity's obligations shall only be as set forth in TE Connectivity's Standard Terms and Conditions of Sale for this product and in no case will TE Connectivity be liable for any incidental, indirect or consequential damages arising out of the sale, resale, use or misuse of the product. Users of TE Connectivity products should make their own evaluation to determine the suitability of each such product for the specific application.

© 2020 TE Connectivity Ltd. family of companies All Rights Reserved.