

## Metal Element Current Sense Resistor

### ULR Series

- Robust metal strip able to withstand high temperature and high current.
- Low TCR and Inductance
- Resistance Range from 0.1mΩ to 10mΩ
- Includes anti-sulphur types
- AEC-Q200
- Higher wattage devices feature PCB clearance gap to maximize thermal performance

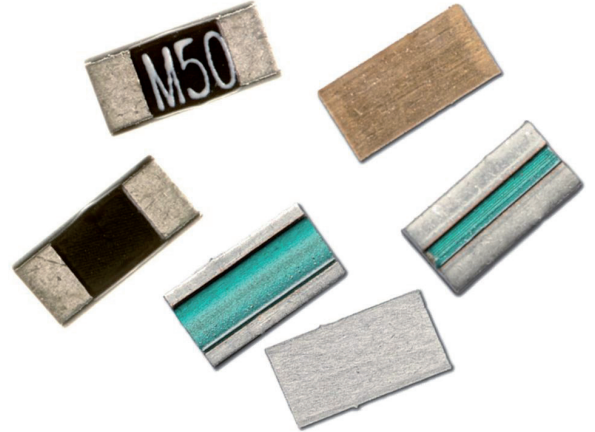

All parts are Pb-free and comply with EU Directive 2011/65/EU amended by (EU) 2015/863 (RoHS3)

### Electrical Data

Type	Size	Coating	Power Rating @80°C (W)	Standard Resistance Value mΩ <sup>1</sup>	TCR (ppm/°C)	Tolerance (%)	Dielectric Withstanding Voltage (V)	Ambient Temperature (°C)
ULRG1 / ULR1S	1206	Green Underside	1	0.2, 0.25, 0.3, 0.4, 0.5, 0.6	200	1, 5	N/A	-55 to +170
ULRG15 / ULR15S	2010			0.75, 1, 1.2, 2, 2.5, 3, 3.5, 4, 5, 5.5, 6, 7, 8, 9, 10	50			
ULR2N	1020		2	0.2, 0.25, 0.3, 0.4, 0.5	150			
				0.75, 1, 1.5, 2, 2.5, 3, 4, 5, 5.5, 6, 7, 8, 9, 10	50			
ULRG2 / ULR2	2512		2	1	300			
				1.5, 2, 2.5, 3	170			
ULRG25 / ULR25	2512		2.5	6.5, 7, 7.5, 8, 9, 10	50			
ULRG3 / ULR3				3.5, 4, 4.5, 5, 5.5, 6				
ULR3N	1225		3	0.15, 0.25, 0.3, 0.4, 0.5, 0.75	150			
				1, 1.5, 2, 2.5, 3	50			
		0.1		500				
		0.2, 0.25, 0.3, 0.4		350				
		0.5		300				
ULRB1 / ULR1	2512	1	0.7, 0.75, 0.8, 0.9, 1.0	250				
			1.5, 2.0, 2.5, 3.0	100				
			0.5, 0.75, 1, 1.5, 2	50				
			2.5, 3, 3.5	150				
			4, 4.5, 5, 5.5, 10	100				
ULRB2 / ULR2	2512	2	6, 6.5, 7, 7.5	75				
			0.5, 0.75, 1, 1.5, 2	50				
			2.5, 3	150				

**Notes:** 1. For higher resistance values please refer to LRMA series.

### Performance Data

AEC-Q200 Table 7		Method	ΔR%	Max. (add R0005)		
ref.	Test <sup>1</sup>			Black	Green Underside	
					1206 & 2010	1020, 2512 & 1225
3	High Temp. Exposure *	MIL-STD-202 Method 108	ΔR%	1		
4	Temperature Cycling	JESD22 Method JA-104	ΔR%	0.5	1	
6	Moisture Resistance	MIL-STD-202 Method 106	ΔR%	1		
7	Biased Humidity	MIL-STD-202 Method 103	ΔR%	1		
8	Operational Life (Cyclic Load) *	MIL-STD-202 Method 108	ΔR%	1		
14	Vibration	MIL-STD-202 Method 204	ΔR%	0.5	1	
15	Resistance to Soldering Heat *	MIL-STD-202 Method 210	ΔR%	0.5	1	
16	Thermal Shock *	MIL-STD-202 Method 107	ΔR%	0.5	1	
18	Solderability	J-STD-002		>95% coverage		
21	Board Flex	AEC-Q200-005	ΔR%	0.5	1	
22	Terminal Strength	AEC-Q200-006	ΔR%	0.25	1	
	Short Term Overload *	5 x Pr for 5s	ΔR%	0.5	1	
	Resistance to Sulphur-Bearing Gas <sup>2</sup>	EIA-977	ΔR%	N/A	1	

**Notes:** 1. Full AEC-Q200 qualification applies to 2512 size. The 1206 and 2010 sizes have received the tests marked \*.  
2. Resistance to sulphur bearing gas has been tested for green underside construction only.

#### General Note

TT Electronics reserves the right to make changes in product specification without notice or liability.  
All information is subject to TT Electronics' own data and is considered accurate at time of going to print.

## ULR Series

### Physical Data

Dimensions(mm) and weight (mg)							
Size	Coating	Values	L (±0.25)	W	T (±0.2)	D	Wt (nom)
1206	Green Underside	0.2, 0.25	3.2	1.6 ±0.3	1.0	1.5 ±0.25	25
		0.3, 0.4				1.4 ±0.25	
		0.5, 0.6		1.6 ±0.1	0.6	1.35 ±0.25	20
		0.75				1.23 ±0.25	
		1, 1.2, 3.5, 4, 5, 5.5, 6				1.1 ±0.25	
		2, 2.5, 3, 10				0.6 ±0.25	
		7, 8, 9				0.9 ±0.25	
2010		0.2	2.54 ±0.3	1.0	2.34 ±0.25	50	
		0.25			2.24 ±0.25		
		0.3			2.04 ±0.25		
		0.4			1.84 ±0.25		
		0.5	2.54 ±0.15	0.6	2.17 ±0.25	40	
		0.75			2.04 ±0.25		
		1, 1.5, 4, 5, 5.5			1.84 ±0.25		
	2, 2.5, 6, 7, 8	1.54 ±0.25					
3	1.04 ±0.25						
9, 10	1.29 ±0.25						
1020	1, 1.5, 2, 2.5, 3	2.54	5.08±0.25	0.6	0.57 ±0.25	45	
2512	Green Underside	0.15	6.35	3.0 ±0.3	1.0	2.98 ±0.25	60
		0.2				2.88 ±0.25	
		0.25, 0.3				2.68 ±0.25	
		0.4				2.18 ±0.25	
		0.5				2.68 ±0.25	
		0.75	2.48 ±0.25				
		1, 5, 5.5, 6	3.0 ±0.2	0.6	1.93 ±0.25		
		2, 2.5, 3, 3.5, 8, 9, 10			1.18 ±0.25		
		4, 4.5			2.18 ±0.25		
		1.5, 6.5, 7, 7.5			1.43 ±0.25		
0.1, 0.2,	3.0	6.35±0.25			1	1.0±0.25	65
0.25, 0.3, 0.4			1	0.5±0.25			
0.5, 0.7, 0.75, 0.8, 0.9, 1.0			0.6	0.5±0.25			
1.5			0.6	1.0±0.25			
2			0.6	0.8±0.25			
2.5, 3			0.6	0.5±0.25			
2512	Black	0.5	6.35	3.18 ±0.25	1.3 ±0.38	1.4	60
		0.75, 2.5				1.0	
		1				0.8	
		1.5				0.65	
		2, 5, 6				0.5	
		3				0.7	
		3.5				0.71	
		4				0.6	
		4.5				0.58	
		5.5, 6.5				0.47	
		7				0.45	
10	0.8	1.9 ±0.15					

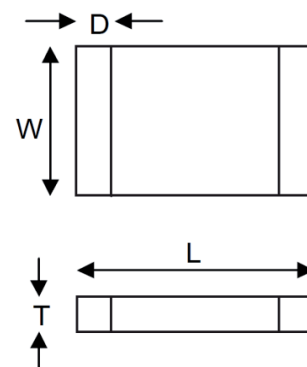

#### General Note

TT Electronics reserves the right to make changes in product specification without notice or liability.  
All information is subject to TT Electronics' own data and is considered accurate at time of going to print.

## ULR Series

### Construction

#### Black Coat

A low TCR resistance alloy plate, with tin plated connection bands is protectively coated on the upper and lower faces and numerically marked with the resistance value. This part is suitable for wave or reflow soldering.

#### Green Underside Coat

A low TCR resistance alloy plate is grooved to set the final resistance and the lower face only is protected with an epoxy coating. The lower faces are tin plated for connections. This part is ONLY suitable for reflow soldering.

#### Marking

Only black coated parts are marked. For values which are integer numbers of milliohms, the marking is 4-character IEC62 code; e.g. "R002" for 2mΩ, "R010" for 10mΩ. For values including fractions of a milliohm the marking is 3 or 4-character code using "M" to indicate the decimal point, e.g. "M75" for 0.75mΩ, "1M50" for 1.5mΩ.

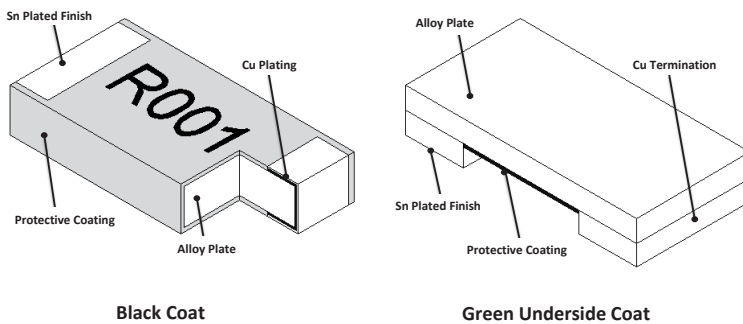

#### Termination Details:

**Material** Matt tin plated finish over copper.  
**Solderability** 95% min coverage (MIL-STD 202F / 208H, 235°C 2 secs)

### Power Derating Curve

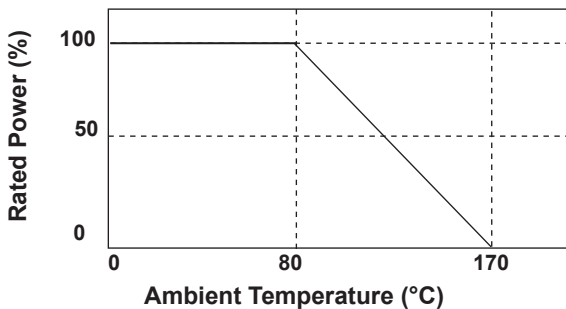

#### Notes

The power derating curve is a guidance based on a conservative design model. The ULR is a solid metal alloy construction that can withstand significantly greater operating temperatures than the conservative model permits. The protective coating will operate up to 260°C and the alloy can withstand in excess of 350°C. Therefore, the system thermal design will be a more significant design parameter due to the heat limitations of the solder joint.

#### General Note

TT Electronics reserves the right to make changes in product specification without notice or liability. All information is subject to TT Electronics' own data and is considered accurate at time of going to print.

## ULR Series

### Recommended Layouts and Measurement Probe Positions

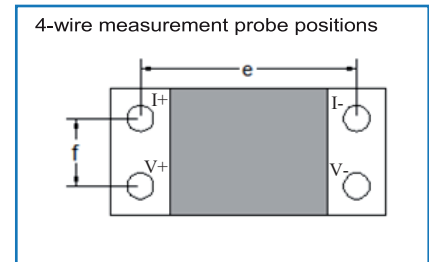
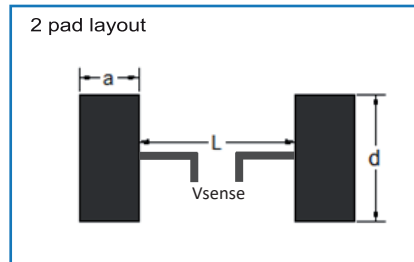
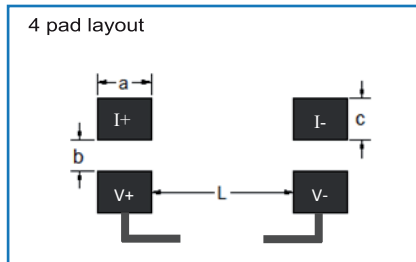

Size	Coating	Values	a	b	c	L	d	e	f	
1206	Green Underside	0.5, 0.6, 1, 4 - 6	1.55	0.5	0.7	0.55	1.9	2.6	1.25	
		2 - 3, 10	1.05			1.55				
		7 - 9	1.35			0.95				
2010		0.5	2.61	0.8	1.05	0.3	2.9	4.32	1.2	
		1, 4 - 5	2.29			0.95				
		2, 6 - 8	1.99			1.55				
		3	1.49			2.55				
		9 - 10	1.74			2.05				
1020		Black	1, 1.5, 2, 2.5, 3	0.925	0.8	2.365	1.04	5.53	2	1.77
2512			All	2.7	1.0	1.2	2.9	3.45	5.4	1.5
2512	0.5		3.13	0.54						
	0.75		2.93	0.94						
	1		2.38	2.04						
	1.5		1.88	3.04						
	2 - 3		1.63	3.54						
	4, 4.5		2.63	1.54						
	5 - 6		2.38	2.04						
	6.5, 7		1.88	3.04						
	8 - 10	1.63	3.54							
1225	0.1 - 0.25	1.4	0.8	3.0	0.6	6.8	2.0	2.25		
	0.3 - 1.0	0.9			1.6					
	1.5	1.4			0.6					
	2.0	1.2			1.0					
	2.5, 3.0	0.9			1.6					

### Symmetrical Kelvin Connected (4-Wire) Alternatives

Package	Resistance (mΩ)	a	b	c	d	e	f
1206	0.2 - 0.4	0.75	1.9	0.4	0.6	2.15	0.6
2010	0.2 - 0.4	1.35	2.89	1.4	0.6	3.08	0.6
2512 - Green Underside	0.15 - 0.3	2	3.4	1.0	0.6	2.8	0.6
	0.4	1.5	3.4	2.0	0.6	3.8	0.6

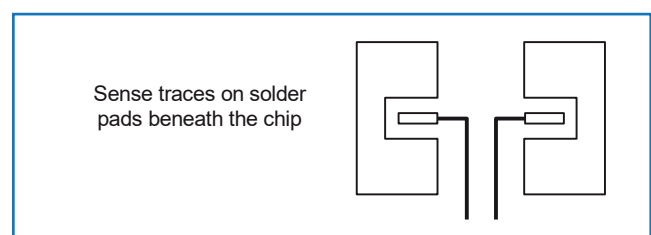
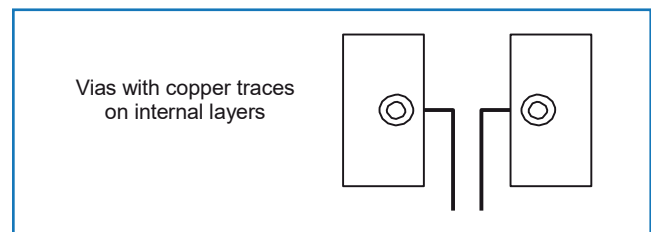
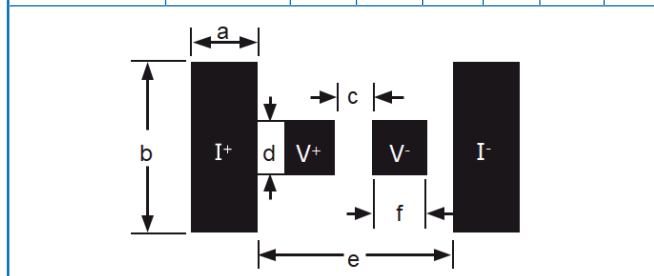

### General Note

TT Electronics reserves the right to make changes in product specification without notice or liability. All information is subject to TT Electronics' own data and is considered accurate at time of going to print.

## ULR Series

### Packaging

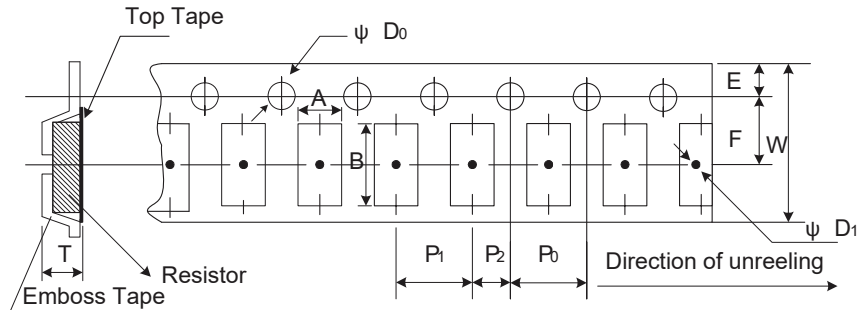

Type	Resistance (mΩ)	A	B	W	E	F	P0	P1	P2	ØD0	ØD1	T	Quantity (EA)
1206	<0.5	1.90 ± 0.1	3.60 ± 0.1	8.0 ± 0.2	1.75 ± 0.1	3.5 ± 0.05	4.0 ± 0.1	4.0 ± 0.1	2.0 ± 0.05	1.55 ± 0.05	1.0min	1.25 ± 0.1	2,000
	≥0.5											0.87 ± 0.1	
2010	<0.5	2.85 ± 0.1	5.55 ± 0.1	12.0 ± 0.2	1.75 ± 0.1	5.5 ± 0.05	4.0 ± 0.1	4.0 ± 0.1	2.0 ± 0.05	1.55 ± 0.05	1.5min	1.35 ± 0.1	2,000
	≥0.5											0.85 ± 0.1	
1020	1 - 3												
2512 Black	0.50 - 0.75	3.40 ± 0.1	6.75 ± 0.1	12.0 ± 0.1	1.75 ± 0.1	5.5 ± 0.05	4.0 ± 0.1	4.0 ± 0.1	2.0 ± 0.05	1.55 ± 0.05	1.4min	1.45 ± 0.2	2,000
	1.45 ± 0.2											0.81 ± 0.1	
2512 Green Underside	<0.5	3.40 ± 0.1	6.75 ± 0.1	12.0 ± 0.3	1.75 ± 0.1	5.5 ± 0.05	4.0 ± 0.1	4.0 ± 0.1	2.0 ± 0.05	1.55 ± 0.05	1.5min	1.4 ± 0.1	2,000
	≥0.5											0.8 ± 0.1	
1225	0.1 - 0.4	3.40 ± 0.1	6.75 ± 0.1	12.0 ± 0.3	1.75 ± 0.1	5.5 ± 0.05	4.0 ± 0.1	4.0 ± 0.1	2.0 ± 0.05	1.55 ± 0.05	1.5min	1.2 ± 0.1	2,000
	0.5-3.0											0.80 ± 0.1	

#### Note:

1. The cumulative tolerance of 10 sprocket hole pitch is ± 0.2 mm.
2. Carrier camber shall not be more than 1 mm per 100 mm through a length of 250 mm.
3. A & B measured 0.3 mm from the bottom of the packet.
4. T measured at a point on the inside bottom of the packet to the top surface of the carrier.
5. Pocket position relative to sprocket hole is measured as the true position of the pocket and not the pocket hole.

#### General Note

TT Electronics reserves the right to make changes in product specification without notice or liability. All information is subject to TT Electronics' own data and is considered accurate at time of going to print.

## ULR Series

### Ordering Procedure

This product has two valid part numbers:

**European (Welwyn) Part Number: ULR2-R0015FT2** (2512, 1.5 milliohms  $\pm 1\%$ , Pb-free)

U	L	R	2	-	R	0	0	1	5	F	T	2
1			2				3	4				

1 Type	2 Value	3 Tolerance	4 Packing
ULR1S, ULR1, ULR15S, ULR2N, ULR2, ULR25, ULR3, ULR3N	3 to 6 characters R = ohms	F = $\pm 1\%$ J = $\pm 5\%$	T2 = Plastic tape All sizes   2000/reel

**USA (IRC) Part Number: ULRB22512R0015FLFSLT** (2512, 1.5 milliohms  $\pm 1\%$ , Pb-free)

U	L	R	B	2	2	5	1	2	R	0	0	1	5	F	L	F	S	L	T
1			2			3			4	5	6								

1 Type	2 Size	3 Value	4 Tolerance	5 Termination	6 Packing
ULRG1, ULRG15, ULRG2, ULRG25, ULRG3, ULRB1, ULRB2	1206 2010 2512	4 - 6 characters R = ohms	F = $\pm 1\%$ J = $\pm 5\%$	LF = Pb-free	SLT = Plastic tape All sizes   2000/reel

#### General Note

TT Electronics reserves the right to make changes in product specification without notice or liability. All information is subject to TT Electronics' own data and is considered accurate at time of going to print.