

Caussade, 09th January 2026

APEM ref. 2026010901

PRODUCT END OF LIFE – ATEX PBA

APEM hereby announces the discontinuation of sales for the PBA ATEX series. All products listed below are being phased out.

APEM will accept a Last Time Buy with final orders placed by the end of July 2026, and the corresponding production batch completed no later than October 12th, 2026.

Product List of discontinued products (non-exhaustive) :

PBAR1AFB000A0BX
PBAR1AFB000A0GX
PBAR1AFB000A0SX
PBAR1AFB000MX
PBAR2AFB000LOGX
PBAR2AFB000LOSX
PBAR2AFB000LOYX
PBAR2AFB000MX
PBAR2AFB038LOGX
PBAR9AFB000A0BX
PBAR9AFB000A0GX
PBAR9AFB000A0SX
PBAR9AFB000A0YX
PBAR9AFB000MX

Vivien Rineau – Product Marketing Manager



PBA series

ATEX approved piezo switches



DISTINCTIVE FEATURES

Approved according to the ATEX 2014/34/EU directive

Sealed to IP66 (mounted on panel)

Easy to clean metal surface

Long life

Illuminated models



ENVIRONMENTAL SPECIFICATIONS

- Sealing : IP66 per IEC 60529 (switches mounted on panel)
- Operating temperature : -40 °C to +55 °C (-40 °F to +131 °F)
- Extreme thermal shock may briefly trigger the switch



ELECTRICAL SPECIFICATIONS

- Rated voltage : 5 V to 24 VAC/DC max.
- Rated current : 200 mA max. at 6 VAC/DC
50 mA max. at 24 VAC/DC (power limited to 1.2 W for user group II)
- Contact resistance (ON) : 10 Ω max.
- Insulation resistance (OFF) : 5 MΩ min.
- Make impulse time : depending on actuating force and speed
- LED : 5 VDC, 10 mA to 20 mA depending on model



GENERAL SPECIFICATIONS

- Operating force : 2 to 6 N
- Torque : 2.5 Nm max.
- Life expectancy : 50 million cycles
- EMC compatibility according to EN 61058-1
- In accordance with EN 60079:2009* ; EN 60079-26:2007 ; EN 60079-11:2012 ; EN 50303:2000

*Changes to the latest standards EN60079-0 :2018 and EN60079-26 :2015 do not affect compliance with the essential requirements.

The company reserves the right to change specifications without notice.



PBA series

ATEX approved piezo switches



MATERIALS

- Case : 316L stainless steel
- Terminals : multi-wire leads
0.22 mm², length 300 mm (11.81)

APEM products may be recycled at end-of-life for the re-claiming of valuable metal components.

AGENCY APPROVAL



II 1 G D ; I M1

Ex ia IIC T4 Ga ; Ex ia I Ma
Ex ia IIIC T135°C Da IP66

Usage : mines full of fire damp and potentially explosive atmospheres of groups IIC, IIB et IIA in T4 temperature class and/or in the presence of combustible dust (T135°C).

PBA series

ATEX approved piezo switches



BUILD YOUR PART NUMBER

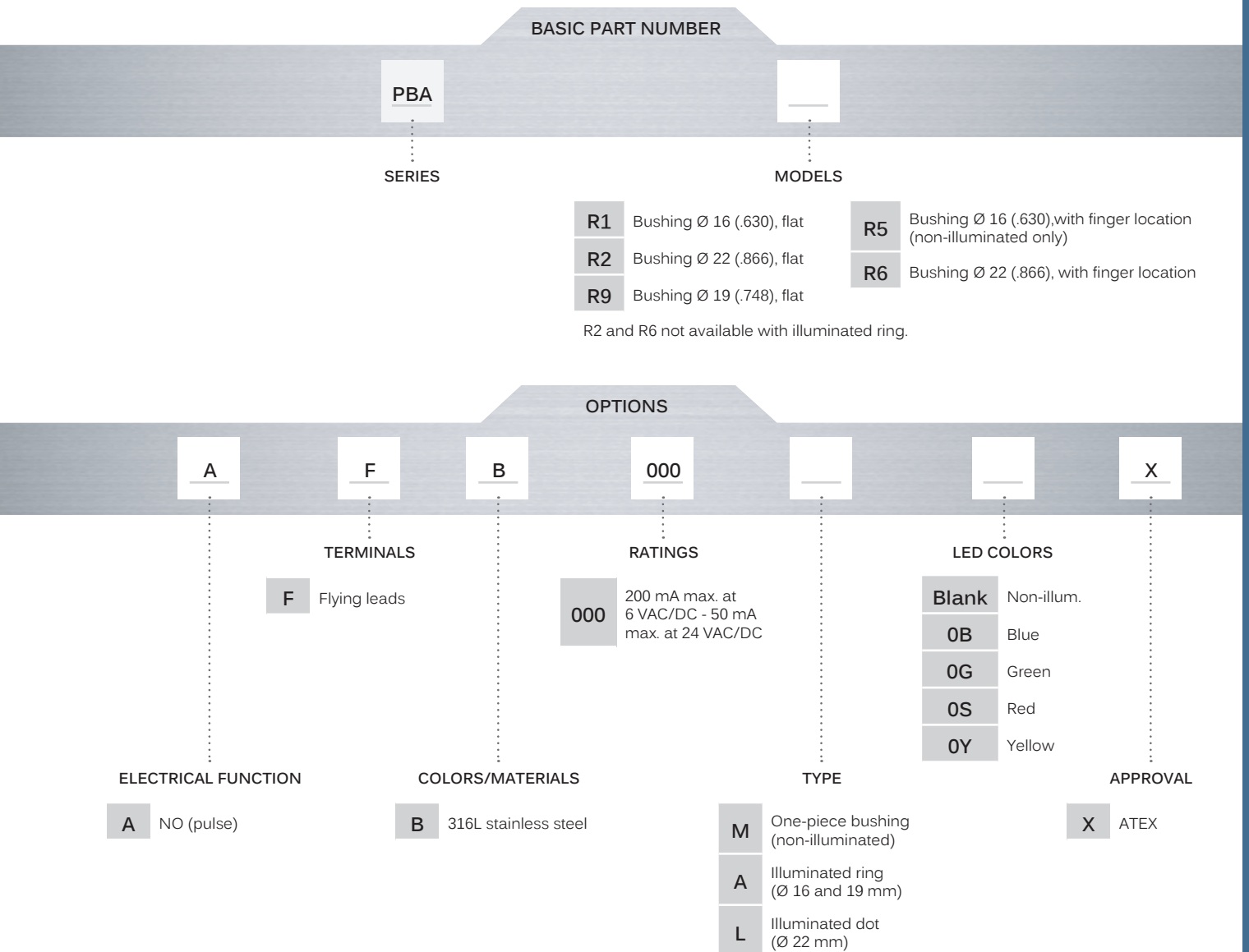

ABOUT THIS SERIES



Instructions for use : see instruction notice NTPBA007.



Mounting accessories : Standard hardware supplied : 1 hex nut 10-621 (19 mm ac. flats), 10-855-0 (22 mm ac. flats) or 10-856-0 (25 mm ac. flats), 1 O-Ring and 1 ground connector

PBA series

ATEX approved piezo switches

Ø16 (.630) BUSHING - NON-ILLUMINATED



PBAR1AFB000MX

PBAR5AFB000MX

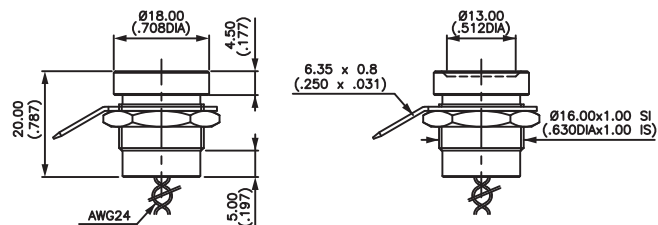

R1

R5

Ø16 (.630) BUSHING - WITH ILLUMINATED RING



PBAR1AFB000A•X

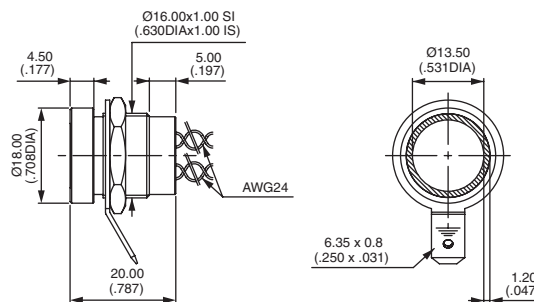

Ø19 (.748) BUSHING - NON-ILLUMINATED



PBAR9AFB000MX

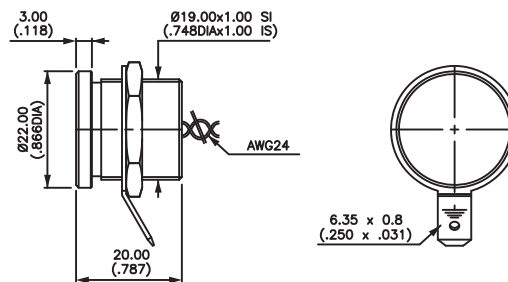

Ø19 (.748) BUSHING - WITH ILLUMINATED RING



PBAR9AFB000AX

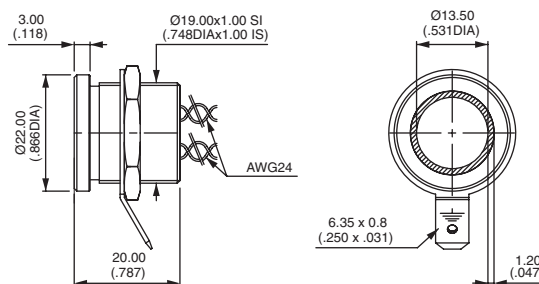

PBA series

ATEX approved piezo switches

Ø22 (.866) BUSHING - NON-ILLUMINATED



PBAR2AFB000MX

PBAR6AFB000MX

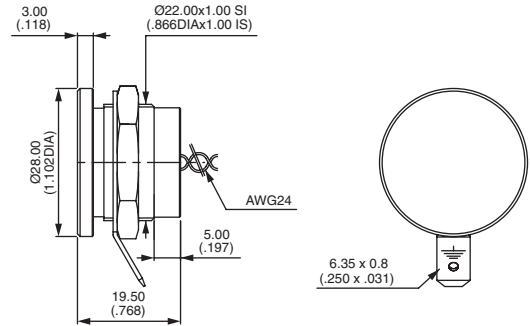

Ø22 (.866) BUSHING - WITH ILLUMINATED DOT



PBAR2AFB000L•X

PBAR6AFB000L•X

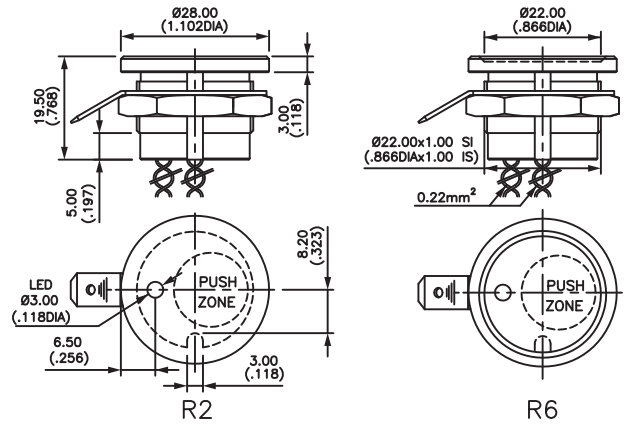

To order a product, replace • by the LED color code below :

- 0B Blue
- 0G Green
- 0S Red
- 0Y Yellow



**DECLARATION UE DE CONFORMITE
EU DECLARATION OF CONFORMITY**

Nous Société APEM SA
We BP1 82300 CAUSSADE

Déclarons sous notre seule responsabilité que les produits suivants :
Declare under our sole responsibility that the following products :

Références / Part numbers

Interrupteurs pour appareils
Switches for appliances

PBA.AF.000...X

Satisfont aux dispositions de la Directive Européenne
satisfy the dispositions of Directive Concl

2014/34/UE
2014/34/EU

Références des normes harmonisées pertinentes appliquées ou des autres spécifications techniques par rapport auxquelles la conformité est déclarée
References to the relevant harmonised standards used or references to the other technical specifications in relation to which conformity is declared::

EN60079-0:2009 + EN60079-26:2007 + EN60079-11:2012 + EN50303:2000

Number of EC-Type-examination : INERIS 07ATEX0043X/02

Number of Production Quality Assurance Notification : INERIS 08ATEXQ408 issue 04

Notified body : INERIS Parc Technologique Alata BP2 – F60050 Verneuil-en_Halatte
Identification number : 0080

Additional information :

Les modifications des dernières normes en vigueur EN IEC 60079-0:2018 et EN60079-26:2015 n'impactent pas la conformité aux exigences essentielles
Changes to the latest standards EN IEC 60079-0: 2018 and EN60079-26:2015 do not affect compliance with the essential requirements

CAUSSADE, le 16 Octobre/October 2020

Signature

Marc ENJALBERT
Directeur général

1/ MARQUAGE COMPLET :

APEM
BP1 - 55 avenue Edouard Herriot – 82303 CAUSSADEI
PBA.AF...X

 0080 (n° de l'organisme ayant en charge le contrôle de la fabrication)
Code date (année/semaine, ex. 09/03)

 II 1 G D ; I M1
Ex ia IIC T4 Ga ; Ex ia I Ma
Ex ia IIIC T135°C Da IP66

2/ MARQUAGE REDUIT :

APEM PBA..AF.....X Exi INERIS 07ATEX0043X

3/ INSTRUCTIONS DE FORMATION :

 Tout montage ou toute intervention sur le matériel doit être effectué par des personnes ayant reçu une formation ATEX.

4/ MONTAGE (sur panneau) : Couple de serrage maxi : 2.5 Nm

Version canon Ø16 :
Perçage Ø16.2mm (.637), montage avec écrou hexagonal 10-621, rondelle de mise à la terre U5735 et joint torique 10-1155. Serrage avec clé dynamométrique de 19 mm sur plats.

Version canon Ø19 :
Perçage Ø19.2mm (.755), montage avec écrou hexagonal 10-855-5, rondelle de mise à la terre U5736 et joint torique U1961. Serrage avec clé dynamométrique de 22 mm sur plats.

Version canon Ø22 :
Perçage Ø22.2mm (.874), montage avec écrou hexagonal 10-856-5, rondelle de mise à la terre U5737 et joint torique U1961. Serrage avec clé dynamométrique de 25 mm sur plats.

Autres versions de canon : Utiliser le plan et les accessoires spécifiques fournis.

5/ DEMONTAGE : effectuer les opérations inverses du montage.**6/ RACCORDEMENT (à effectuer hors tension) :**

Un dossier descriptif système doit être établi.

 L'équipement raccordé à ce matériel sera certifié en sécurité intrinsèque pour le groupe ATEX correspondant à son utilisation suivant les caractéristiques d'entrée indiquées ci-après.

Sur les fils rouges (partie détection des appuis) :
- Groupe I : $U_i = 24V$ AC ou DC, $I_i = 400$ mA ; $P_i = 3.15W$; $C_i = 4.3$ nF ; $L_i = 0$ µH
- Groupe II : $U_i = 24V$ AC ou DC, $I_i = 400$ mA ; $P_i = 1.2W$; $C_i = 4.3$ nF ; $L_i = 0$ µH

Sur les fil jaunes (+VLED) par rapport au fil bleu (GROUND) (partie éclairage) :
- Groupe I : $U_i = 24V$ AC ou DC, $I_i = 400$ mA ; $P_i = 3.15W$; $C_i = 0$ nF ; $L_i = 0$ µH
- Groupe II : $U_i = 24V$ AC ou DC, $I_i = 400$ mA ; $P_i = 1.2W$; $C_i = 0$ nF ; $L_i = 0$ µH

Le matériel doit être relié à la terre par la rondelle prévue à cet effet et la longueur des fils entre l'interrupteur et la partie commandée ne doit pas dépasser 10m, ceci pour assurer une compatibilité électromagnétique suivant la norme EN61058-1.

7/ REGLAGE : ce matériel ne nécessite pas de réglage.**8/ MISE EN SERVICE :**

La mise en service est effectuée après approbation du maître d'œuvre ou du responsable du site sur la base du rapport de l'installateur et de toute personne habilitée à vérifier la conformité des installations ATEX.

9/ UTILISATION :

 Mines grisouteuses en catégories M2 et M1, atmosphères explosives gazeuses des groupes IIC, IIB et IIA en zones 0, 1, 2 (classe de température T4) et/ou atmosphères poussiéreuses combustibles (T135°C) en zones 20, 21 et 22.

10/ CONDITIONS PARTICULIERES D'UTILISATION :

Plage de température de -40 à +55°C

 **Les sources connectées à ce matériel doivent être des sources certifiées en sécurité intrinsèque pour le groupe ATEX correspondant à l'utilisation du matériel. Les caractéristiques de sortie de ces sources doivent être compatibles avec les caractéristiques d'entrée indiquées au paragraphe 6.**

11/ MAINTENANCE : en cas de panne ou de mauvaise utilisation, le matériel doit être remplacé.**12/ CARACTERISTIQUES ELECTRIQUES :**

- * Tension commutée : 5V à 24Vca/cc maxi
- * Intensité commutée : 0.2A maxi
- * Durée de l'impulsion : dépend de la force et de la rapidité d'appui.
- * Résistance d'isolement (OFF) : 5MΩ mini
- * Résistance de contact (ON) : 10Ω maxi

13/ CARACTERISTIQUES MECANIQUES :

- * Corps en acier inoxydable ou en laiton.
- * Sorties à fils multibrins AWG24 longueur 300 mm (11.81)
- * Force de manœuvre : 2 à 6N
- * Etanchéité IP66 selon CEI 60529 (interrupteurs montés sur panneau)

14/ CONFORMITE ATEX :

- * Directive 2014/34/UE
- * Normes : EN60079-0:2009, EN60079-11 :2012, EN60079-26 :2007, EN50303 :2000.

Les modifications des dernières normes en vigueur EN IEC 60079-0:2018 et EN60079-26:2015 n'impactent pas la conformité aux exigences essentielles

15/ ADRESSE DU FABRICANT :

APEM 55 avenue Edouard Herriot BP1 82303 CAUSSADE Cedex (France)
Tél : +33 5 63 93 14 98 Fax : +33 5 63 93 19 03

1/ MARCADO COMPLETO:

APEM
BP1 - 55 avenue Edouard Herriot – 82303 CAUSSADE, Francia
PBA.AF...X

 0080 (N° del organismo responsable del control de la fabricación)
Código fecha (año/semana, ej. 09/03)

 II 1 G D; I M1
Ex ia IIC T4 Ga; Ex ia I Ma
Ex ia IIIC T135°C Da IP66

2/ MARCADO REDUCIDO:

APEM PBA..AF.....X Exi INERIS 07ATEX0043X

3/ INSTRUCCIONES DE FORMACIÓN:

 Cualquier montaje o cualquier intervención en el material deben ser realizados por personas que hayan tenido una formación ATEX.

4/ MONTAJE (en panel): Par de apriete máximo: 2,5 Nm

. Versión canon Ø 16:
Taladro Ø 16,2 mm (.637), montaje con tuerca hexagonal 10-621, arandela de puesta a tierra U5735 y junta tórica 10-1155. Apriete con llave dinamométrica de 19 mm en plano.

. Versión canon Ø 19:
Taladro Ø 19,2 mm (.755), montaje con tuerca hexagonal 10-855-5, arandela de puesta a tierra U5736 y junta tórica U1961. Apriete con llave dinamométrica de 22 mm en plano.

. Versión canon Ø 22:
Taladro Ø 22,2 mm (.874), montaje con tuerca hexagonal 10-856-5, arandela de puesta a tierra U5737 y junta tórica U1961. Apriete con llave dinamométrica de 25 mm en plano.

. Otras versiones de canon: Utilizar el plano y los accesorios específicos suministrados.

5/ DESMONTAJE: realizar las operaciones inversas al montaje.**6/ CONEXIONADO** (realizar fuera de tensión):**Debe ser elaborado un dossier descriptivo del sistema.**

 El equipo conectado a este material será certificado en seguridad intrínseca para el grupo ATEX correspondiente a su utilización según las características de entrada indicadas a continuación.

En los cables rojos (parte de detección de los apoyos):

- Grupo I: $U_i = 24V$ AC o DC, $I_i = 400$ mA; $P_i = 3,15$ W; $C_i = 4.3$ nF; $L_i = 0$ μ H

- Grupo II: $U_i = 24V$ AC o DC, $I_i = 400$ mA; $P_i = 1,2$ W; $C_i = 4.3$ nF; $L_i = 0$ μ H

En los cables amarillos (+VLED) en relación con el cable azul (GROUND) (parte alumbrado):

- Grupo I: $U_i = 24V$ AC o DC, $I_i = 400$ mA; $P_i = 3,15$ W; $C_i = 0$ nF; $L_i = 0$ μ H

- Grupo II: $U_i = 24V$ AC o DC, $I_i = 400$ mA; $P_i = 1,2$ W; $C_i = 0$ nF; $L_i = 0$ μ H

El material debe ser conectado a tierra por medio de la arandela prevista al efecto y la longitud de los cables entre el interruptor y la parte controlada no debe sobrepasar 10 metros, para asegurar una compatibilidad electromagnética según la norma EN61058-1.

7/ AJUSTE: este material no necesita ningún ajuste.

8/ PUESTA EN SERVICIO:

La puesta en servicio se realiza después de la aprobación del director de obra o del responsable del lugar sobre la base del informe del instalador y de cualquier otra persona habilitada para comprobar la conformidad de las instalaciones ATEX.

9/ UTILIZACIÓN:

 Minus de grisú en categorías M2 y M1, atmósferas explosivas de gas de los grupos IIC, IIB y IIA en zonas 0, 1, 2 (clase de temperatura T4) y/o atmósferas de polvo combustible (T135°C) en zonas 20, 21 y 22.

10/ CONDICIONES PARTICULARES DE UTILIZACIÓN:

Franja de temperatura -40 a +55 °C

 **Las fuentes conectadas a este material deben ser fuentes certificadas en seguridad intrínseca para el grupo ATEX correspondiente a la utilización del material. Las características de salida de estas fuentes deben ser compatibles con las características de entrada indicadas en el párrafo 6.**

11/ MANTENIMIENTO: en caso de avería o de mala utilización, el material debe ser reemplazado.

12/ CARACTERÍSTICAS ELÉCTRICAS:

- * Tensión conmutada: 5V a 24V ca/cc máximo
- * Intensidad conmutada: 0,2 A máximo
- * Duración del impulso: depende de la fuerza y de la rapidez de apoyo.
- * Resistencia al aislamiento (OFF): 5 M Ω mínimo
- * Resistencia de contacto (ON): 10 Ω máximo

13/ CARACTERÍSTICAS MECÁNICAS:

- * Cuerpo de acero inoxidable o de latón.
- * Salidas de los cables multihilos AWG24 longitud 300 mm (11.81)
- * Fuerza de maniobra: 2 a 6 N
- * Estanqueidad IP66 según CEI 60529 (interruptores montados en panel)

14/ CONFORMIDAD ATEX:

- * Directiva 2014/34/UE
- * Normas: EN60079-0:2009, EN60079-11: 2012, EN60079-26: 2007, EN50303: 2000.

Los cambios en las últimas normas EN IEC 60079-0:2018 y EN60079-26:2015 no afectan al cumplimiento de los requisitos esenciales.

15/ DIRECCIÓN DEL FABRICANTE:

APEM 55 avenue Edouard Herriot BP1 82303 CAUSSADE Cedex (Francia)

Tel.: +33 5 63 93 14 98 Fax: +33 5 63 93 19 03

1/ COMPLETE MARKING

APEM
BP1 – 55 avenue Edouard Herriot – 82303 CAUSSADE
PBA.AF.000...X

 0080 (No of notified body in charge of production control)
Date code (year/week, ex. 09/03)

 II 1 G D ; I M1
Ex ia IIC T4 Ga ; Ex ia 1 Ma
Ex ia IIIC T135°C Da IP66

2/ REDUCED MARKING

APEM PBA..AF...X Exi INERIS 07ATEX0043X

3/ INSTRUCTIONS FOR USE

 Mounting and other interventions on these switches shall be carried out by ATEX-trained personnel.

4/ PANEL MOUNTING Max. torque : 2,5 Nm

- Ø16 mm bushing version:
Ø16,2 mm (.637) cut-out, with hex nut 10-621,
ground connector U5735 and O-ring 10-1155 supplied with the switch.
Fastening with a dynamometric wrench of 19 mm across flats.
- Ø19 mm bushing version:
Ø19,2 mm (.755) cut-out, with hex nut 10-855-5,
ground connector U5736 and O-ring U1961 supplied with the switch.
Fastening with a dynamometric wrench of 22 mm across flats.
- Ø22 mm bushing version:
Ø22,2 mm cut-out (.874), with hex nut 10-856-5,
ground connector U5737 and O-ring U1961 supplied with the switch.
Fastening with a dynamometric wrench of 25 mm across flats.
- Other bushing versions: use specific drawing and accessories supplied

5/ DISASSEMBLY : reversed operation as assembly.

6/ CONNECTION (switch unpowered)

 The equipment connected to the switches is certified intrinsically safe for the ATEX group corresponding to the use of the switches according to the input specifications mentioned hereafter.

On red wires (detection part of supports)

- Group I : $U_i = 24V$ AC or DC ; $I_i = 400$ mA ; $P_i = 3,15$ W ; $C_i = 4,3$ nF ; $L_i = 0$ μ H
- Group II : $U_i = 24V$ AC or DC ; $I_i = 400$ mA ; $P_i = 1,2$ W ; $C_i = 4,3$ nF ; $L_i = 0$ μ H

On the yellow wire (+VLED) compared to blue wire (GROUND) (lighting part)

- Group I : $U_i = 24V$ AC or DC ; $I_i = 400$ mA ; $P_i = 3,15$ W ; $C_i = 0$ nF ; $L_i = 0$ μ H
- Group II : $U_i = 24V$ AC or DC ; $I_i = 400$ mA ; $P_i = 1,2$ W ; $C_i = 0$ nF ; $L_i = 0$ μ H

The switches shall be connected to ground with the appropriate ground connector and wire length between switch and operated part shall not exceed 10m. This will ensure EMC according to the EN61058-1 standard.

7/ ADJUSTMENT : the switches do not require any adjustment

8/ BRINGING INTO SERVICE

Bringing into service will be made after approval by the project manager, on the base of the reports issued by the installation engineer or any person entitled to verify the conformity of ATEX installations.

9/ USAGE

 Mines full of damp classified M2 and M1, potentially explosive atmospheres of groups IIC and IIA in areas 0. 1. 2 (T4 temperature class and/or in the presence of combustible dust (T135°C) in areas 20. 21. 22.

10/ SPECIFIC USAGE CONDITIONS Temperature range from -40°C to +55°C

 The equipment connected to the switches should be certified intrinsically safe for the ATEX group corresponding to the use of the switches. The output specifications of the equipment should be compatible with the input specs mentioned in paragraph 6.

11/ MAINTENANCE : in case of failure or wrong usage, the switches shall be replaced.

12/ ELECTRICAL SPECIFICATIONS

- Rated voltage: 5V to 24VAC/DC max.
- Rated current: 0,2A max.
- Make impulse time: depending on actuation force and speed
- Insulation resistance (OFF): 5 M Ω mini.
- Contact resistance (ON): 10 Ω max.

13/ MECHANICAL SPECIFICATIONS

- Case: stainless steel or brass
- Multiwire flying lead terminals AWG24, length 300 mm (11.81)
- Operating force: 2 to 6N
- Sealing: IP66 per IEC60529 (switches mounted on panel)

14/ ATEX CONFORMITY

- ATEX directive 2014/34/UE
- Conformity to standards: EN60079-0:2009, EN60079-11 :2012, EN60079-26 :2007, EN50303 :2000
Changes to the latest standards EN IEC 60079-0: 2018 and EN60079-26:2015 do not affect compliance with the essential requirements

15/ MANUFACTURER ADDRESS

APEM 55 avenue Edouard Herriot BP1 82303 CAUSSADE Cedex (France)
Phone : +33 5 63 93 14 98 - Fax : +33 5 63 93 19 03

1/ KENNZEICHNUNG (vollständig)

APEM
BP1 – 55 avenue Edouard Herriot – 82303 CAUSSADE
PBA.AF.000...X

 0080 (Nummer der Benannten Stelle)
Datums-Code (Jahr/Woche, z.B. 17/03)

 II 1 G D ; I M1
Ex ia IIC T4 Ga ; Ex ia 1 Ma
Ex ia IIIC T135°C Da IP66

2/ KENNZEICHNUNG (vereinfacht)

APEM PBA..AF...X Exi INERIS 07ATEX0043X

3/ BETRIEBSANWEISUNG

 Die Montage und weitere Eingriffe den Schalter betreffend sollten nur von ATEX-geschulten Personen durchgeführt werden.

4/ FRONTPLATTEMONTAGE Max. Drehmoment: 2,5Nm

- Ø16mm Variante:
Ø16,2mm (.637) Frontplattenausschnitt, wird zusammen mit Sechskantmutter 10-621, Erdungsring U5735 und O-Ring 10-1155 ausgeliefert
Festzuziehen mit Drehmomentschlüssel, Schlüsselweite 19
- Ø19mm Variante:
Ø19,2mm (.755) Frontplattenausschnitt, wird zusammen mit Sechskantmutter 10-855-5, Erdungsring U5735 und O-Ring U1961 ausgeliefert
Festzuziehen mit Drehmomentschlüssel, Schlüsselweite 22
- Ø22mm Variante:
Ø22,2mm (.874) Frontplattenausschnitt, wird zusammen mit Sechskantmutter 10-856-5, Erdungsring U5735 und O-Ring U1961 ausgeliefert
Festzuziehen mit Drehmomentschlüssel, Schlüsselweite 25
- Andere Gehäusevarianten: Bitte verwenden Sie das mitgelieferte Zubehör und orientieren sich an der spezifischen Zeichnung

5/ DEMONTAGE: umgekehrt zum Montagevorgang

6/ ANSCHLUSS (Schalter nicht angeschlossen)

 Die an die Schalter angeschlossene Ausrüstung ist als, für die ATEX-Gruppe eigensicher zertifiziert, entsprechend des Verwendungszwecks der Schalter und der nachfolgend angeführten Eingangswerte.

An roten Litzen
- Gruppe I : $U_i = 24V$ AC oder DC ; $I_i = 400mA$; $P_i = 3,15W$; $C_i = 4,3nF$; $L_i = 0\mu H$
- Gruppe II : $U_i = 24V$ AC oder DC ; $I_i = 400mA$; $P_i = 1,2W$; $C_i = 4,3nF$; $L_i = 0\mu H$

An der gelben Litzen (+VLED) im Vergleich zur blauen Litze (Masse) (Beleuchtung)

- Gruppe I : $U_i = 24V$ AC oder DC ; $I_i = 400mA$; $P_i = 3,15W$; $C_i = 0nF$; $L_i = 0\mu H$
- Gruppe II : $U_i = 24V$ AC oder DC ; $I_i = 400mA$; $P_i = 1,2W$; $C_i = 0nF$; $L_i = 0\mu H$

Die Schalter sollten mit einem geeigneten Anschluss geerdet werden und die Leiterlänge zwischen dem Schalter und der angesteuerten Einheit sollte nicht mehr als 10m betragen. Dies gewährleistet eine EMV Gemäß der Norm EN61058-1.

7/ JUSTIERUNG: Der Schalter benötigt keinerlei Justierung

8/ INBETRIEBNAHME

Die Inbetriebnahme wird nach Zustimmung des Projektmanagers und auf Basis des Berichts des Inbetriebnahme-Ingenieurs oder jeder anderen, zur ATEX konformen Inbetriebnahme befugten Person durchgeführt.

9/ EINSATZ

 Minen mit hoher Luftfeuchtigkeit M2 und M1 klassifiziert, möglicherweise explosionsgefährdete Umgebungen der Gruppen IIC und IIA in Bereichen 0. 1. 2 (T4 Klasse und/oder in Umgebung von entflammbarem Staub (T135°C) in Bereichen 20. 21. 22.)

10/ SPEZIFISCHE EINSATZBEDINGUNGEN Temperaturbereiche von -40°C bis +55°C

 Die an die Schalter angeschlossene Ausrüstung ist als, für die ATEX-Gruppe eigensicher zertifiziert, entsprechend des Verwendungszwecks der Schalter. Die Spezifikationen der Ausgangswerte sollte zu denen der unter Paragraph 6 erwähnten Eingangswerte kompatibel sein.

11/ INSTANDHALTUNG: Im Fehlerfall oder bei nicht ordnungsgemäßer Nutzung sollten die Schalter ersetzt werden.

12/ ELECTRISCHE SPEZIFIKATIONEN

- Nennspannung: 5V bis 24VAC/DC max.
- Nennstrom: 0,2A max.
- Schaltimpulsdauer: abhängig von der Betätigungskraft und -geschwindigkeit
- Isolationswiderstand (AUS): $5M\Omega$ min.
- Kontaktwiderstand (AN): 10Ω max.

13/ MECHANISCHE SPEZIFIKATIONEN

- Gehäuse: Edelstahl oder Messing
- Mehradrige Litzen AWG24, Länge 300 mm (11.81)
- Betätigungskraft: 2N bis 6N
- Abdichtung: IP66 nach IEC60529 (bei Frontplattenmontage)

14/ ATEX Konformität

- ATEX Richtlinie 2014/34/EU
- Konform mit den Normen: EN60079-0:2009, EN60079-11:2012, EN60079-26:2007, EN50303:2000
Änderungen der neuesten Normen EN IEC 60079-0:2018 und EN60079-26:2015 haben keinen Einfluss auf die Einhaltung der grundlegenden Anforderungen

15/ HERSTELLER ADRESSE

APEM 55 avenue Edouard Herriot BP1 82303 CAUSSADE Cedex (Frankreich)
Tel. : +33 5 63 93 14 98 - Fax : +33 5 63 93 19 03

1/ CODIFICA COMPLETA

APEM
BP1 – 55 avenue Edouard Herriot – 82303 CAUSSADE
PBA.AF.000...X

 0080 (riferimento di controllo produzione)
Codice data (anno/settimana, ex. 09/03)

 II 1 G D ; I M1
Ex ia IIC T4 Ga ; Ex ia 1 Ma
Ex ia IIIC T135°C Da IP66

2/ CODIFICA RIDOTTA

APEM PBA..AF...X Exi INERIS 07ATEX0043X

3/ ISTRUZIONI D'USO

 L'assemblaggio ed altri interventi su questi pulsanti dovranno essere effettuati da personale qualificato ATEX.

4/ MONTAGGIO A PANNELLO Max. torque : 2,5 Nm

- modello con corpo da Ø16 mm:
foro pannello Ø16,2 mm (.637), con dado esagonale 10-621,
anello di messa a terra U5735 e O-ring 10-1155 forniti con il pulsante.
Serraggio a mezzo di chiave dinamometrica di 19 mm sulle aree piatte.

- modello con corpo da Ø19 mm:
foro pannello Ø19,2 mm (.755) con dado esagonale 10-855-5,
anello di messa a terra U5736 e O-ring U1961 forniti con il pulsante.
Serraggio a mezzo di chiave dinamometrica di 22 mm sulle aree piatte.

- modello con corpo da Ø22 mm:
foro pannello Ø22,2 mm (.874), con dado esagonale 10-856-5,
anello di messa a terra U5737 e O-ring U1961 forniti con il pulsante.
Serraggio a mezzo di chiave dinamometrica di 25 mm sulle aree piatte.

- per altre versioni di corpo utilizzare i riferimenti su disegni specifici e gli accessori forniti.

5/SMONTAGGIO effettuare l'operazione inversa al montaggio.

6/ CONNESSIONE (pulsante non alimentato)

 L'unità connessa allo switch è intrinsecamente certificato sicuro dal corrispondente gruppo ATEX, in accordo alle specifiche di alimentazione riportate qui di seguito.

Filo rosso (contatti del pulsante)

- Gruppo I : $U_i = 24V$ AC or DC ; $L_i = 400$ mA ; $P_i = 3,15$ W ; $C_i = 4,3$ nF ; $L_i = 0$ μ H
- Gruppo II : $U_i = 24V$ AC or DC ; $L_i = 400$ mA ; $P_i = 1,2$ W ; $C_i = 4,3$ nF ; $L_i = 0$ μ H

Filo giallo (+VLED) contrapposto al filo blu (GROUND) (parte illuminata)

- Gruppo I : $U_i = 24V$ AC or DC ; $L_i = 400$ mA ; $P_i = 3,15$ W ; $C_i = 0$ nF ; $L_i = 0$ μ H
- Gruppo II : $U_i = 24V$ AC or DC ; $L_i = 400$ mA ; $P_i = 1,2$ W ; $C_i = 0$ nF ; $L_i = 0$ μ H

I pulsanti dovranno essere collegati alla messa a terra per mezzo del connettore appropriato e la lunghezza del filo non dovrà eccedere i 10mm. Questo assicurerà l'EMC in accordo con gli standard EN61058-1.

7/ CONFIGURAZIONE I pulsanti non necessitano di alcuna modifica o configurazione

8/ MESSA IN FUNZIONE

La messa in funzione dovrà essere effettuata dopo l'approvazione del Project Manager, sulla base dei report redatti da coloro che sono preposti a verificare la conformità ATEX.

9/ UTILIZZO

 Miniere con umidità classificate M2 e M1, atmosfere potenzialmente esplosive nei gruppi IIC e IIA in aree 0. 1. 2 (classe di temperature T4 e/o in presenza di polvere combustibile (T135°C) in aree 20. 21. 22.

10/ CONDIZIONI DI UTILIZZO SPECIFICHE

 range di temperatura da -40°C a +55°C
L'unità connessa allo switch è intrinsecamente certificato sicuro dal corrispondente gruppo ATEX, in accordo alle specifiche di alimentazione riportate al paragrafo 6

11/ MANUTENZIONE : in caso di malfunzionamento o errore di utilizzo, sostituire il pulsante.

12/ SPECIFICHE ELETTRICHE

- * Voltaggio: 5V to 24VAC/DC max.
- * Corrente: 0,2A max.
- * Durata impulso: dipende dalla forza e dalla velocità di attuazione
- * Resistenza di isolamento (OFF): 5 M Ω mini.
- * Resistenza di contatto (ON): 10 Ω max.

13/ SPECIFICHE MECCANICHE

- * Corpo: acciaio inox o ottone
- * Terminali a fili liberi AWG24, lunghezza 300 mm (11.81)
- * Forza di attuazione: 2 to 6N
- * Sealing: IP66 per IEC60529 (pulsante montato a pannello)

14/ CONFORMITA' ATEX

- Direttiva ATEX 2014/34/UE
- Conformità agli standard: EN60079-0:2009, EN60079-11 :2012, EN60079-26 :2007, EN50303 :2000

Le modifiche alle norme più recenti EN IEC 60079-0:2018 e EN60079-26:2015 non influiscono sulla conformità ai requisiti essenziali

15/ INDIRIZZO DEL PRODUTTORE

APEM 55 avenue Edouard Herriot BP1 82303 CAUSSADE Cedex (Francia)
Telefono : +33 5 63 93 14 98 - Fax : +33 5 63 93 19 03