

**NOTE:** This PDN is intended for use exclusively in EUROPE, Middle East and Africa. Additionally, the listed products are only a part of complete range.

**Product Discontinuation**

MOSFET Relay

- G3VM-101HR
- G3VM-101HR(TR)
- G3VM-101HR1
- G3VM-101HR1(TR05)
- G3VM-101LR
- G3VM-101LR(TR05)
- G3VM-21HR
- G3VM-21HR(TR)
- G3VM-21LR
- G3VM-21LR(TR05)
- G3VM-21LR1
- G3VM-21LR1(TR05)
- G3VM-21LR10
- G3VM-21LR10(TR05)
- G3VM-21LR11
- G3VM-21LR11(TR05)
- G3VM-31HR
- G3VM-31HR(TR05)
- G3VM-41GR8
- G3VM-41GR8(TR)
- G3VM-41HR
- G3VM-41HR(TR)
- G3VM-41LR10
- G3VM-41LR10(TR05)
- G3VM-41LR11
- G3VM-41LR11(TR05)
- G3VM-41LR4
- G3VM-41LR4(TR05)
- G3VM-41LR5
- G3VM-41LR5(TR05)
- G3VM-41LR6



**Recommended Replacement**

MOSFET Relay

- G3VM-101HR2
- G3VM-101HR2(TR)
- G3VM-101HR2
- G3VM-101HR2(TR05)
- G3VM-101UR
- G3VM-101UR(TR05)
- G3VM-31HR1
- G3VM-31HR1(TR05)
- G3VM-21UR10
- G3VM-21UR10(TR05)
- G3VM-21UR1
- G3VM-21UR1(TR05)
- G3VM-21UR10
- G3VM-21UR10(TR05)
- G3VM-21UR11
- G3VM-21UR11(TR05)
- G3VM-31HR1
- G3VM-31HR1(TR05)
- G3VM-61VR
- G3VM-61VR(TR)
- G3VM-61HR2
- G3VM-61HR2(TR05)
- G3VM-41UR10
- G3VM-41UR10(TR05)
- G3VM-41UR11
- G3VM-41UR11(TR05)
- G3VM-41UR4
- G3VM-41UR4(TR05)
- G3VM-41UR12
- G3VM-41UR12(TR05)
- G3VM-41UR12



G3VM-41LR6(TR05)	G3VM-41UR12(TR05)
G3VM-61HR	G3VM-61HR2
G3VM-61HR(TR)	G3VM-61HR2(TR05)
G3VM-61HR1	G3VM-61HR2
G3VM-61HR1(TR05)	G3VM-61HR2(TR05)
G3VM-61LR	G3VM-61UR
G3VM-61LR(TR05)	G3VM-61UR(TR05)
G3VM-81HR	G3VM-101HR2
G3VM-81HR(TR)	G3VM-101HR2(TR)
G3VM-81LR	G3VM-81UR
G3VM-81LR(TR05)	G3VM-81UR(TR05)

**[ Final order entry date ]**

The end of March, 2027

**[ Date of The Last Shipping ]**

The end of June, 2027

**[ Caution on recommended replacement ]**

Some products differ in body color, dimensions and mounting dimensions, but wire connection, characteristics, operation ratings and operation methods are almost compatible.

**[ Difference from discontinued product ]**

Product discontinuation	Recommended replacement Model	Body Color	Dimensions	Mounting Dimensions	Characteristics / Operation ratings	Wire connection/ Operation methods
G3VM-101HR	G3VM-101HR2	**	**	**	*	**
G3VM-101HR(TR)	G3VM-101HR2(TR)	**	**	**	*	**
G3VM-101HR1	G3VM-101HR2	**	**	**	*	**
G3VM-101HR1(TR05)	G3VM-101HR2(TR05)	**	**	**	*	**
G3VM-101LR	G3VM-101UR	--	--	--	*	**
G3VM-101LR(TR05)	G3VM-101UR(TR05)	--	--	--	*	**
G3VM-21HR	G3VM-31HR1	**	**	**	*	**
G3VM-21HR(TR)	G3VM-31HR1(TR05)	**	**	**	*	**
G3VM-21LR	G3VM-21UR10	--	--	--	*	**
G3VM-21LR(TR05)	G3VM-21UR10(TR05)	--	--	--	*	**
G3VM-21LR1	G3VM-21UR1	--	--	--	*	**
G3VM-21LR1(TR05)	G3VM-21UR1(TR05)	--	--	--	*	**
G3VM-21LR10	G3VM-21UR10	--	--	--	*	**
G3VM-21LR10(TR05)	G3VM-21UR10(TR05)	--	--	--	*	**
G3VM-21LR11	G3VM-21UR11	--	--	--	*	**
G3VM-21LR11(TR05)	G3VM-21UR11(TR05)	--	--	--	*	**
G3VM-31HR	G3VM-31HR1	**	**	**	*	**
G3VM-31HR(TR05)	G3VM-31HR1(TR05)	**	**	**	*	**
G3VM-41GR8	G3VM-61VR	--	*	**	*	**
G3VM-41GR8(TR)	G3VM-61VR(TR)	--	*	**	*	**
G3VM-41HR	G3VM-61HR2	**	**	**	*	**
G3VM-41HR(TR)	G3VM-61HR2(TR05)	**	**	**	*	**

G3VM-41LR10	G3VM-41UR10	--	--	--	*	**
G3VM-41LR10(TR05)	G3VM-41UR10(TR05)	--	--	--	*	**
G3VM-41LR11	G3VM-41UR11	--	--	--	*	**
G3VM-41LR11(TR05)	G3VM-41UR11(TR05)	--	--	--	*	**

Product discontinuation	Recommended replacement Model	Body Color	Dimensions	Mounting Dimensions	Characteristics / Operation ratings	Wire connection/ Operation methods
G3VM-41LR4	G3VM-41UR4	--	--	--	*	**
G3VM-41LR4(TR05)	G3VM-41UR4(TR05)	--	--	--	*	**
G3VM-41LR5	G3VM-41UR12	--	--	--	*	**
G3VM-41LR5(TR05)	G3VM-41UR12(TR05)	--	--	--	*	**
G3VM-41LR6	G3VM-41UR12	--	--	--	*	**
G3VM-41LR6(TR05)	G3VM-41UR12(TR05)	--	--	--	*	**
G3VM-61HR	G3VM-61HR2	**	**	**	*	**
G3VM-61HR(TR)	G3VM-61HR2(TR05)	**	**	**	*	**
G3VM-61HR1	G3VM-61HR2	**	**	**	*	**
G3VM-61HR1(TR05)	G3VM-61HR2(TR05)	**	**	**	*	**
G3VM-61LR	G3VM-61UR	--	--	--	*	**
G3VM-61LR(TR05)	G3VM-61UR(TR05)	--	--	--	*	**
G3VM-81HR	G3VM-101HR2	**	**	**	*	**
G3VM-81HR(TR)	G3VM-101HR2(TR)	**	**	**	*	**
G3VM-81LR	G3VM-81UR	--	--	--	*	**
G3VM-81LR(TR05)	G3VM-81UR(TR05)	--	--	--	*	**

\*\* : Compatible

\* : The change is a little/Almost compatible

-- : Not compatible

- : No corresponding specification

### [ Product Discontinuation and recommended replacement ]

Product discontinuation	Recommended replacement
G3VM-101HR	G3VM-101HR2
G3VM-101HR(TR)	G3VM-101HR2(TR)
G3VM-101HR1	G3VM-101HR2
G3VM-101HR1(TR05)	G3VM-101HR2(TR05)
G3VM-101LR	G3VM-101UR
G3VM-101LR(TR05)	G3VM-101UR(TR05)
G3VM-21HR	G3VM-31HR1
G3VM-21HR(TR)	G3VM-31HR1(TR05)
G3VM-21LR	G3VM-21UR10
G3VM-21LR(TR05)	G3VM-21UR10(TR05)
G3VM-21LR1	G3VM-21UR1
G3VM-21LR1(TR05)	G3VM-21UR1(TR05)
G3VM-21LR10	G3VM-21UR10
G3VM-21LR10(TR05)	G3VM-21UR10(TR05)
G3VM-21LR11	G3VM-21UR11
G3VM-21LR11(TR05)	G3VM-21UR11(TR05)
G3VM-31HR	G3VM-31HR1
G3VM-31HR(TR05)	G3VM-31HR1(TR05)

<b>Product discontinuation</b>	<b>Recommended replacement</b>
G3VM-41GR8	G3VM-61VR
G3VM-41GR8(TR)	G3VM-61VR(TR)
G3VM-41HR	G3VM-61HR2
G3VM-41HR(TR)	G3VM-61HR2(TR05)
G3VM-41LR10	G3VM-41UR10
G3VM-41LR10(TR05)	G3VM-41UR10(TR05)
G3VM-41LR11	G3VM-41UR11
G3VM-41LR11(TR05)	G3VM-41UR11(TR05)
G3VM-41LR4	G3VM-41UR4
G3VM-41LR4(TR05)	G3VM-41UR4(TR05)
G3VM-41LR5	G3VM-41UR12
G3VM-41LR5(TR05)	G3VM-41UR12(TR05)
G3VM-41LR6	G3VM-41UR12
G3VM-41LR6(TR05)	G3VM-41UR12(TR05)
G3VM-61HR	G3VM-61HR2
G3VM-61HR(TR)	G3VM-61HR2(TR05)
G3VM-61HR1	G3VM-61HR2
G3VM-61HR1(TR05)	G3VM-61HR2(TR05)
G3VM-61LR	G3VM-61UR
G3VM-61LR(TR05)	G3VM-61UR(TR05)
G3VM-81HR	G3VM-101HR2
G3VM-81HR(TR)	G3VM-101HR2(TR)
G3VM-81LR	G3VM-81UR
G3VM-81LR(TR05)	G3VM-81UR(TR05)

[ Body color ]

Product discontinuation	Recommendable replacement
G3VM-101HR G3VM-101HR(TR) G3VM-101HR1 G3VM-101HR1(TR05) G3VM-21HR G3VM-21HR(TR) G3VM-31HR G3VM-31HR(TR05) G3VM-41HR G3VM-41HR(TR) G3VM-61HR G3VM-61HR(TR) G3VM-61HR1 G3VM-61HR1(TR05) G3VM-81HR G3VM-81HR(TR)	G3VM-101HR2 G3VM-101HR2(TR) G3VM-101HR2 G3VM-101HR2(TR05) G3VM-31HR1 G3VM-31HR1(TR05) G3VM-31HR1 G3VM-31HR1(TR05) G3VM-61HR2 G3VM-61HR2(TR05) G3VM-61HR2 G3VM-61HR2(TR05) G3VM-61HR2 G3VM-61HR2(TR05) G3VM-101HR2 G3VM-101HR2(TR)
White	White

Product discontinuation	Recommendable replacement
G3VM-101LR G3VM-101LR(TR05) G3VM-21LR G3VM-21LR(TR05) G3VM-21LR1 G3VM-21LR1(TR05) G3VM-21LR10 G3VM-21LR10(TR05) G3VM-21LR11 G3VM-21LR11(TR05) G3VM-41GR8 G3VM-41GR8(TR) G3VM-41LR10 G3VM-41LR10(TR05) G3VM-41LR11 G3VM-41LR11(TR05) G3VM-41LR4 G3VM-41LR4(TR05) G3VM-41LR5 G3VM-41LR5(TR05) G3VM-41LR6 G3VM-41LR6(TR05) G3VM-61LR G3VM-61LR(TR05) G3VM-81LR G3VM-81LR(TR05)	G3VM-101UR G3VM-101UR(TR05) G3VM-21UR10 G3VM-21UR10(TR05) G3VM-21UR1 G3VM-21UR1(TR05) G3VM-21UR10 G3VM-21UR10(TR05) G3VM-21UR11 G3VM-21UR11(TR05) G3VM-61VR G3VM-61VR(TR) G3VM-41UR10 G3VM-41UR10(TR05) G3VM-41UR11 G3VM-41UR11(TR05) G3VM-41UR4 G3VM-41UR4(TR05) G3VM-41UR12 G3VM-41UR12(TR05) G3VM-41UR12 G3VM-41UR12(TR05) G3VM-61UR G3VM-61UR(TR05) G3VM-81UR G3VM-81UR(TR05)
White	Black

[ Dimensions ]

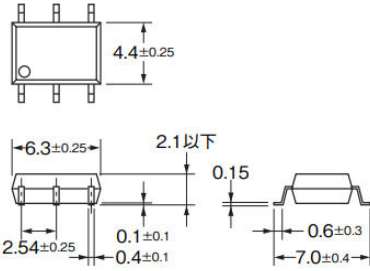
Product discontinuation	Recommendable replacement
<p>G3VM-101HR                      G3VM-101HR(TR)                      G3VM-101HR1                      G3VM-101HR1(TR05)                      G3VM-21HR                      G3VM-21HR(TR)                      G3VM-31HR                      G3VM-31HR(TR05)                      G3VM-41HR                      G3VM-41HR(TR)                      G3VM-61HR                      G3VM-61HR(TR)                      G3VM-61HR1                      G3VM-61HR1(TR05)                      G3VM-81HR                      G3VM-81HR(TR)</p>	<p>G3VM-101HR2                      G3VM-101HR2(TR)                      G3VM-101HR2                      G3VM-101HR2(TR05)                      G3VM-31HR1                      G3VM-31HR1(TR05)                      G3VM-31HR1                      G3VM-31HR1(TR05)                      G3VM-61HR2                      G3VM-61HR2(TR05)                      G3VM-61HR2                      G3VM-61HR2(TR05)                      G3VM-61HR2                      G3VM-61HR2(TR05)                      G3VM-101HR2                      G3VM-101HR2(TR)</p>
 <p>Technical drawing of a component showing top and side views with dimensions: 4.4±0.25, 6.3±0.25, 2.54±0.25, 0.1±0.1, 0.4±0.1, 2.1以下, 0.15, 0.6±0.3, 7.0±0.4.</p>	<p>Same as left</p>

[ Dimensions ]

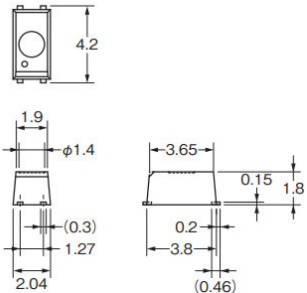
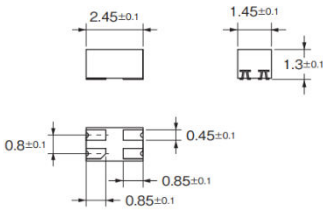
Product discontinuation	Recommendable replacement
<p>G3VM-101LR                      G3VM-101LR(TR05)                      G3VM-21LR                      G3VM-21LR(TR05)                      G3VM-21LR1                      G3VM-21LR1(TR05)                      G3VM-21LR10                      G3VM-21LR10(TR05)                      G3VM-21LR11                      G3VM-21LR11(TR05)                      G3VM-41LR10                      G3VM-41LR10(TR05)                      G3VM-41LR11                      G3VM-41LR11(TR05)                      G3VM-41LR4                      G3VM-41LR4(TR05)                      G3VM-41LR5                      G3VM-41LR5(TR05)                      G3VM-41LR6                      G3VM-41LR6(TR05)                      G3VM-61LR                      G3VM-61LR(TR05)                      G3VM-81LR                      G3VM-81LR(TR05)</p>	<p>G3VM-101UR                      G3VM-101UR(TR05)                      G3VM-21UR10                      G3VM-21UR10(TR05)                      G3VM-21UR1                      G3VM-21UR1(TR05)                      G3VM-21UR10                      G3VM-21UR10(TR05)                      G3VM-21UR11                      G3VM-21UR11(TR05)                      G3VM-41UR10                      G3VM-41UR10(TR05)                      G3VM-41UR11                      G3VM-41UR11(TR05)                      G3VM-41UR4                      G3VM-41UR4(TR05)                      G3VM-41UR12                      G3VM-41UR12(TR05)                      G3VM-41UR12                      G3VM-41UR12(TR05)                      G3VM-61UR                      G3VM-61UR(TR05)                      G3VM-81UR                      G3VM-81UR(TR05)</p>
	

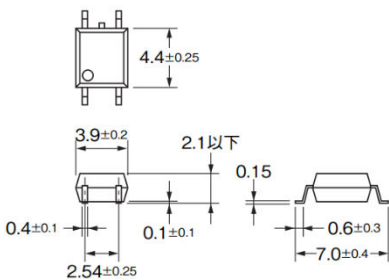
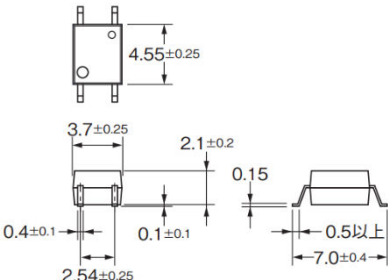
Product discontinuation	Recommendable replacement
<p>G3VM-41GR8                      G3VM-41GR8(TR)</p>	<p>G3VM-61VR                      G3VM-61VR(TR)</p>
	

[ Wire connection ]

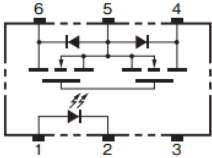
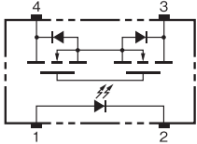
Product discontinuation	Recommendable replacement
<p>G3VM-101HR            G3VM-101HR(TR)            G3VM-101HR1            G3VM-101HR1(TR05)            G3VM-21HR            G3VM-21HR(TR)            G3VM-31HR            G3VM-31HR(TR05)            G3VM-41HR            G3VM-41HR(TR)            G3VM-61HR            G3VM-61HR(TR)            G3VM-61HR1            G3VM-61HR1(TR05)            G3VM-81HR            G3VM-81HR(TR)</p>	<p>G3VM-101HR2            G3VM-101HR2(TR)            G3VM-101HR2            G3VM-101HR2(TR05)            G3VM-31HR1            G3VM-31HR1(TR05)            G3VM-31HR1            G3VM-31HR1(TR05)            G3VM-61HR2            G3VM-61HR2(TR05)            G3VM-61HR2            G3VM-61HR2(TR05)            G3VM-61HR2            G3VM-61HR2(TR05)            G3VM-101HR2            G3VM-101HR2(TR)</p>
	<p>Same as left</p>
<p>G3VM-101LR            G3VM-101LR(TR05)            G3VM-21LR            G3VM-21LR(TR05)            G3VM-21LR1            G3VM-21LR1(TR05)            G3VM-21LR10            G3VM-21LR10(TR05)            G3VM-21LR11            G3VM-21LR11(TR05)            G3VM-41GR8            G3VM-41GR8(TR)            G3VM-41LR10            G3VM-41LR10(TR05)            G3VM-41LR11            G3VM-41LR11(TR05)            G3VM-41LR4            G3VM-41LR4(TR05)            G3VM-41LR5            G3VM-41LR5(TR05)            G3VM-41LR6            G3VM-41LR6(TR05)            G3VM-61LR            G3VM-61LR(TR05)            G3VM-81LR            G3VM-81LR(TR05)</p>	<p>G3VM-101UR            G3VM-101UR(TR05)            G3VM-21UR10            G3VM-21UR10(TR05)            G3VM-21UR1            G3VM-21UR1(TR05)            G3VM-21UR10            G3VM-21UR10(TR05)            G3VM-21UR11            G3VM-21UR11(TR05)            G3VM-61VR            G3VM-61VR(TR)            G3VM-41UR10            G3VM-41UR10(TR05)            G3VM-41UR11            G3VM-41UR11(TR05)            G3VM-41UR4            G3VM-41UR4(TR05)            G3VM-41UR12            G3VM-41UR12(TR05)            G3VM-61UR            G3VM-61UR(TR05)            G3VM-81UR            G3VM-81UR(TR05)</p>
	<p>Same as left</p>

[ Mounting dimensions ]

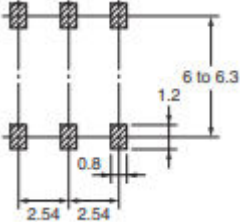
Product discontinuation	Recommendable replacement
<p>G3VM-101HR            G3VM-101HR(TR)            G3VM-101HR1            G3VM-101HR1(TR05)            G3VM-21HR            G3VM-21HR(TR)            G3VM-31HR            G3VM-31HR(TR05)            G3VM-41HR            G3VM-41HR(TR)            G3VM-61HR            G3VM-61HR(TR)            G3VM-61HR1            G3VM-61HR1(TR05)            G3VM-81HR            G3VM-81HR(TR)</p>	<p>G3VM-101HR2            G3VM-101HR2(TR)            G3VM-101HR2            G3VM-101HR2(TR05)            G3VM-31HR1            G3VM-31HR1(TR05)            G3VM-31HR1            G3VM-31HR1(TR05)            G3VM-61HR2            G3VM-61HR2(TR05)            G3VM-61HR2            G3VM-61HR2(TR05)            G3VM-61HR2            G3VM-61HR2(TR05)            G3VM-101HR2            G3VM-101HR2(TR)</p>
	<p>Same as left</p>

[ Mounting dimensions ]

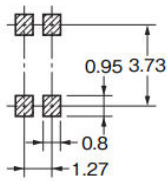
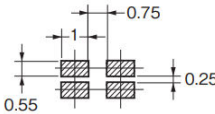
Product discontinuation	Recommendable replacement
<p>G3VM-101LR                      G3VM-101LR(TR05)                      G3VM-21LR                      G3VM-21LR(TR05)                      G3VM-21LR1                      G3VM-21LR1(TR05)                      G3VM-21LR10                      G3VM-21LR10(TR05)                      G3VM-21LR11                      G3VM-21LR11(TR05)                      G3VM-41LR10                      G3VM-41LR10(TR05)                      G3VM-41LR11                      G3VM-41LR11(TR05)                      G3VM-41LR4                      G3VM-41LR4(TR05)                      G3VM-41LR5                      G3VM-41LR5(TR05)                      G3VM-41LR6                      G3VM-41LR6(TR05)                      G3VM-61LR                      G3VM-61LR(TR05)                      G3VM-81LR                      G3VM-81LR(TR05)</p>	<p>G3VM-101UR                      G3VM-101UR(TR05)                      G3VM-21UR10                      G3VM-21UR10(TR05)                      G3VM-21UR1                      G3VM-21UR1(TR05)                      G3VM-21UR10                      G3VM-21UR10(TR05)                      G3VM-21UR11                      G3VM-21UR11(TR05)                      G3VM-41UR10                      G3VM-41UR10(TR05)                      G3VM-41UR11                      G3VM-41UR11(TR05)                      G3VM-41UR4                      G3VM-41UR4(TR05)                      G3VM-41UR12                      G3VM-41UR12(TR05)                      G3VM-41UR12                      G3VM-41UR12(TR05)                      G3VM-61UR                      G3VM-61UR(TR05)                      G3VM-81UR                      G3VM-81UR(TR05)</p>
	

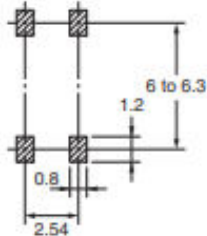
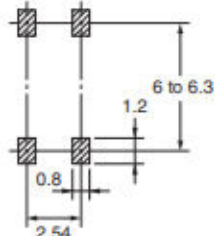
Product discontinuation	Recommendable replacement
<p>G3VM-41GR8                      G3VM-41GR8(TR)</p>	<p>G3VM-61VR                      G3VM-61VR(TR)</p>
	

[ Characteristics / Operation ratings ]

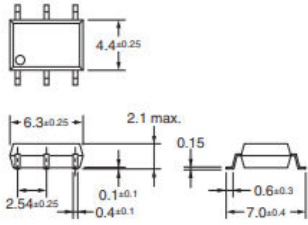
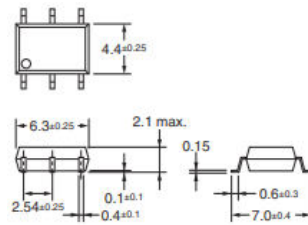
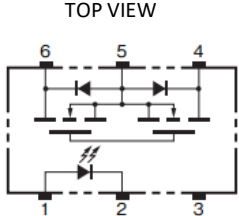
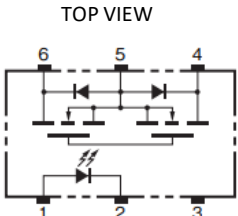
Item		Product Discontinuation			Recommended Replacement			
		G3VM-101HR G3VM-101HR(TR)			G3VM-101HR2 G3VM-101HR2(TR)			
Type								
Package		SOP6			SOP6			
Contact form		1a(SPST-NO)			1a(SPST-NO)			
Terminal structure		Surface-mounting Terminals			Surface-mounting Terminals			
Absolute maximum Rating		Symbol	Unit	Rating		Rating		
Input	LED forward current	$I_F$	mA	30		30		
	LED reverse voltage	$V_R$	V	5		6		
Output	Load Voltage(AC/DC)	$V_{OFF}$	V	100		100		
	Continuous load current	Connection A	$I_O$	A	1.4		3	
		Connection B			2.8		6	
Connection C								
Dielectric strength between input and output		$V_{LO}$	Vrms	1,500		1,500		
Operating Temperature		$T_a$	°C	-40	~	+ 85	-40 ~ + 110	
Storage Temperature		$T_{stg}$	°C	-55	~	+ 125	-55 ~ + 125	
Electrical Characteristics		Symbol	Unit	Min.	Typ.	Max	Min. Typ. Max	
Input	LED Forward voltage	$V_F$	V	1.18	1.33	1.48	1.5 1.65 1.8	
	Trigger LED Forward Current	$I_{FT}$	mA	-	0.4	3	- 0.35 3	
	Release LED Forward Current	$I_{FC}$	mA	0.1	-	-	0.1 - -	
Output	Maximum resistance with output ON	Connection A	$R_{ON}$	$\Omega$	-	0.1	0.2	- 0.05 0.065
		Connection B			-	0.05	0.1	- 0.025 0.033
		Connection C			-	0.025	-	- 0.013 0.016
Current leakage when the relay is open		$I_{LEAK}$	nA	-	-	10	- - 1000	
Capacitance between terminals		$C_{OFF}$	pF	-	1000	-	- 460 -	
Capacitance between I/O terminals		$C_{LO}$	pF	-	0.8	-	- 0.8 -	
Insulation resistance between I/O terminals		$R_{LO}$	M $\Omega$	1000	1.00E+08	-	1000 1.00E+08 -	
Turn-ON time		$t_{ON}$	ms	-	1	5	- 0.45 2	
Turn-OFF time		$t_{OFF}$	ms	-	0.15	1	- 0.1 0.5	
Approved standards		UL			UL			
Dimensions								
Terminal arrangement /Internal connections								

[ Characteristics / Operation ratings ]

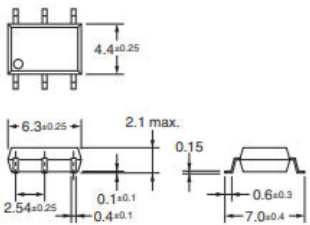
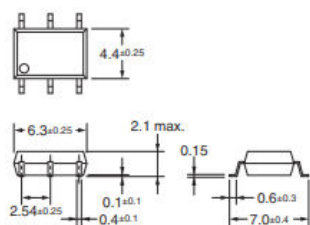
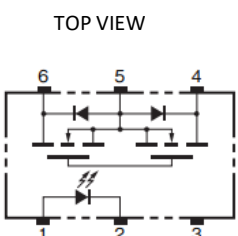
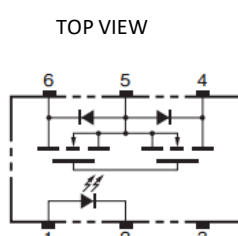
Item	Product Discontinuation			Recommended Replacement						
	G3VM-101HR1 G3VM-101HR1(TR05)			G3VM-101HR2 G3VM-101HR2(TR05)						
Type										
Package		SOP6			SOP6					
Contact form		1a(SPST-NO)			1a(SPST-NO)					
Terminal structure		Surface-mounting Terminals			Surface-mounting Terminals					
Absolute maximum Rating		Symbol	Unit	Rating		Rating				
Input	LED forward current	$I_F$	mA	30		30				
	LED reverse voltage	$V_R$	V	5		6				
Output	Load Voltage(AC/DC)	$V_{OFF}$	V	100		100				
	Continuous load current	Connection A	$I_O$	A	2.0		3			
		Connection B			4.0		6			
Connection C										
Dielectric strength between input and output		$V_{i-o}$	Vrms	1,500		1,500				
Operating Temperature		$T_a$	°C	-40	~	+ 85	-40	~	+ 110	
Storage Temperature		$T_{stg}$	°C	-55	~	+ 125	-55	~	+ 125	
Electrical Characteristics		Symbol	Unit	Min.	Typ.	Max	Min.	Typ.	Max	
Input	LED Forward voltage	$V_F$	V	1.18	1.33	1.48	1.5	1.65	1.8	
	Trigger LED Forward Current	$I_{FT}$	mA	-	0.4	3	-	0.35	3	
	Release LED Forward Current	$I_{FC}$	mA	0.1	-	-	0.1	-	-	
Output	Maximum resistance with output ON	Connection A	$R_{ON}$	$\Omega$	-	0.045	0.07	-	0.05	0.065
		Connection B			-	0.022	0.035	-	0.025	0.033
		Connection C			-	0.011	0.018	-	0.013	0.016
	Current leakage when the relay is open	$I_{LEAK}$	nA	-	-	1000	-	-	1000	
Capacitance between terminals		$C_{OFF}$	pF	-	500	-	-	460	-	
Capacitance between I/O terminals		$C_{i-o}$	pF	-	0.8	-	-	0.8	-	
Insulation resistance between I/O terminals		$R_{i-o}$	M $\Omega$	1000	1.00E+08	-	1000	1.00E+08	-	
Turn-ON time		$t_{ON}$	ms	-	1.1	5	-	0.45	2	
Turn-OFF time		$t_{OFF}$	ms	-	0.1	1	-	0.1	0.5	
Approved standards		UL			UL					
Dimensions										
Terminal arrangement /Internal connections										

[ Characteristics / Operation ratings ]

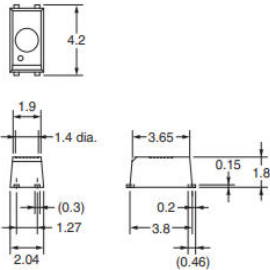
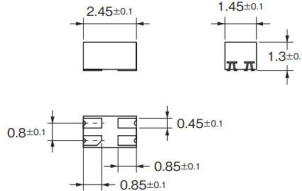
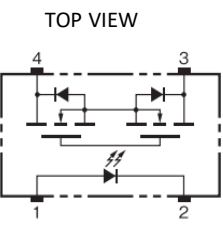
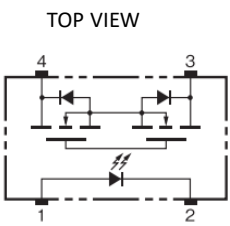
Item		Product Discontinuation			Recommended Replacement				
		G3VM-101LR G3VM-101LR(TR05)			G3VM-101UR G3VM-101UR(TR05)				
Type									
Package		SSOP4			VSON4				
Contact form		1a(SPST-NO)			1a(SPST-NO)				
Terminal structure		Surface-mounting Terminals			Surface-mounting Terminals				
Absolute maximum Rating		Symbol	Unit	Rating		Rating			
Input	LED forward current	$I_F$	mA	50		30			
	LED reverse voltage	$V_R$	V	5		5			
Output	Load Voltage(AC/DC)	$V_{OFF}$	V	100		100			
	Continuous load current	$I_O$	mA	80		100			
Dielectric strength between input and output		$V_{FO}$	Vrms	1,500		500			
Operating Temperature		$T_a$	°C	-20	~	+ 85	-40 ~ + 110		
Storage Temperature		$T_{stg}$	°C	-40	~	+ 125	-40 ~ + 125		
Electrical Characteristics		Symbol	Unit	Min.	Typ.	Max	Min.	Typ.	Max
Input	LED Forward voltage	$V_F$	V	1	1.15	1.3	1.1	1.22	1.4
	Trigger LED Forward Current	$I_{FT}$	mA	-	1	5	-	-	3
	Release LED Forward Current	$I_{FC}$	mA	0.2	-	-	0.1	-	-
Output	Maximum resistance with output ON	$R_{ON}$	$\Omega$	-	8	14	-	8	14
	Current leakage when the relay is open	$I_{LEAK}$	nA	-	-	0.2	-	-	0.2
	Capacitance between terminals	$C_{OFF}$	pF	-	6	8	-	6	8
Capacitance between I/O terminals		$C_{FO}$	pF	-	0.6	-	-	1	-
Insulation resistance between I/O terminals		$R_{LO}$	M $\Omega$	1000	1.00E+08	-	1000	1.00E+08	-
Turn-ON time		$t_{ON}$	ms	-	0.1	0.3	-	-	0.3
Turn-OFF time		$t_{OFF}$	ms	-	0.1	0.3	-	-	0.3
Approved standards		UL			-				
Dimensions									
Terminal arrangement /Internal connections									

[ Characteristics / Operation ratings ]

Item			Product Discontinuation			Recommended Replacement		
			G3VM-21HR G3VM-21HR(TR)			G3VM-31HR1 G3VM-31HR1(TR05)		
Type								
Package			SOP6			SOP6		
Contact form			1a(SPST-NO)			1a(SPST-NO)		
Terminal structure			Surface-mounting Terminals			Surface-mounting Terminals		
Absolute maximum Rating			Symbol	Unit	Rating		Rating	
Input	LED forward current		$I_F$	mA	30		30	
	LED reverse voltage		$V_R$	V	5		6	
Output	Load Voltage(AC/DC)		$V_{OFF}$	V	20		30	
	Continuous load current	Connection A	$I_O$	A	2.5		4.5	
		Connection B			5.0		9	
Connection C								
Dielectric strength between input and output			$V_{iO}$	Vrms	1,500		1,500	
Operating Temperature			$T_a$	°C	-40	~	+ 85	-40 ~ + 110
Storage Temperature			$T_{stg}$	°C	-55	~	+ 125	-55 ~ + 125
Electrical Characteristics			Symbol	Unit	Min.	Typ.	Max	Min. Typ. Max
Input	LED Forward voltage		$V_F$	V	1.18	1.33	1.48	1.5 1.65 1.8
	Trigger LED Forward Current		$I_{FT}$	mA	-	-	3	- 0.3 3
	Release LED Forward Current		$I_{FC}$	mA	0.1	-	-	0.1 - -
Output	Maximum resistance with output ON	Connection A	$R_{ON}$	$\Omega$	-	0.02	0.05	- 0.022 0.03
		Connection B			-	0.01	0.025	- 0.011 0.015
		Connection C			-	0.005	-	- 0.006 0.008
Current leakage when the relay is open		$I_{LEAK}$	nA	-	-	10	- - 1000	
Capacitance between terminals		$C_{OFF}$	pF	-	1000	-	- 1200 -	
Capacitance between I/O terminals		$C_{iO}$	pF	-	0.8	-	- 0.8 -	
Insulation resistance between I/O terminals		$R_{iO}$	M $\Omega$	1000	1.00E+08	-	1000 1.00E+08 -	
Turn-ON time		$t_{ON}$	ms	-	1.5	5	- 0.6 2	
Turn-OFF time		$t_{OFF}$	ms	-	0.1	1	- 0.15 0.5	
Approved standards			UL			UL		
Dimensions								
Terminal arrangement /Internal connections			<p>TOP VIEW</p>			<p>TOP VIEW</p>		

[ Characteristics / Operation ratings ]

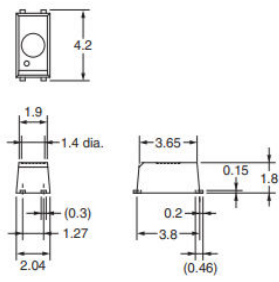
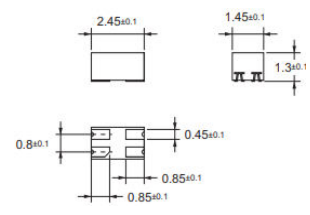
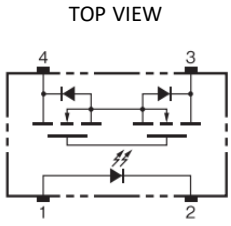
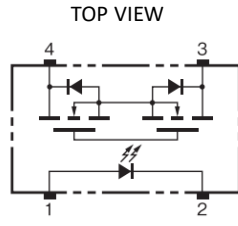
Item		Product Discontinuation			Recommended Replacement				
		G3VM-21LR G3VM-21LR(TR05)			G3VM-21UR10 G3VM-21UR10(TR05)				
Type									
Package		SSOP4			VSON4				
Contact form		1a(SPST-NO)			1a(SPST-NO)				
Terminal structure		Surface-mounting Terminals			Surface-mounting Terminals				
Absolute maximum Rating		Symbol	Unit	Rating		Rating			
Input	LED forward current	$I_F$	mA	50		30			
	LED reverse voltage	$V_R$	V	5		5			
Output	Load Voltage(AC/DC)	$V_{OFF}$	V	20		20			
	Continuous load current	$I_O$	mA	160		200			
Dielectric strength between input and output		$V_{LO}$	Vrms	1,500		500			
Operating Temperature		$T_a$	°C	-20	~	+ 85	-40 ~ + 110		
Storage Temperature		$T_{stg}$	°C	-40	~	+ 125	-40 ~ + 125		
Electrical Characteristics		Symbol	Unit	Min.	Typ.	Max	Min.	Typ.	Max
Input	LED Forward voltage	$V_F$	V	1	1.15	1.3	1.1	1.22	1.4
	Trigger LED Forward Current	$I_{FT}$	mA	-	-	4	-	0.9	3
	Release LED Forward Current	$I_{FC}$	mA	0.2	-	-	0.1	-	-
Output	Maximum resistance with output ON	$R_{ON}$	$\Omega$	-	5	8	-	3	5
	Current leakage when the relay is open	$I_{LEAK}$	nA	-	-	1	-	-	1
	Capacitance between terminals	$C_{OFF}$	pF	-	1	2.5	-	0.8	1.1
Capacitance between I/O terminals		$C_{LO}$	pF	-	0.8	-	-	1	-
Insulation resistance between I/O terminals		$R_{LO}$	M $\Omega$	1000	1.00E+08	-	1000	1.00E+08	-
Turn-ON time		$t_{ON}$	ms	-	0.06	0.5	-	0.05	0.2
Turn-OFF time		$t_{OFF}$	ms	-	0.12	0.5	-	0.02	0.2
Approved standards		UL			-				
Dimensions									
Terminal arrangement /Internal connections									

[ Characteristics / Operation ratings ]

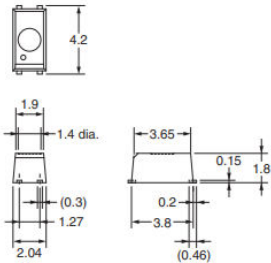
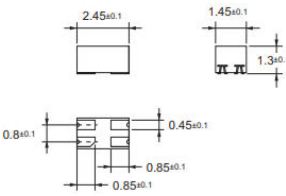
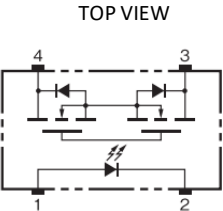
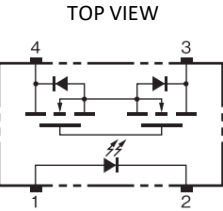
Item		Product Discontinuation				Recommended Replacement			
		G3VM-21LR1 G3VM-21LR1(TR05)				G3VM-21UR1 G3VM-21UR1(TR05)			
Type									
Package		SSOP4				VSON4			
Contact form		1a(SPST-NO)				1a(SPST-NO)			
Terminal structure		Surface-mounting Terminals				Surface-mounting Terminals			
Absolute maximum Rating		Symbol	Unit	Rating			Rating		
Input	LED forward current	$I_F$	mA	50			30		
	LED reverse voltage	$V_R$	V	5			5		
Output	Load Voltage(AC/DC)	$V_{OFF}$	V	20			20		
	Continuous load current	$I_O$	mA	450			450		
Dielectric strength between input and output		$V_{LO}$	Vrms	1,500			500		
Operating Temperature		$T_a$	°C	-20	~	+ 85	-40	~	+ 110
Storage Temperature		$T_{stg}$	°C	-40	~	+ 125	-40	~	+ 125
Electrical Characteristics		Symbol	Unit	Min.	Typ.	Max	Min.	Typ.	Max
Input	LED Forward voltage	$V_F$	V	1	1.15	1.3	1.1	1.22	1.4
	Trigger LED Forward Current	$I_{FT}$	mA	-	-	4	-	0.6	3
	Release LED Forward Current	$I_{FC}$	mA	0.2	-	-	0.1	-	-
Output	Maximum resistance with output ON	$R_{ON}$	Ω	-	0.8	1.2	-	0.8	1.2
	Current leakage when the relay is open	$I_{LEAK}$	nA	-	-	1	-	-	1
	Capacitance between terminals	$C_{OFF}$	pF	-	5	12	-	5	12
Capacitance between I/O terminals		$C_{LO}$	pF	-	0.8	-	-	1	-
Insulation resistance between I/O terminals		$R_{LO}$	MΩ	1000	1.00E+08	-	1000	1.00E+08	-
Turn-ON time		$t_{ON}$	ms	-	0.2	0.5	-	0.17	0.4
Turn-OFF time		$t_{OFF}$	ms	-	0.2	0.5	-	0.03	0.4
Approved standards		UL				-			
Dimensions									
Terminal arrangement /Internal connections									

[ Characteristics / Operation ratings ]

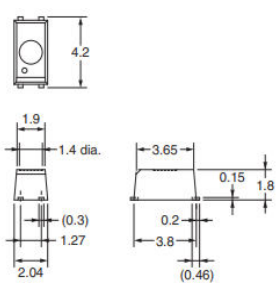
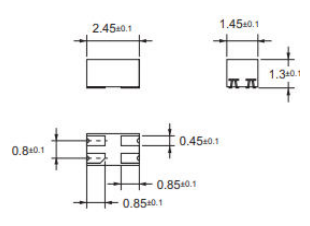
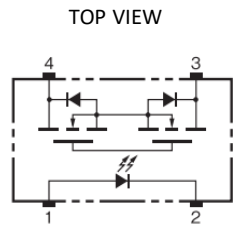
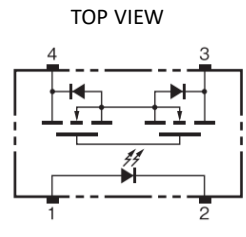
Item				Product Discontinuation			Recommended Replacement				
				G3VM-21LR10 G3VM-21LR10(TR05)			G3VM-21UR10 G3VM-21UR10(TR05)				
Type											
Package				SSOP4			VSON4				
Contact form				1a(SPST-NO)			1a(SPST-NO)				
Terminal structure				Surface-mounting Terminals			Surface-mounting Terminals				
Absolute maximum Rating				Symbol	Unit	Rating		Rating			
Input	LED forward current			$I_F$	mA	30		30			
	LED reverse voltage			$V_R$	V	5		5			
Output	Load Voltage(AC/DC)			$V_{OFF}$	V	20		20			
	Continuous load current			$I_O$	mA	200		200			
Dielectric strength between input and output				$V_{L-O}$	Vrms	1,500		500			
Operating Temperature				$T_a$	°C	-20	~	+ 85	-40	~	+ 110
Storage Temperature				$T_{sig}$	°C	-40	~	+ 125	-40	~	+ 125
Electrical Characteristics				Symbol	Unit	Min.	Typ.	Max	Min.	Typ.	Max
Input	LED Forward voltage			$V_F$	V	1.15	1.35	1.45	1.1	1.22	1.4
	Trigger LED Forward Current			$I_{FT}$	mA	-	-	3	-	0.9	3
	Release LED Forward Current			$I_{FC}$	mA	0.1	-	-	0.1	-	-
Output	Maximum resistance with output ON			$R_{ON}$	Ω	-	3	5	-	3	5
	Current leakage when the relay is open			$I_{LEAK}$	nA	-	0.01	0.2	-	-	1
	Capacitance between terminals			$C_{OFF}$	pF	-	0.8	1.1	-	0.8	1.1
Capacitance between I/O terminals				$C_{I-O}$	pF	-	0.3	-	-	1	-
Insulation resistance between I/O terminals				$R_{I-O}$	MΩ	1000	1.00E+08	-	1000	1.00E+08	-
Turn-ON time				$t_{ON}$	ms	-	-	0.2	-	0.05	0.2
Turn-OFF time				$t_{OFF}$	ms	-	-	0.2	-	0.02	0.2
Approved standards				UL			-				
Dimensions											
Terminal arrangement /Internal connections											

[ Characteristics / Operation ratings ]

Item		Product Discontinuation				Recommended Replacement			
		G3VM-21LR11 G3VM-21LR11(TR05)				G3VM-21UR11 G3VM-21UR11(TR05)			
Type									
Package		SSOP4				VSON4			
Contact form		1a(SPST-NO)				1a(SPST-NO)			
Terminal structure		Surface-mounting Terminals				Surface-mounting Terminals			
Absolute maximum Rating		Symbol	Unit	Rating			Rating		
Input	LED forward current	$I_F$	mA	50			30		
	LED reverse voltage	$V_R$	V	5			5		
Output	Load Voltage(AC/DC)	$V_{OFF}$	V	20			20		
	Continuous load current	$I_O$	mA	900			1,000		
Dielectric strength between input and output		$V_{LO}$	Vrms	1,500			500		
Operating Temperature		$T_a$	°C	-20	~	+ 85	-40	~	+ 110
Storage Temperature		$T_{stg}$	°C	-40	~	+ 125	-40	~	+ 125
Electrical Characteristics		Symbol	Unit	Min.	Typ.	Max	Min.	Typ.	Max
Input	LED Forward voltage	$V_F$	V	1	1.15	1.3	1.1	1.22	1.4
	Trigger LED Forward Current	$I_{FT}$	mA	-	-	3	-	-	3
	Release LED Forward Current	$I_{FC}$	mA	0.1	-	-	0.1	-	-
Output	Maximum resistance with output ON	$R_{ON}$	$\Omega$	-	0.18	0.22	-	0.18	0.22
	Current leakage when the relay is open	$I_{LEAK}$	nA	-	-	1	-	-	1
	Capacitance between terminals	$C_{OFF}$	pF	-	40	-	-	40	-
Capacitance between I/O terminals		$C_{LO}$	pF	-	0.3	-	-	1	-
Insulation resistance between I/O terminals		$R_{LO}$	M $\Omega$	1000	1.00E+08	-	1000	1.00E+08	-
Turn-ON time		$t_{ON}$	ms	-	0.3	2	-	-	2
Turn-OFF time		$t_{OFF}$	ms	-	0.2	1	-	-	1
Approved standards		UL				-			
Dimensions									
Terminal arrangement /Internal connections		<p>TOP VIEW</p>				<p>TOP VIEW</p>			

[ Characteristics / Operation ratings ]

Item			Product Discontinuation			Recommended Replacement		
			G3VM-31HR G3VM-31HR(TR05)			G3VM-31HR1 G3VM-31HR1(TR05)		
Type								
Package			SOP6			SOP6		
Contact form			1a(SPST-NO)			1a(SPST-NO)		
Terminal structure			Surface-mounting Terminals			Surface-mounting Terminals		
Absolute maximum Rating			Symbol	Unit	Rating		Rating	
Input	LED forward current		$I_F$	mA	30		30	
	LED reverse voltage		$V_R$	V	5		6	
Output	Load Voltage(AC/DC)		$V_{OFF}$	V	30		30	
	Continuous load current	Connection A	$I_O$	A	4.0		4.5	
		Connection B			8.0		9	
Connection C								
Dielectric strength between input and output			$V_{iO}$	Vrms	1,500		1,500	
Operating Temperature			$T_a$	°C	-40	~	+ 85	-40 ~ + 110
Storage Temperature			$T_{stg}$	°C	-55	~	+ 125	-55 ~ + 125
Electrical Characteristics			Symbol	Unit	Min.	Typ.	Max	Min. Typ. Max
Input	LED Forward voltage		$V_F$	V	1.18	1.33	1.48	1.5 1.65 1.8
	Trigger LED Forward Current		$I_{FT}$	mA	-	0.3	3	- 0.3 3
	Release LED Forward Current		$I_{FC}$	mA	0.1	-	-	0.1 - -
Output	Maximum resistance with output ON	Connection A	$R_{ON}$	$\Omega$	-	0.02	0.04	- 0.022 0.03
		Connection B			-	0.008	0.02	- 0.011 0.015
		Connection C			-	0.004	0.01	- 0.006 0.008
	Current leakage when the relay is open		$I_{LEAK}$	nA	-	-	1000	- - 1000
Capacitance between terminals		$C_{OFF}$	pF	-	1100	-	- 1200 -	
Capacitance between I/O terminals			$C_{iO}$	pF	-	0.8	-	- 0.8 -
Insulation resistance between I/O terminals			$R_{iO}$	M $\Omega$	1000	1.00E+08	-	1000 1.00E+08 -
Turn-ON time			$t_{ON}$	ms	-	1.1	5	- 0.6 2
Turn-OFF time			$t_{OFF}$	ms	-	0.1	1	- 0.15 0.5
Approved standards			UL			UL		
Dimensions								
Terminal arrangement /Internal connections			<p>TOP VIEW</p>			<p>TOP VIEW</p>		

[ Characteristics / Operation ratings ]

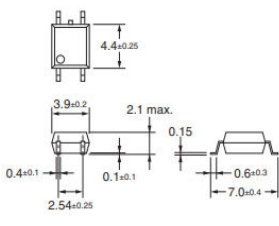
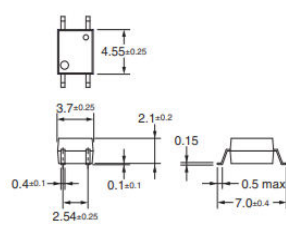
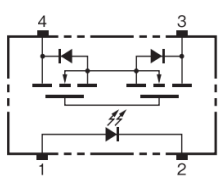
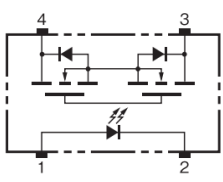
Item			Product Discontinuation			Recommended Replacement				
			G3VM-41GR8 G3VM-41GR8(TR)			G3VM-61VR G3VM-61VR(TR)				
Type										
Package			SOP4			Special SOP4				
Contact form			1a(SPST-NO)			1a(SPST-NO)				
Terminal structure			Surface-mounting Terminals			Surface-mounting Terminals				
Absolute maximum Rating			Symbol	Unit	Rating		Rating			
Input	LED forward current	$I_F$	mA	30		50				
	LED reverse voltage	$V_R$	V	5		6				
Output	Load Voltage(AC/DC)	$V_{OFF}$	V	40		60				
	Continuous load current	$I_O$	A	1		1.4				
Dielectric strength between input and output			$V_{LO}$	Vrms	1,500		3,750			
Operating Temperature			$T_a$	°C	-40	~	+ 85	-40 ~ + 110		
Storage Temperature			$T_{stg}$	°C	-55	~	+ 125	-40 ~ + 125		
Electrical Characteristics			Symbol	Unit	Min.	Typ.	Max	Min.	Typ.	Max
Input	LED Forward voltage	$V_F$	V	1.18	1.33	1.48	1.1	1.27	1.4	
	Trigger LED Forward Current	$I_{FT}$	mA	-	1	3	-	1	3	
	Release LED Forward Current	$I_{FC}$	mA	0.1	-	-	0.1	-	-	
Output	Maximum resistance with output ON	$R_{ON}$	mΩ	-	100	130	-	130	250	
	Current leakage when the relay is open	$I_{LEAK}$	nA	-	-	1	-	2	1000	
	Capacitance between terminals	$C_{OFF}$	pF	-	300	-	-	100	-	
Capacitance between I/O terminals			$C_{LO}$	pF	-	0.8	-	-	0.8	-
Insulation resistance between I/O terminals			$R_{LO}$	MΩ	1000	1.00E+08	-	1000	1.00E+08	-
Turn-ON time			$t_{ON}$	ms	-	1.2	3	-	2	3
Turn-OFF time			$t_{OFF}$	ms	-	0.2	0.5	-	0.1	1
Approved standards			UL			UL				
Dimensions										
Terminal arrangement /Internal connections			<p>TOP VIEW</p> 			<p>TOP VIEW</p> 				

[ Characteristics / Operation ratings ]

Item			Product Discontinuation			Recommended Replacement		
			G3VM-41HR G3VM-41HR(TR)			G3VM-61HR2 G3VM-61HR2(TR05)		
Type								
Package			SOP6			SOP6		
Contact form			1a(SPST-NO)			1a(SPST-NO)		
Terminal structure			Surface-mounting Terminals			Surface-mounting Terminals		
Absolute maximum Rating			Symbol	Unit	Rating		Rating	
Input	LED forward current		$I_F$	mA	30		30	
	LED reverse voltage		$V_R$	V	5		6	
Output	Load Voltage(AC/DC)		$V_{OFF}$	V	40		60	
	Continuous load current	Connection A	$I_O$	A	2.5		4.0	
		Connection B			5.0		8	
Connection C								
Dielectric strength between input and output			$V_{iO}$	Vrms	1,500		1,500	
Operating Temperature			$T_a$	°C	-40	~	+ 85	-40 ~ + 110
Storage Temperature			$T_{stg}$	°C	-55	~	+ 125	-55 ~ + 125
Electrical Characteristics			Symbol	Unit	Min.	Typ.	Max	Min. Typ. Max
Input	LED Forward voltage		$V_F$	V	1.18	1.33	1.48	1.5 1.65 1.8
	Trigger LED Forward Current		$I_{FT}$	mA	-	0.4	3	- 0.3 3
	Release LED Forward Current		$I_{FC}$	mA	0.1	-	-	0.1 - -
Output	Maximum resistance with output ON	Connection A	$R_{ON}$	$\Omega$	-	0.03	0.06	- 0.028 0.04
		Connection B			-	0.015	0.03	- 0.014 0.02
		Connection C			-	0.008	-	- 0.007 0.01
Current leakage when the relay is open		$I_{LEAK}$	nA	-	-	10	- - 1000	
Capacitance between terminals		$C_{OFF}$	pF	-	1000	-	- 750 -	
Capacitance between I/O terminals		$C_{iO}$	pF	-	0.8	-	- 0.8 -	
Insulation resistance between I/O terminals		$R_{iO}$	M $\Omega$	1000	1.00E+08	-	1000 1.00E+08 -	
Turn-ON time		$t_{ON}$	ms	-	1	5	- 0.6 2	
Turn-OFF time		$t_{OFF}$	ms	-	0.15	1	- 0.15 0.5	
Approved standards			UL			UL		
Dimensions								
Terminal arrangement /Internal connections			<p>TOP VIEW</p>			<p>TOP VIEW</p>		

[ Characteristics / Operation ratings ]

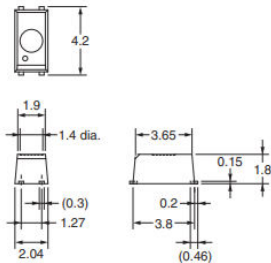
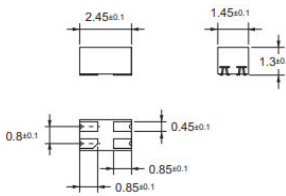
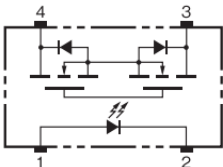
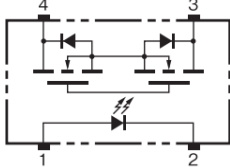
Item		Product Discontinuation				Recommended Replacement			
		G3VM-41LR10 G3VM-41LR10(TR05)				G3VM-41UR10 G3VM-41UR10(TR05)			
Type									
Package		SSOP4				VSON4			
Contact form		1a(SPST-NO)				1a(SPST-NO)			
Terminal structure		Surface-mounting Terminals				Surface-mounting Terminals			
Absolute maximum Rating		Symbol	Unit	Rating			Rating		
Input	LED forward current	$I_F$	mA	30			30		
	LED reverse voltage	$V_R$	V	5			5		
Output	Load Voltage(AC/DC)	$V_{OFF}$	V	40			40		
	Continuous load current	$I_O$	A	0.12			0.12		
Dielectric strength between input and output		$V_{LO}$	Vrms	1,500			500		
Operating Temperature		$T_a$	°C	-20	~	+ 85	-40	~	+ 110
Storage Temperature		$T_{stg}$	°C	-40	~	+ 125	-40	~	+ 125
Electrical Characteristics		Symbol	Unit	Min.	Typ.	Max	Min.	Typ.	Max
Input	LED Forward voltage	$V_F$	V	1.15	1.35	1.45	1.1	1.27	1.4
	Trigger LED Forward Current	$I_{FT}$	mA	-	-	3	-	-	3
	Release LED Forward Current	$I_{FC}$	mA	0.1	-	-	0.1	-	-
Output	Maximum resistance with output ON	$R_{ON}$	Ω	-	12	14	-	12	14
	Current leakage when the relay is open	$I_{LEAK}$	nA	-	0.01	0.2	-	-	1
	Capacitance between terminals	$C_{OFF}$	pF	-	0.45	0.8	-	0.45	0.8
Capacitance between I/O terminals		$C_{LO}$	pF	-	0.3	-	-	1	-
Insulation resistance between I/O terminals		$R_{LO}$	MΩ	1000	1.00E+08	-	1000	1.00E+08	-
Turn-ON time		$t_{ON}$	ms	-	-	0.2	-	-	0.2
Turn-OFF time		$t_{OFF}$	ms	-	-	0.3	-	-	0.3
Approved standards		UL				-			
Dimensions									
Terminal arrangement /Internal connections		<p>TOP VIEW</p> 				<p>TOP VIEW</p> 			

[ Characteristics / Operation ratings ]

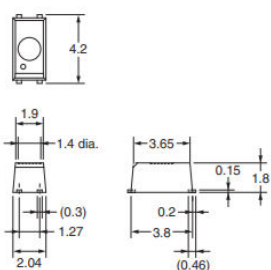
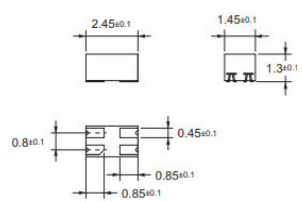
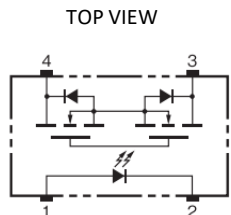
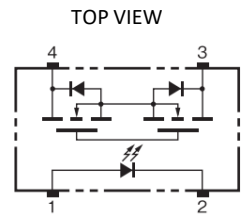
Item		Product Discontinuation				Recommended Replacement			
		G3VM-41LR11 G3VM-41LR11(TR05)				G3VM-41UR11 G3VM-41UR11(TR05)			
Type									
Package		SSOP4				VSON4			
Contact form		1a(SPST-NO)				1a(SPST-NO)			
Terminal structure		Surface-mounting Terminals				Surface-mounting Terminals			
Absolute maximum Rating		Symbol	Unit	Rating			Rating		
Input	LED forward current	$I_F$	mA	30			30		
	LED reverse voltage	$V_R$	V	5			5		
Output	Load Voltage(AC/DC)	$V_{OFF}$	V	40			40		
	Continuous load current	$I_O$	A	0.14			0.14		
Dielectric strength between input and output		$V_{LO}$	Vrms	1,500			500		
Operating Temperature		$T_a$	°C	-20	~	+ 85	-40	~	+ 110
Storage Temperature		$T_{stg}$	°C	-40	~	+ 125	-40	~	+ 125
Electrical Characteristics		Symbol	Unit	Min.	Typ.	Max	Min.	Typ.	Max
Input	LED Forward voltage	$V_F$	V	1.15	1.3	1.45	1.1	1.27	1.4
	Trigger LED Forward Current	$I_{FT}$	mA	-	-	3	-	0.7	3
	Release LED Forward Current	$I_{FC}$	mA	0.1	-	-	0.1	-	-
Output	Maximum resistance with output ON	$R_{ON}$	$\Omega$	-	7	10	-	5	10
	Current leakage when the relay is open	$I_{LEAK}$	nA	-	0.01	0.2	-	-	1
	Capacitance between terminals	$C_{OFF}$	pF	-	0.7	1.3	-	0.7	1.3
Capacitance between I/O terminals		$C_{LO}$	pF	-	0.3	-	-	1	-
Insulation resistance between I/O terminals		$R_{LO}$	M $\Omega$	1000	1.00E+08	-	1000	1.00E+08	-
Turn-ON time		$t_{ON}$	ms	-	-	0.2	-	0.06	0.2
Turn-OFF time		$t_{OFF}$	ms	-	-	0.2	-	0.03	0.2
Approved standards		UL				-			
Dimensions									
Terminal arrangement /Internal connections									

[ Characteristics / Operation ratings ]

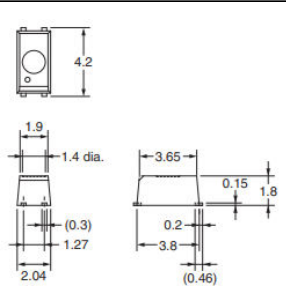
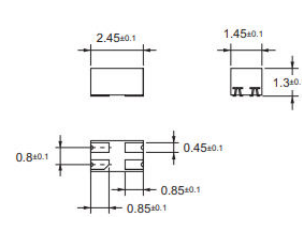
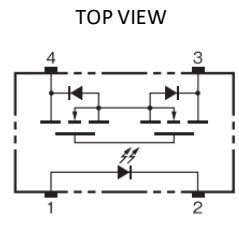
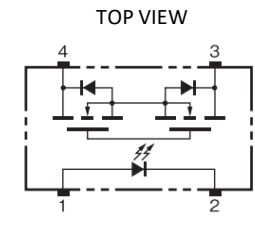
Item		Product Discontinuation				Recommended Replacement			
		G3VM-41LR4 G3VM-41LR4(TR05)				G3VM-41UR4 G3VM-41UR4(TR05)			
Type									
Package		SSOP4				VSON4			
Contact form		1a(SPST-NO)				1a(SPST-NO)			
Terminal structure		Surface-mounting Terminals				Surface-mounting Terminals			
Absolute maximum Rating		Symbol	Unit	Rating			Rating		
Input	LED forward current	$I_F$	mA	50			30		
	LED reverse voltage	$V_R$	V	5			6		
Output	Load Voltage(AC/DC)	$V_{OFF}$	V	40			40		
	Continuous load current	$I_O$	mA	250			250		
Dielectric strength between input and output		$V_{LO}$	Vrms	1,500			500		
Operating Temperature		$T_a$	°C	-20	~	+ 85	-40	~	+ 110
Storage Temperature		$T_{stg}$	°C	-40	~	+ 125	-40	~	+ 125
Electrical Characteristics		Symbol	Unit	Min.	Typ.	Max	Min.	Typ.	Max
Input	LED Forward voltage	$V_F$	V	1	1.15	1.3	1.1	1.27	1.4
	Trigger LED Forward Current	$I_{FT}$	mA	-	-	4	-	0.8	3
	Release LED Forward Current	$I_{FC}$	mA	0.2	-	-	0.1	-	-
Output	Maximum resistance with output ON	$R_{ON}$	Ω	-	2	3	-	2	3
	Current leakage when the relay is open	$I_{LEAK}$	nA	-	-	1	-	-	1
	Capacitance between terminals	$C_{OFF}$	pF	-	5	7	-	5	7
Capacitance between I/O terminals		$C_{LO}$	pF	-	0.8	-	-	1	-
Insulation resistance between I/O terminals		$R_{LO}$	MΩ	1000	1.00E+08	-	1000	1.00E+08	-
Turn-ON time		$t_{ON}$	ms	-	0.12	0.5	-	0.08	0.3
Turn-OFF time		$t_{OFF}$	ms	-	0.14	0.5	-	0.04	0.3
Approved standards		UL				-			
Dimensions									
Terminal arrangement /Internal connections									

[ Characteristics / Operation ratings ]

Item			Product Discontinuation			Recommended Replacement		
			G3VM-41LR5 G3VM-41LR5(TR05)			G3VM-41UR12 G3VM-41UR12(TR05)		
Type								
Package			SSOP4			VSON4		
Contact form			1a(SPST-NO)			1a(SPST-NO)		
Terminal structure			Surface-mounting Terminals			Surface-mounting Terminals		
Absolute maximum Rating			Symbol	Unit	Rating		Rating	
Input	LED forward current		$I_F$	mA	50		30	
	LED reverse voltage		$V_R$	V	5		5	
Output	Load Voltage(AC/DC)		$V_{OFF}$	V	40		40	
	Continuous load current		$I_O$	mA	300		100	
Dielectric strength between input and output			$V_{LO}$	Vrms	1,500		500	
Operating Temperature			$T_a$	°C	-20	~	+ 85	-40 ~ + 110
Storage Temperature			$T_{stg}$	°C	-40	~	+ 125	-40 ~ + 125
Electrical Characteristics			Symbol	Unit	Min.	Typ.	Max	Min. Typ. Max
Input	LED Forward voltage		$V_F$	V	1	1.15	1.3	1.1 1.27 1.4
	Trigger LED Forward Current		$I_{FT}$	mA	-	-	4	- 0.9 3
	Release LED Forward Current		$I_{FC}$	mA	0.2	-	-	0.1 - -
Output	Maximum resistance with output ON		$R_{ON}$	Ω	-	1	1.5	- 15 20
	Current leakage when the relay is open		$I_{LEAK}$	nA	-	-	1	- - 1
	Capacitance between terminals		$C_{OFF}$	pF	-	10	14	- 0.3 0.6
Capacitance between I/O terminals			$C_{LO}$	pF	-	0.8	-	- 1 -
Insulation resistance between I/O terminals			$R_{LO}$	MΩ	1000	1.00E+08	-	1000 1.00E+08 -
Turn-ON time			$t_{ON}$	ms	-	0.2	0.5	- 0.05 0.2
Turn-OFF time			$t_{OFF}$	ms	-	0.2	0.5	- 0.03 0.2
Approved standards			UL			-		
Dimensions								
Terminal arrangement /Internal connections								

[ Characteristics / Operation ratings ]

Item			Product Discontinuation			Recommended Replacement			
			G3VM-41LR6 G3VM-41LR6(TR05)			G3VM-41UR12 G3VM-41UR12(TR05)			
Type									
Package			SSOP4			VSON4			
Contact form			1a(SPST-NO)			1a(SPST-NO)			
Terminal structure			Surface-mounting Terminals			Surface-mounting Terminals			
Absolute maximum Rating		Symbol	Unit	Rating			Rating		
Input	LED forward current	$I_F$	mA	50			30		
	LED reverse voltage	$V_R$	V	5			5		
Output	Load Voltage(AC/DC)	$V_{OFF}$	V	40			40		
	Continuous load current	$I_O$	mA	120			100		
Dielectric strength between input and output		$V_{LO}$	Vrms	1,500			500		
Operating Temperature		$T_a$	°C	-20	~	+ 85	-40	~	+ 110
Storage Temperature		$T_{stg}$	°C	-40	~	+ 125	-40	~	+ 125
Electrical Characteristics		Symbol	Unit	Min.	Typ.	Max	Min.	Typ.	Max
Input	LED Forward voltage	$V_F$	V	1	1.15	1.3	1.1	1.27	1.4
	Trigger LED Forward Current	$I_{FT}$	mA	-	-	4	-	0.9	3
	Release LED Forward Current	$I_{FC}$	mA	0.2	-	-	0.1	-	-
Output	Maximum resistance with output ON	$R_{ON}$	Ω	-	10	15	-	15	20
	Current leakage when the relay is open	$I_{LEAK}$	nA	-	-	1	-	-	1
	Capacitance between terminals	$C_{OFF}$	pF	-	1	2	-	0.3	0.6
Capacitance between I/O terminals		$C_{LO}$	pF	-	0.8	-	-	1	-
Insulation resistance between I/O terminals		$R_{LO}$	MΩ	1000	1.00E+08	-	1000	1.00E+08	-
Turn-ON time		$t_{ON}$	ms	-	0.05	0.5	-	0.05	0.2
Turn-OFF time		$t_{OFF}$	ms	-	0.12	0.5	-	0.03	0.2
Approved standards			UL			-			
Dimensions									
Terminal arrangement /Internal connections									

[ Characteristics / Operation ratings ]

Item			Product Discontinuation			Recommended Replacement		
			G3VM-61HR G3VM-61HR(TR)			G3VM-61HR2 G3VM-61HR2(TR05)		
Type								
Package			SOP6			SOP6		
Contact form			1a(SPST-NO)			1a(SPST-NO)		
Terminal structure			Surface-mounting Terminals			Surface-mounting Terminals		
Absolute maximum Rating			Symbol	Unit	Rating		Rating	
Input	LED forward current		$I_F$	mA	30		30	
	LED reverse voltage		$V_R$	V	5		6	
Output	Load Voltage(AC/DC)		$V_{OFF}$	V	60		60	
	Continuous load current	Connection A	$I_O$	A	2.3		4.0	
		Connection B			4.6		8	
Connection C								
Dielectric strength between input and output			$V_{LO}$	Vrms	1,500		1,500	
Operating Temperature			$T_a$	°C	-40	~	+ 85	-40 ~ + 110
Storage Temperature			$T_{stg}$	°C	-55	~	+ 125	-55 ~ + 125
Electrical Characteristics			Symbol	Unit	Min.	Typ.	Max	Min. Typ. Max
Input	LED Forward voltage		$V_F$	V	1.18	1.33	1.48	1.5 1.65 1.8
	Trigger LED Forward Current		$I_{FT}$	mA	-	0.4	3	- 0.3 3
	Release LED Forward Current		$I_{FC}$	mA	0.1	-	-	0.1 - -
Output	Maximum resistance with output ON	Connection A	$R_{ON}$	$\Omega$	-	0.04	0.07	- 0.028 0.04
		Connection B			-	0.02	0.04	- 0.014 0.02
		Connection C			-	0.01	-	- 0.007 0.01
Current leakage when the relay is open		$I_{LEAK}$	nA	-	-	10	- - 1000	
Capacitance between terminals		$C_{OFF}$	pF	-	1000	-	- 750 -	
Capacitance between I/O terminals		$C_{LO}$	pF	-	0.8	-	- 0.8 -	
Insulation resistance between I/O terminals		$R_{LO}$	M $\Omega$	1000	1.00E+08	-	1000 1.00E+08 -	
Turn-ON time		$t_{ON}$	ms	-	1	5	- 0.6 2	
Turn-OFF time		$t_{OFF}$	ms	-	0.15	1	- 0.15 0.5	
Approved standards			UL			UL		
Dimensions								
Terminal arrangement /Internal connections			<p>TOP VIEW</p>			<p>TOP VIEW</p>		

[ Characteristics / Operation ratings ]

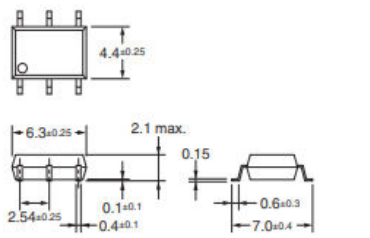
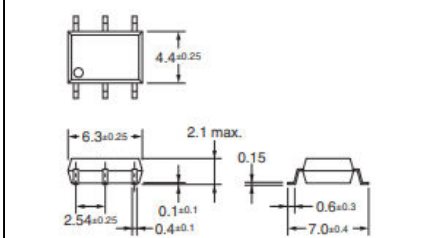
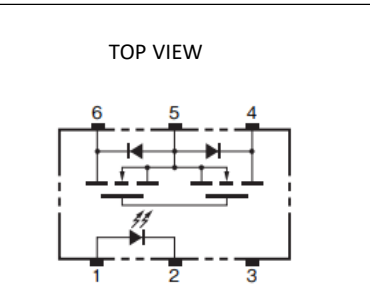
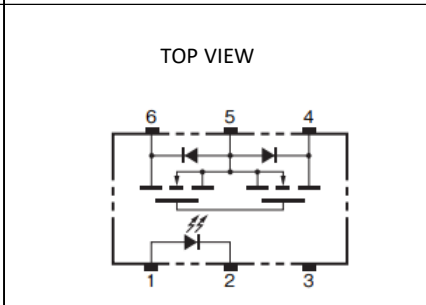
Item	Product Discontinuation			Recommended Replacement						
	G3VM-61HR1 G3VM-61HR1(TR05)			G3VM-61HR2 G3VM-61HR2(TR05)						
Type										
Package		SOP6			SOP6					
Contact form		1a(SPST-NO)			1a(SPST-NO)					
Terminal structure		Surface-mounting Terminals			Surface-mounting Terminals					
Absolute maximum Rating		Symbol	Unit	Rating		Rating				
Input	LED forward current	$I_F$	mA	30		30				
	LED reverse voltage	$V_R$	V	5		6				
Output	Load Voltage(AC/DC)	$V_{OFF}$	V	60		60				
	Continuous load current	Connection A	$I_O$	A	3.3		4			
		Connection B			6.6		8			
Connection C										
Dielectric strength between input and output		$V_{I-O}$	Vrms	1,500		1,500				
Operating Temperature		$T_a$	°C	-40 ~ + 85		-40 ~ + 110				
Storage Temperature		$T_{stg}$	°C	-55 ~ + 125		-55 ~ + 125				
Electrical Characteristics		Symbol	Unit	Min.	Typ.	Max	Min.	Typ.	Max	
Input	LED Forward voltage	$V_F$	V	1.18	1.33	1.48	1.5	1.65	1.8	
	Trigger LED Forward Current	$I_{FT}$	mA	-	0.2	3	-	0.3	3	
	Release LED Forward Current	$I_{FC}$	mA	0.1	-	-	0.1	-	-	
Output	Maximum resistance with output ON	Connection A	$R_{ON}$	$\Omega$	-	0.03	0.06	-	0.028	0.04
		Connection B			-	0.015	-	-	0.014	0.02
		Connection C			-	0.008	-	-	0.007	0.01
Current leakage when the relay is open		$I_{LEAK}$	nA	-	-	20	-	-	1000	
Capacitance between terminals		$C_{OFF}$	pF	-	700	1500	-	750	-	
Capacitance between I/O terminals		$C_{I-O}$	pF	-	0.8	-	-	0.8	-	
Insulation resistance between I/O terminals		$R_{I-O}$	M $\Omega$	1000	1.00E+08	-	1000	1.00E+08	-	
Turn-ON time		$t_{ON}$	ms	-	0.6	5	-	0.6	2	
Turn-OFF time		$t_{OFF}$	ms	-	0.2	1	-	0.15	0.5	
Approved standards		UL			UL					
Dimensions										
Terminal arrangement /Internal connections		<p>TOP VIEW</p> 			<p>TOP VIEW</p> 					

[ Characteristics / Operation ratings ]

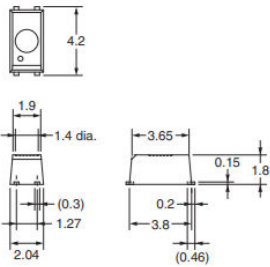
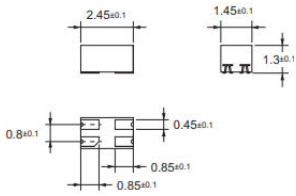
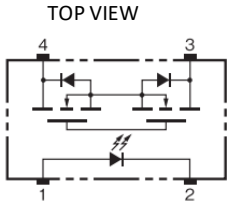
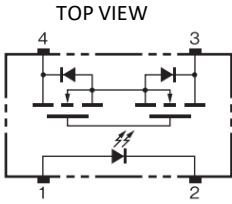
Item		Product Discontinuation				Recommended Replacement			
		G3VM-61LR G3VM-61LR(TR05)				G3VM-61UR G3VM-61UR(TR05)			
Type									
Package		SSOP4				VSON4			
Contact form		1a(SPST-NO)				1a(SPST-NO)			
Terminal structure		Surface-mounting Terminals				Surface-mounting Terminals			
Absolute maximum Rating		Symbol	Unit	Rating			Rating		
Input	LED forward current	$I_F$	mA	50			30		
	LED reverse voltage	$V_R$	V	5			5		
Output	Load Voltage(AC/DC)	$V_{OFF}$	V	60			60		
	Continuous load current	$I_O$	mA	400			400		
Dielectric strength between input and output		$V_{LO}$	Vrms	1,500			500		
Operating Temperature		$T_a$	°C	-20	~	+ 85	-40	~	+ 110
Storage Temperature		$T_{stg}$	°C	-40	~	+ 125	-40	~	+ 125
Electrical Characteristics		Symbol	Unit	Min.	Typ.	Max	Min.	Typ.	Max
Input	LED Forward voltage	$V_F$	V	1	1.15	1.3	1.1	1.22	1.4
	Trigger LED Forward Current	$I_{FT}$	mA	-	2	5	-	-	3
	Release LED Forward Current	$I_{FC}$	mA	0.2	-	-	0.1	-	-
Output	Maximum resistance with output ON	$R_{ON}$	$\Omega$	-	1	1.5	-	1	1.5
	Current leakage when the relay is open	$I_{LEAK}$	nA	-	-	1000	-	-	1
	Capacitance between terminals	$C_{OFF}$	pF	-	20	30	-	20	-
Capacitance between I/O terminals		$C_{LO}$	pF	-	0.3	-	-	1	-
Insulation resistance between I/O terminals		$R_{LO}$	M $\Omega$	1000	1.00E+08	-	1000	1.00E+08	-
Turn-ON time		$t_{ON}$	ms	-	0.3	1	-	-	0.5
Turn-OFF time		$t_{OFF}$	ms	-	0.2	1	-	-	0.5
Approved standards		UL				-			
Dimensions									
Terminal arrangement /Internal connections									

[ Characteristics / Operation ratings ]

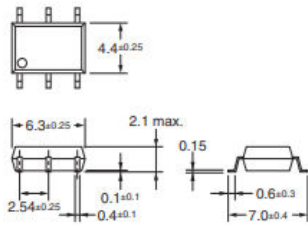
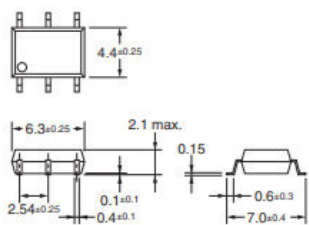
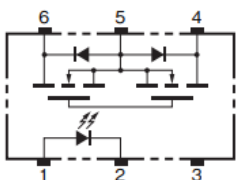
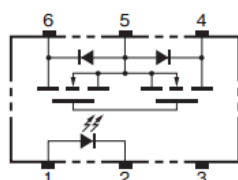
Item			Product Discontinuation			Recommended Replacement				
			G3VM-81HR G3VM-81HR(TR)			G3VM-101HR2 G3VM-101HR2(TR)				
Type										
Package			SOP6			SOP6				
Contact form			1a(SPST-NO)			1a(SPST-NO)				
Terminal structure			Surface-mounting Terminals			Surface-mounting Terminals				
Absolute maximum Rating			Symbol	Unit	Rating		Rating			
Input	LED forward current		$I_F$	mA	50		30			
	LED reverse voltage		$V_R$	V	5		6			
Output	Load Voltage(AC/DC)		$V_{OFF}$	V	80		100			
	Continuous load current	Connection A	$I_O$	A	1.25		3.0			
		Connection B			2.5		6			
Connection C										
Dielectric strength between input and output			$V_{LO}$	Vrms	1,500		1,500			
Operating Temperature			$T_a$	°C	-40	~	+ 85	-40	~	+ 110
Storage Temperature			$T_{stg}$	°C	-55	~	+ 125	-55	~	+ 125
Electrical Characteristics			Symbol	Unit	Min.	Typ.	Max	Min.	Typ.	Max
Input	LED Forward voltage		$V_F$	V	1	1.15	1.3	1.5	1.65	1.8
	Trigger LED Forward Current		$I_{FT}$	mA	-	2	5	-	0.35	3
	Release LED Forward Current		$I_{FC}$	mA	0.2	-	-	0.1	-	-
Output	Maximum resistance with output ON	Connection A	$R_{ON}$	$\Omega$	-	0.11	0.15	-	0.05	0.065
		Connection B			-	0.06	0.08	-	0.025	0.033
		Connection C			-	0.03	0.04	-	0.013	0.016
	Current leakage when the relay is open		$I_{LEAK}$	nA	-	1.2	1.5	-	-	1000
Capacitance between terminals		$C_{OFF}$	pF	-	460	1000	-	460	-	
Capacitance between I/O terminals		$C_{LO}$	pF	-	0.8	-	-	0.8	-	
Insulation resistance between I/O terminals		$R_{LO}$	M $\Omega$	1000	1.00E+08	-	1000	1.00E+08	-	
Turn-ON time		$t_{ON}$	ms	-	2	3	-	0.45	2	
Turn-OFF time		$t_{OFF}$	ms	-	0.7	1	-	0.1	0.5	
Approved standards			UL			UL				
Dimensions										
Terminal arrangement /Internal connections			<p>TOP VIEW</p> 			<p>TOP VIEW</p> 				

[ Characteristics / Operation ratings ]

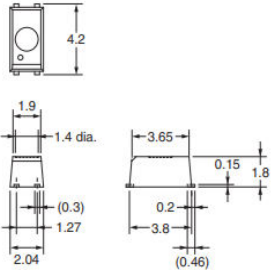
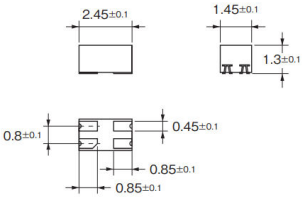
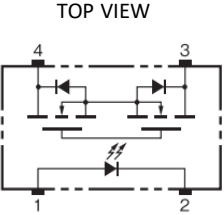
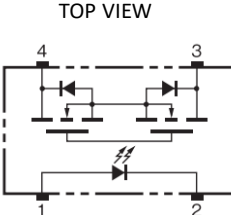
Item				Product Discontinuation			Recommended Replacement				
				G3VM-81LR G3VM-81LR(TR05)			G3VM-81UR G3VM-81UR(TR05)				
Type											
Package				SSOP4			VSON4				
Contact form				1a(SPST-NO)			1a(SPST-NO)				
Terminal structure				Surface-mounting Terminals			Surface-mounting Terminals				
Absolute maximum Rating				Symbol	Unit	Rating		Rating			
Input	LED forward current			$I_F$	mA	50		30			
	LED reverse voltage			$V_R$	V	5		5			
Output	Load Voltage(AC/DC)			$V_{OFF}$	V	80		80			
	Continuous load current			$I_O$	mA	120		120			
Dielectric strength between input and output				$V_{LO}$	Vrms	1,500		500			
Operating Temperature				$T_a$	°C	-20	~	+ 85	-40	~ + 110	
Storage Temperature				$T_{sig}$	°C	-40	~	+ 125	-40	~ + 125	
Electrical Characteristics				Symbol	Unit	Min.	Typ.	Max	Min.	Typ.	Max
Input	LED Forward voltage			$V_F$	V	1	1.15	1.3	1.1	1.22	1.4
	Trigger LED Forward Current			$I_{FT}$	mA	-	2	5	-	-	3
	Release LED Forward Current			$I_{FC}$	mA	0.1	-	-	0.1	-	-
Output	Maximum resistance with output ON			$R_{ON}$	Ω	-	7.5	12	-	7	12
	Current leakage when the relay is open			$I_{LEAK}$	nA	-	-	0.2	-	-	0.02
	Capacitance between terminals			$C_{OFF}$	pF	-	5	7	-	5	7
Capacitance between I/O terminals				$C_{LO}$	pF	-	0.8	-	-	1	-
Insulation resistance between I/O terminals				$R_{LO}$	MΩ	1000	1.00E+08	-	-	1.00E+08	-
Turn-ON time				$t_{ON}$	ms	-	0.1	0.25	-	-	0.5
Turn-OFF time				$t_{OFF}$	ms	-	0.15	0.2	-	-	0.2
Approved standards				UL			-				
Dimensions											
Terminal arrangement /Internal connections											

**[ Operation methods ]****There is no change in the operation method.**

Specifications and prices in this product news are as of the issue date and are subject to change without notice. Only main changes in specifications are described in this document. Please be sure to read the relevant catalogs, datasheets, product specifications, instructions, and manuals for precautions and necessary information when using products.

## Before change

Old part number	Old OC product code	Old ODPOS code
G3VM-101HR	G3VM1365A	G3VM101HR
G3VM-101HR(TR)	G3VM1366M	G3VM101HRTR
G3VM-101HR1	G3VM1618R	G3VM101HR1
G3VM-101HR1(TR05)	G3VM1619G	G3VM101HR1TR05
G3VM-101LR	G3VM1320A	#NV
G3VM-101LR(TR05)	G3VM1321M	G3VM101LRTR05
G3VM-21HR	G3VM1332E	G3VM21HR
G3VM-21HR(TR)	G3VM1333C	G3VM21HRTR
G3VM-21LR	G3VM1178M	#NV
G3VM-21LR(TR05)	G3VM1237M	G3VM21LRTR05
G3VM-21LR1	G3VM1180B	#NV
G3VM-21LR1(TR05)	G3VM1239F	G3VM21LR1TR05
G3VM-21LR10	G3VM1294R	#NV
G3VM-21LR10(TR05)	G3VM1293M	G3VM21LR10TR05
G3VM-21LR10(TR05)#S	G3VM1487R	#NV
G3VM-21LR11	G3VM1334A	#NV
G3VM-21LR11(TR05)	G3VM1335M	G3VM21LR11TR05
G3VM-31HR	G3VM1616B	G3VM31HR
G3VM-31HR(TR05)	G3VM1617M	G3VM31HRTR05
G3VM-41GR8	G3VM1318M	G3VM41GR8
G3VM-41GR8(TR)	G3VM1319H	G3VM41GR8TR
G3VM-41HR	G3VM1361R	G3VM41HR
G3VM-41HR(TR)	G3VM1362G	G3VM41HRTR
G3VM-41LR10	G3VM1302C	G3VM41LR10
G3VM-41LR10(TR05)	G3VM1295G	G3VM41LR10TR05
G3VM-41LR11	G3VM1303A	#NV
G3VM-41LR11(TR05)	G3VM1297C	G3VM41LR11TR05
G3VM-41LR4	G3VM1184E	#NV
G3VM-41LR4(TR05)	G3VM1247G	G3VM41LR4TR05
G3VM-41LR5	G3VM1186A	#NV
G3VM-41LR5(TR05)	G3VM1241H	G3VM41LR5TR05
G3VM-41LR6	G3VM1188H	#NV
G3VM-41LR6(TR05)	G3VM1243D	G3VM41LR6TR05
G3VM-61HR	G3VM1363E	G3VM61HR
G3VM-61HR(TR)	G3VM1364C	G3VM61HRTR
G3VM-61HR1	G3VM1522M	G3VM61HR1
G3VM-61HR1(TR05)	G3VM1523R	G3VM61HR1TR05
G3VM-61HR1(TR05)#S	G3VM1782G	#NV
G3VM-61LR	G3VM1299M	#NV
G3VM-61LR(TR05)	G3VM1300G	G3VM61LRTR05
G3VM-81HR	G3VM1224H	G3VM81HR
G3VM-81HR(TR)	G3VM1225F	G3VM81HRTR
G3VM-81LR	G3VM1315E	#NV
G3VM-81LR(TR05)	G3VM1310D	G3VM81LRTR05

\_\_\_\_\_

\_\_\_\_\_

\_\_\_\_\_

\_\_\_\_\_

\_\_\_\_\_

\_\_\_\_\_

\_\_\_\_\_

\_\_\_\_\_

\_\_\_\_\_

\_\_\_\_\_

\_\_\_\_\_

\_\_\_\_\_

## After change\*

New part number	New OC product code	New ODPOS code
G3VM-101HR2	G3VM1686C	G3VM101HR2
G3VM-101HR2(TR)	G3VM1780M	#NV
G3VM-101HR2	G3VM1686C	G3VM101HR2
G3VM-101HR2(TR05)	G3VM1687A	G3VM101HR2TR05
G3VM-101UR	G3VM1496H	#NV
G3VM-101UR(TR05)	G3VM1497F	G3VM101URTR05
G3VM-31HR1	G3VM1784C	G3VM31HR1
G3VM-31HR1(TR05)	G3VM1785A	G3VM31HR1TR05
G3VM-21UR10	G3VM1502F	G3VM21UR10
G3VM-21UR10(TR05)	G3VM1503D	G3VM21UR10TR05
G3VM-21UR1	G3VM1500M	#NV
G3VM-21UR1(TR05)	G3VM1501H	G3VM21UR1TR05
G3VM-21UR10	G3VM1502F	G3VM21UR10
G3VM-21UR10(TR05)	G3VM1503D	G3VM21UR10TR05
G3VM-21UR10(TR05)	G3VM1503D	G3VM21UR10TR05
G3VM-21UR11	G3VM1485B	#NV
G3VM-21UR11(TR05)	G3VM1486M	G3VM21UR11TR05
G3VM-31HR1	G3VM1784C	G3VM31HR1
G3VM-31HR1(TR05)	G3VM1785A	G3VM31HR1TR05
G3VM-61VR	G3VM1651M	G3VM61VR
G3VM-61VR(TR)	G3VM1840H	G3VM61VRTR
G3VM-61HR2	G3VM1786M	G3VM61HR2
G3VM-61HR2(TR05)	G3VM1787H	G3VM61HR2TR05
G3VM-41UR10	G3VM1488G	#NV
G3VM-41UR10(TR05)	G3VM1489E	G3VM41UR10TR05
G3VM-41UR11	G3VM1504B	#NV
G3VM-41UR11(TR05)	G3VM1505M	G3VM41UR11TR05
G3VM-41UR4	G3VM1829G	G3VM41UR4
G3VM-41UR4(TR05)	G3VM1830M	G3VM41UR4TR05
G3VM-41UR12	G3VM1506R	G3VM41UR12
G3VM-41UR12(TR05)	G3VM1507G	G3VM41UR12TR05
G3VM-41UR12	G3VM1506R	G3VM41UR12
G3VM-41UR12(TR05)	G3VM1507G	G3VM41UR12TR05
G3VM-61HR2	G3VM1786M	G3VM61HR2
G3VM-61HR2(TR05)	G3VM1787H	G3VM61HR2TR05
G3VM-61HR2	G3VM1786M	G3VM61HR2
G3VM-61HR2(TR05)	G3VM1787H	G3VM61HR2TR05
G3VM-61HR2(TR05)	G3VM1787H	G3VM61HR2TR05
G3VM-61UR	G3VM1492E	#NV
G3VM-61UR(TR05)	G3VM1493C	G3VM61URTR05
G3VM-101HR2	G3VM1686C	G3VM101HR2
G3VM-101HR2(TR)	G3VM1780M	#NV
G3VM-81UR	G3VM1494A	#NV
G3VM-81UR(TR05)	G3VM1495M	G3VM81URTR05

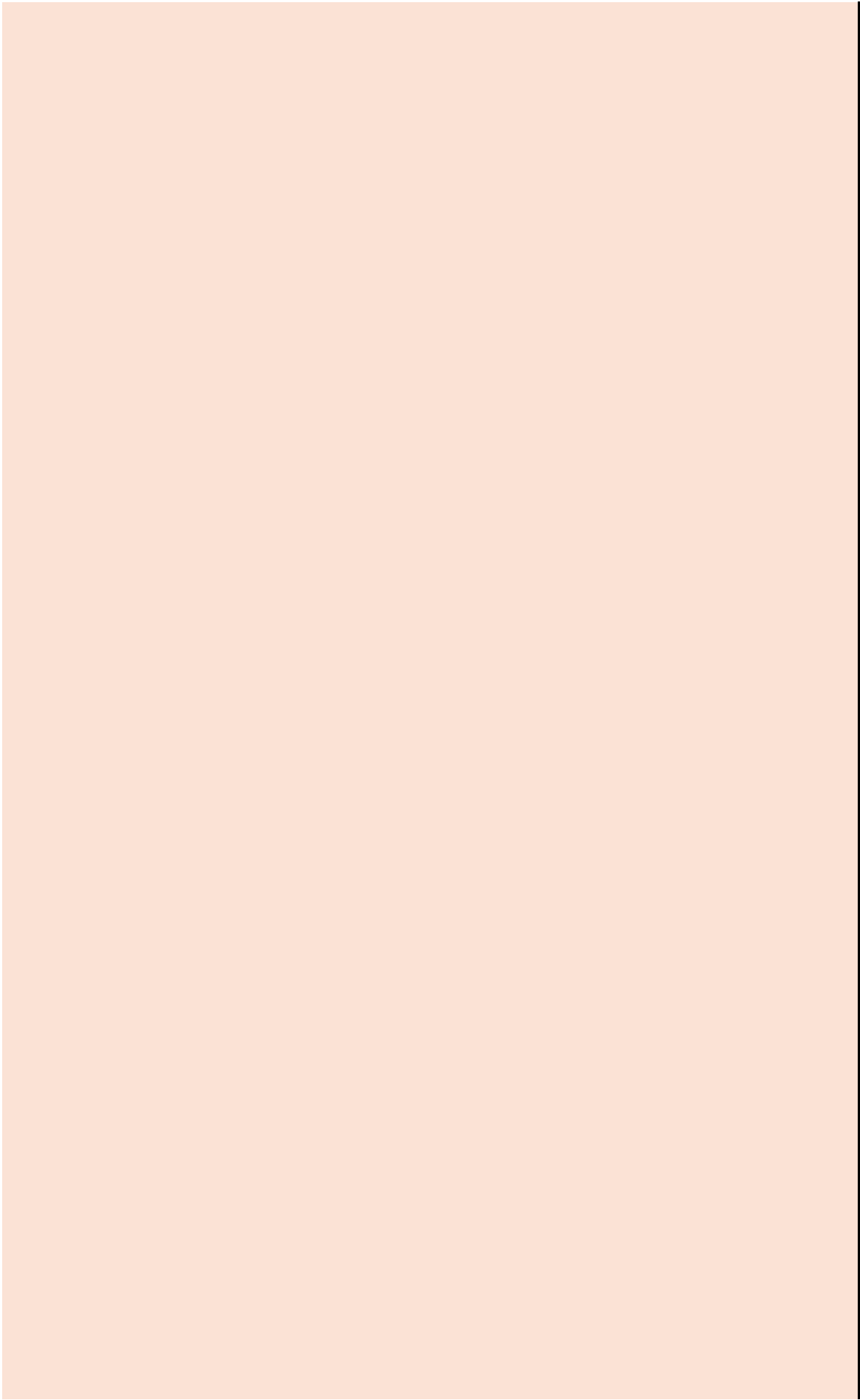

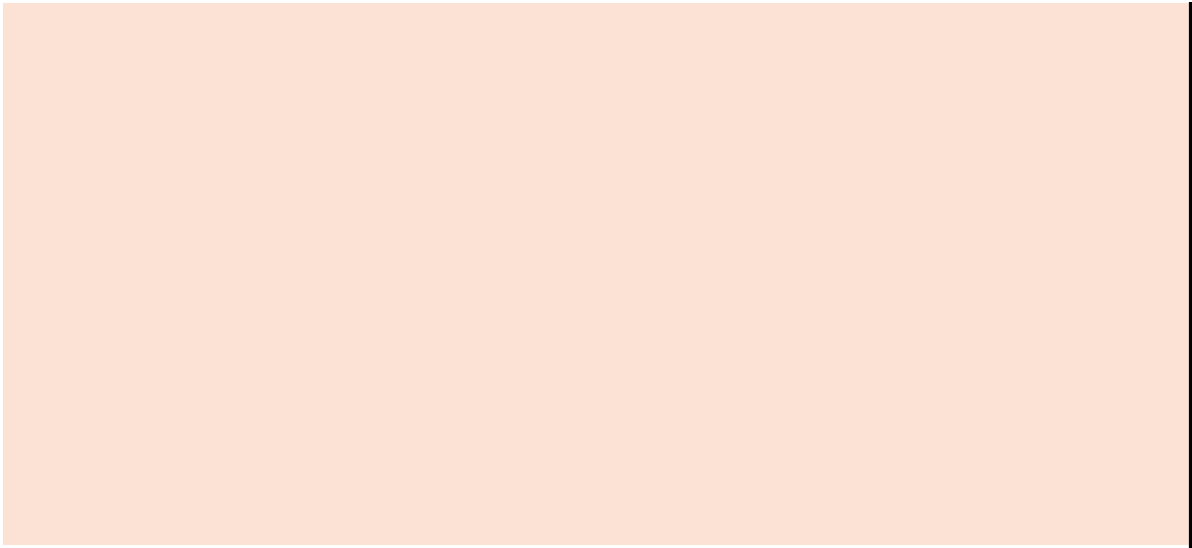

\_\_\_\_\_

\_\_\_\_\_

\_\_\_\_\_

\_\_\_\_\_

\_\_\_\_\_

\_\_\_\_\_

\_\_\_\_\_

\_\_\_\_\_

\_\_\_\_\_

\_\_\_\_\_

\*If After the change values are the same, it means the product only had technical or packing change, which does not effect the product codes!

Changes are highlighted with a background colour,