

Production Change Notice (PCN)

Supplier: Pulse Electronics (YAGEO Group)

PCN Title/No.: Manufacturing location addition - PCN-202603-001

Date: March 19, 2026

Products Affected (Pulse P/N):

ANTX100P001B15163

ANTX100P001B24003

ANTX100P001BWPEN3

ANTX100P111B24003

ANTX100P111B24553

ANTX100P112B24553

ANTX100P113B24003

ANTX150P001B24003

ANTX150P011B24003

ANTX150P111B24553

ANTX150P116B08683

ANTX150P118B09153

ANTX200P001B24003

ANTX200P002B24553

ANTX230P001B24003

Summary of Change

Pulse Electronics is adding a qualified manufacturing location for the product listed above.

- Current site (continues): Pulse Suzhou, China
- New site (added): Chilisin Electronics (Vietnam) Limited Company, Vietnam
- Nature of change: Production location only. No changes to materials, drawings, processes, specifications, form/fit/function, performance, or quality requirements.

Reason for Addition

Capacity/continuity optimization and supply-chain risk reduction.

Traceability & Labeling

Products are traceable by date code and purchase order in Pulse records. No label or revision changes are introduced by this addition. Site-specific segregation/marketing can be provided upon request.

Customer Impact

- Form/Fit/Function: No impact
- Compliance/Certifications: No impact

Effectivity & Logistics

- First ship for Vietnam site: May 1st, 2026
- Inventory: Existing current-site stock will ship per FIFO, unless otherwise agreed. Multiple source shipments may occur unless site-specific segregation is requested.

Reliability / Qualification

New Manufacturing Site (Chilisin Electronics (Vietnam) Limited Company)

Pulse Electronics has qualified the added Vietnam manufacturing site per internal and customer-aligned requirements. A full reliability report is attached to this PCN as a PDF (Appendix A).

Summary highlights:

- Qualification approach: per internal qual plan (environmental, mechanical, and functional).
- Standards referenced: JEDEC/AEC and internal Pulse procedures where applicable.
- Result: PASS — no deviations from product specifications vs. current site.

Test	Conditions	Result
Cold Storage	Room→-40°C (≤2 h), -40°C 16 h, return to room (≤2 h)	PASS
Dry Heat Storage	Room→+85°C (≤2 h), +85°C 16 h, return (≤2 h)	PASS

Damp Heat Cyclic	+95%RH @ +25°C (12 h) / +55°C (12 h), 6 cycles	PASS
Temperature Cycling	-40 ↔ +85°C with dwells and ramps, 5 cycles	PASS
Thermal Shock	+65°C / -35°C, 50 min/cycle, 20 cycles	PASS
Salt Mist	5% NaCl spray, 24 h, +35°C, +95%RH	PASS
Random Vibration	3 planes, 3×15 min (45 min total); specified PSD	PASS
Drop Test	1 corner, 3 edges, 6 flats; 1 m	PASS

Attachments - Reliability & FAI Documentation

Appendix A: Reliability Test Report - SH-HS-ETR-2602020 (Date: 2026-02-27) - Source: Pulse (Suzhou) Wireless Products Co., LTD



Reliability Test
Report SH-HS-ETR-26

Appendix B: FAI Data Sheet - Part: ANTX100P001B15163/ANTX100P001B24003/ANTX100P001BWPEN3

ANTX100P111B24003/ANTX100P111B24553/ANTX100P112B24553/ANTX100P113B24003

ANTX150P001B24003/ANTX150P011B24003/ANTX150P111B24553/ANTX150P116B08683

ANTX150P118B09153/ANTX200P001B24003/ANTX200P002B24553/ANTX230P001B24003;

Supplier: Pulse (Suzhou); Date: 2026-03-13



FAI series report.pdf

Contact Information

Lucia Zhang
QA Engineer Magnetics
Lucia.Zhang@yageo.com

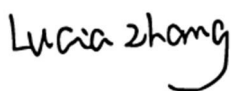

Reliability Test Report

Report No.: SH-HS-ETR-2602020

Date:2026/03/06

The Following samples were submitted and identified on behalf of the client as:

<u>Sample Name/样品名称</u>	ANTX100P001B15163, ANTX100P001B24003 ANTX100P001BWPEN3, ANTX100P111B24003, ANTX100P111B24553 ANTX100P112B24553, ANTX100P113B24003, ANTX150P001B24003, ANTX150P111B24003, ANTX150P111B24553, ANTX150P116B08683, ANTX150P118B09153, ANTX200P001B24003, ANTX200P002B24553, ANTX230P001B24003																																										
<u>Sample Quantity/样品数量</u>	:																																										
<u>Date Production/生产日期</u>	: NA																																										
<u>Date Submitted/申请日期</u>	: 2026.02.27																																										
<u>Test Period Temperature & Humidity /测试周期及温湿度</u>	: 2026.02.28 -----2025.03.06																																										
<u>Test Request/测试要求</u>	<table border="1"> <thead> <tr> <th>测试条件</th> <th>样品编号</th> <th>设备编号/校验日期</th> <th>数量</th> </tr> </thead> <tbody> <tr> <td>1. Cold Storage test 冷藏测试</td> <td>NA</td> <td>PKO-0136/2025.11.17</td> <td></td> </tr> <tr> <td>2. Dry Heat Storage test 热储存测试</td> <td>NA</td> <td>ATO180721-003/ 2025.09.26</td> <td></td> </tr> <tr> <td>3. Damp Heat Cyclic test 湿热循环测试</td> <td>NA</td> <td>192032/2025.11.17</td> <td></td> </tr> <tr> <td>4. TemperatureCycling test 温度周期变化</td> <td>NA</td> <td>PKO-0136/2025.11.17</td> <td></td> </tr> <tr> <td>5. Thermal shock test 冷热冲击试验</td> <td>NA</td> <td>ATO180721-004/2025.05.12</td> <td></td> </tr> <tr> <td>6. Salt mist test 盐雾测试</td> <td>NA</td> <td>H050310030/ 2025.11.17</td> <td></td> </tr> <tr> <td>7. Random vibration test 随机振动</td> <td>NA</td> <td>D0807194/2025.05.12</td> <td></td> </tr> <tr> <td>8. Drop test 跌落试验</td> <td>NA</td> <td>NA</td> <td></td> </tr> <tr> <td></td> <td></td> <td></td> <td></td> </tr> </tbody> </table>			测试条件	样品编号	设备编号/校验日期	数量	1. Cold Storage test 冷藏测试	NA	PKO-0136/2025.11.17		2. Dry Heat Storage test 热储存测试	NA	ATO180721-003/ 2025.09.26		3. Damp Heat Cyclic test 湿热循环测试	NA	192032/2025.11.17		4. TemperatureCycling test 温度周期变化	NA	PKO-0136/2025.11.17		5. Thermal shock test 冷热冲击试验	NA	ATO180721-004/2025.05.12		6. Salt mist test 盐雾测试	NA	H050310030/ 2025.11.17		7. Random vibration test 随机振动	NA	D0807194/2025.05.12		8. Drop test 跌落试验	NA	NA					
测试条件	样品编号	设备编号/校验日期	数量																																								
1. Cold Storage test 冷藏测试	NA	PKO-0136/2025.11.17																																									
2. Dry Heat Storage test 热储存测试	NA	ATO180721-003/ 2025.09.26																																									
3. Damp Heat Cyclic test 湿热循环测试	NA	192032/2025.11.17																																									
4. TemperatureCycling test 温度周期变化	NA	PKO-0136/2025.11.17																																									
5. Thermal shock test 冷热冲击试验	NA	ATO180721-004/2025.05.12																																									
6. Salt mist test 盐雾测试	NA	H050310030/ 2025.11.17																																									
7. Random vibration test 随机振动	NA	D0807194/2025.05.12																																									
8. Drop test 跌落试验	NA	NA																																									
<u>Test Method/测试方法</u>	: Pulse Standard/普尔思标准	√																																									
	: Customer Request/客户标准																																										
<u>Test Result/测试结果</u>	: Please refer to next page.PASS																																										
<u>Conclusion/结论</u>	: PASS																																										
<u>Suggestion/建议</u>	: NA																																										

Lisa Zhang (张金玲)/QA

NA

HE HUAMING

Applicant by:

申请人 QE/ME

Tel:

联系电话

Approval by:

确认人/LAB

Reliability Test Report

Report No.: SH-HS-ETR-2602020

Date:2026/03/06

Test Result--- Cold Storage test 冷藏测试

Sample Name	ANTX100P001B15163, ANTX100P001B24003 ANTX100P001BWPEN3, ANTX100P111B24003, ANTX100P111B24553 ANTX100P112B24553, ANTX100P113B24003, ANTX150P001B24003, ANTX150P011B24003, ANTX150P111B24553, ANTX150P116B08683, ANTX150P118B09153, ANTX200P001B24003, ANTX200P002B24553, ANTX230P001B24003	
Sample No.	:	
Test Ambient	: Temperature: 22.8°C	
	: Humidity:35%RH	
Sample Reception	: Fig.1	
Test Condition Setup	1.Room Temperatureà-40 degrees within 2 hours 2.Storage for 16 hours at -40 degrees; 3.-40 degrees room temperature within 2 hours	
Test Process	: Fig.2	
Photos After Test	: Fig.3	
Test Result	: 试验后样品外观无异常，功能测试 OK。 The samples cosmetic is OK after ORT test. The RF function test was passed.	
Final Result	: OK	√
	: NG	
Confirmed by	: HE HUAMING	
Date	: 2026.02.28	

Reliability Test Report

Report No.: SH-HS-ETR-2602020

Date:2026/03/06

Fig.1: Appearance photos of the samples before test.

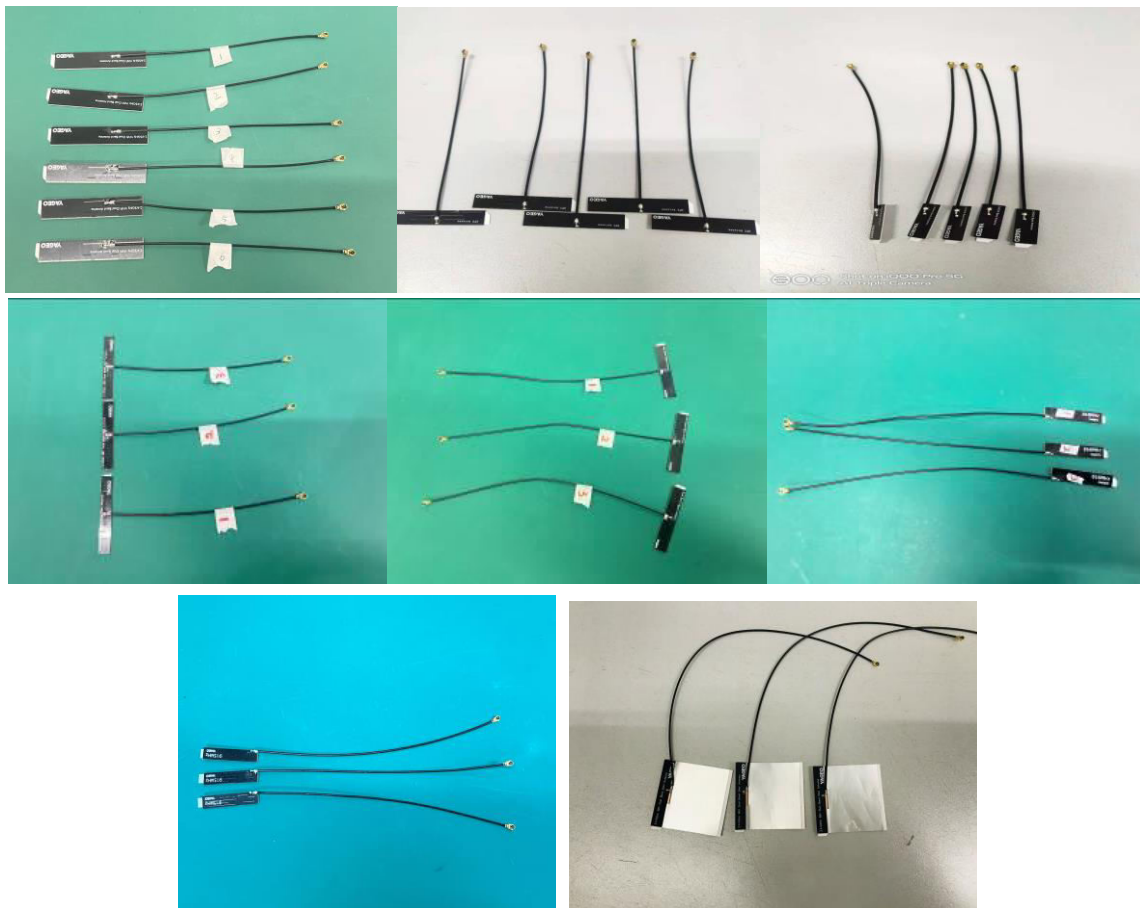

Sample No.: 2602020

Fig.2: Photo of samples in test process.(实验条件/曲线)

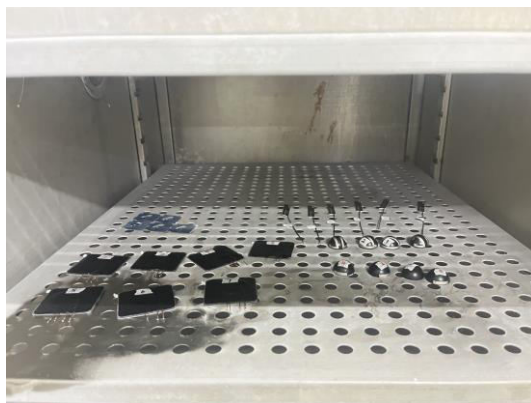

Sample No.: 2602020

Fig.3: Appearance photos of the samples after test.

Reliability Test Report

Report No.: SH-HS-ETR-2602020

Date:2026/03/06

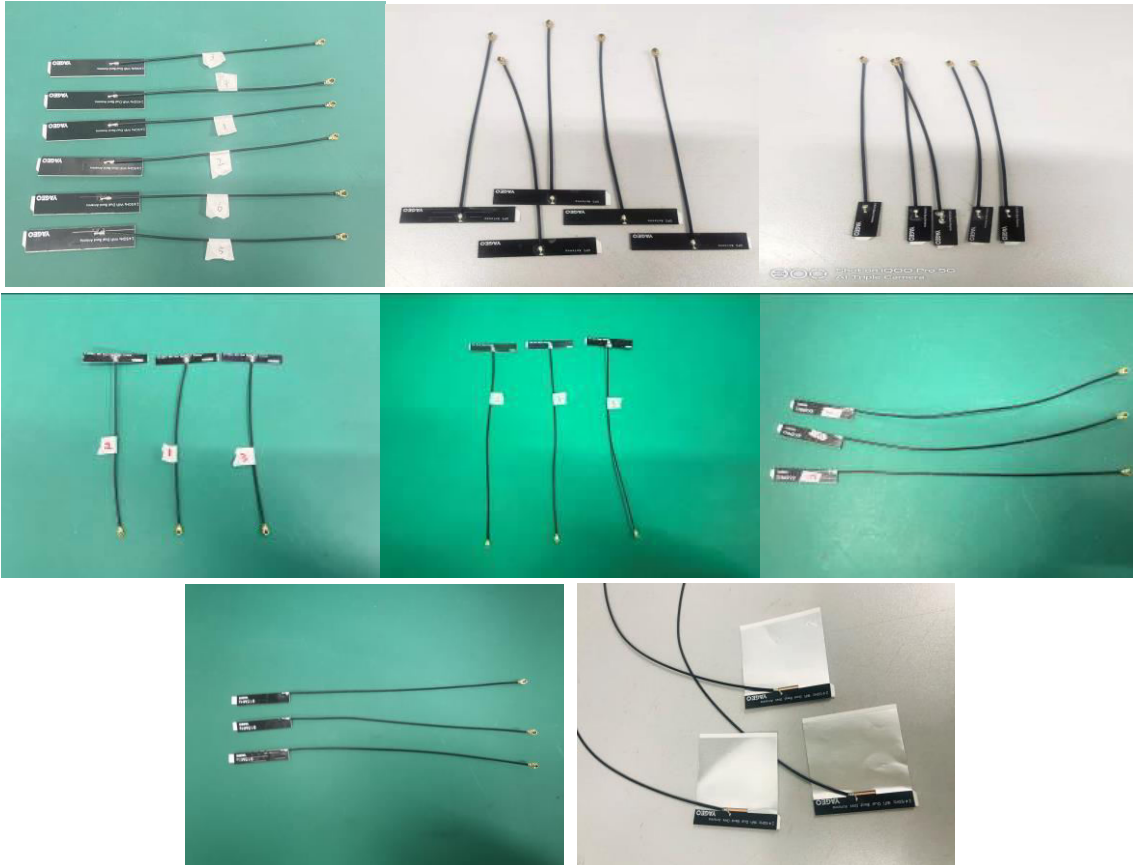

Sample No.: 2602020

.....THE END.....

Reliability Test Report

Report No.: SH-HS-ETR-2602020

Date:2026/03/06

Test Result--- Dry Heat Storage test 热储存测试

Sample Name	ANTX100P001B15163, ANTX100P001B24003 ANTX100P001BWPEN3, ANTX100P111B24003, ANTX100P111B24553 ANTX100P112B24553, ANTX100P113B24003, ANTX150P001B24003, ANTX150P011B24003, ANTX150P111B24553, ANTX150P116B08683, ANTX150P118B09153, ANTX200P001B24003, ANTX200P002B24553, ANTX230P001B24003	
Sample No.	:	
Test Ambient	: Temperature: 22.8°C	
	: Humidity:35%RH	
Sample Reception	: Fig.1	
Test Condition Setup	1.Room Temperatureà 85 degrees within 2 hours 2.Storage for 16 hours at 85 degrees; 3.85 degrees room temperature within 2 hours	
Test Process	: Fig.2	
Photos After Test	: Fig.3	
Test Result	: 试验后样品外观无异常，功能测试 OK。 The samples cosmetic is OK after ORT test. The RF function test was passed.	
Final Result	: OK	√
	: NG	
Confirmed by	: HE HUAMING	
Date	: 2026.03.03	

Reliability Test Report

Report No.: SH-HS-ETR-2602020

Date:2026/03/06

Fig.1: Appearance photos of the samples before test.

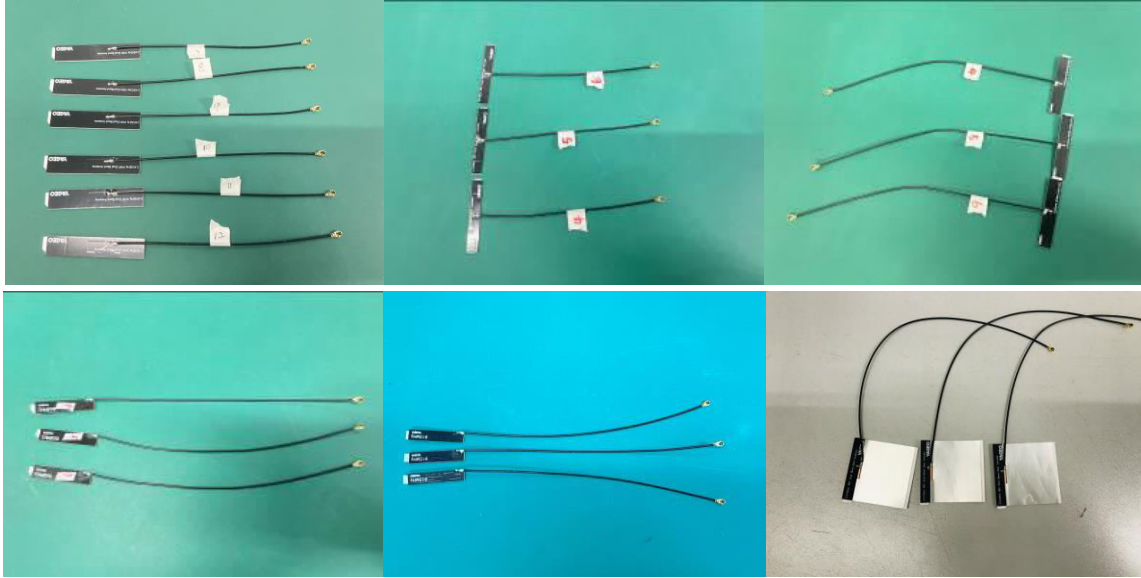

Sample No.: 2602020

Fig.2: Photo of samples in test process.(实验条件/曲线)

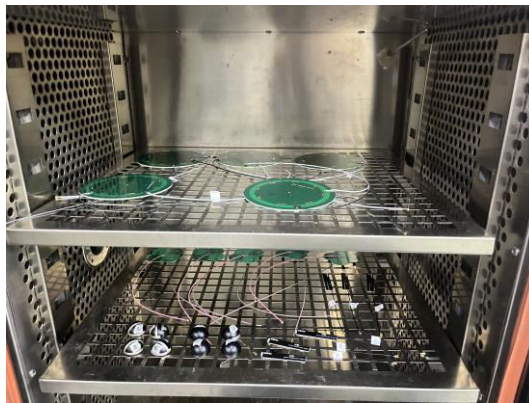

Sample No.: 2602020

Fig.3: Appearance photos of the samples after test.



Reliability Test Report

Report No.: SH-HS-ETR-2602020

Date:2026/03/06



Sample No.: 2602020
.....THE END.....

Reliability Test Report

Report No.: SH-HS-ETR-2602020

Date:2026/03/06

Test Result--- Damp Heat Cyclic test 湿热循环测试

Sample Name	ANTX100P001B15163, ANTX100P001B24003 ANTX100P001BWPEN3, ANTX100P111B24003, ANTX100P111B24553 ANTX100P112B24553, ANTX100P113B24003, ANTX150P001B24003, ANTX150P011B24003, ANTX150P111B24553, ANTX150P116B08683, ANTX150P118B09153, ANTX200P001B24003, ANTX200P002B24553, ANTX230P001B24003	
Sample No.	:	
Test Ambient	: Temperature: 22.8°C	
	: Humidity:35%RH	
Sample Reception	: Fig.1	
Test Condition Setup	: +95% RH @ +25°C for 12 h and 55°C for 12h. in 6 cycles (= 6 days)	
Test Process	: Fig.2	
Photos After Test	: Fig.3	
Test Result	: 试验后样品外观无异常，功能测试 OK。 The samples cosmetic is OK after ORT test. The RF function test was passed.	
Final Result	: OK	√
	: NG	
Confirmed by	: HE HUAMING	
Date	: 2026.03.05	

Reliability Test Report

Report No.: SH-HS-ETR-2602020

Date:2026/03/06

Fig.1: Appearance photos of the samples before test.



Sample No.: 2602020

Fig.2: Photo of samples in test process.(实验条件/曲线)



Sample No.: 2602020

Fig.3: Appearance photos of the samples after test.



Reliability Test Report

Report No.: SH-HS-ETR-2602020

Date:2026/03/06

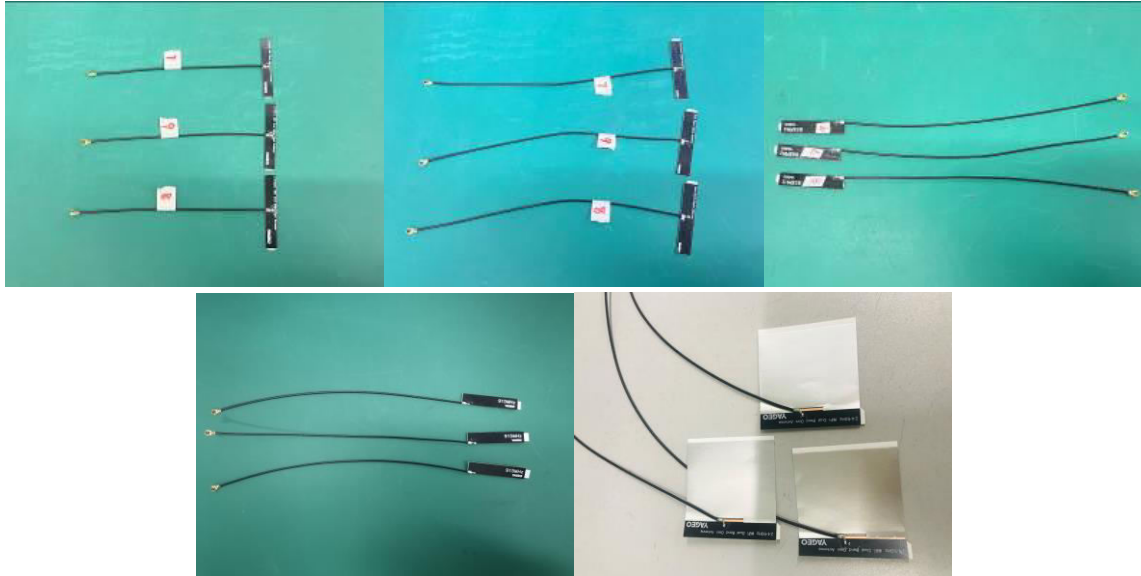

Sample No.: 2602020

.....THE END.....

Reliability Test Report

Report No.: SH-HS-ETR-2602020

Date:2026/03/06

Test Result--- Temperature Cycling test 温度周期变化

Sample Name	ANTX100P001B15163, ANTX100P001B24003 ANTX100P001BWPEN3, ANTX100P111B24003, ANTX100P111B24553 ANTX100P112B24553, ANTX100P113B24003, ANTX150P001B24003, ANTX150P011B24003, ANTX150P111B24553, ANTX150P116B08683, ANTX150P118B09153, ANTX200P001B24003, ANTX200P002B24553, ANTX230P001B24003	
Sample No.	:	
Test Ambient	: Temperature: 22.8°C	
	: Humidity:35%RH	
Sample Reception	: Fig.1	
Test Condition Setup	1.Room Temperature to -40 degrees (2hours) 2.Storage for 2 hours at -40 degrees 3.-40 degrees to 85 degrees (2hours) 4.Storage for 2 hours at 85 degrees 5.85 degrees to -40 degrees (2hours) 6.Repeat from 2 to 5 for 5 times 7.-40 degrees increase to room temperature within 2 hours	
Test Process	: Fig.2	
Photos After Test	: Fig.3	
Test Result	: 试验后样品外观无异常，功能测试 OK。 The samples cosmetic is OK after ORT test. The RF function test was passed.	
Final Result	: OK	√
	: NG	
Confirmed by	: HE HUAMING	
Date	: 2026.03.04	

Reliability Test Report

Report No.: SH-HS-ETR-2602020

Date:2026/03/06

Fig.1: Appearance photos of the samples before test.



Sample No.: 2602020

Fig.2: Photo of samples in test process.(实验条件/曲线)



Sample No.: 2602020

Fig.3: Appearance photos of the samples after test.



Sample No.: 2602020

.....THE END.....

Reliability Test Report

Report No.: SH-HS-ETR-2602020

Date:2026/03/06

Test Result--- Thermal shock test 冷热冲击试验

Sample Name	ANTX100P001B15163, ANTX100P001B24003 ANTX100P001BWPEN3, ANTX100P111B24003, ANTX100P111B24553 ANTX100P112B24553, ANTX100P113B24003, ANTX150P001B24003, ANTX150P011B24003, ANTX150P111B24553, ANTX150P116B08683, ANTX150P118B09153, ANTX200P001B24003, ANTX200P002B24553, ANTX230P001B24003	
Sample No.	:	
Test Ambient	: Temperature: 22.8°C	
	: Humidity:35%RH	
Sample Reception	: Fig.1	
Test Condition Setup	: "+65°C /-35°C, 30min (hot)/20min (cold). 50min per cycle, 20 cycles."	
Test Process	: Fig.2	
Photos After Test	: Fig.3	
Test Result	: 试验后样品外观无异常, 功能测试 OK。 The samples cosmetic is OK after ORT test. The RF function test was passed.	
Final Result	: OK	√
	: NG	
Confirmed by	: HE HUAMING	
Date	: 2026.03.02	

Reliability Test Report

Report No.: SH-HS-ETR-2602020

Date:2026/03/06

Fig.1: Appearance photos of the samples before test.



Sample No.: 2602020

Fig.2: Photo of samples in test process.(实验条件/曲线)



Sample No.: 2602020

Fig.3: Appearance photos of the samples after test.

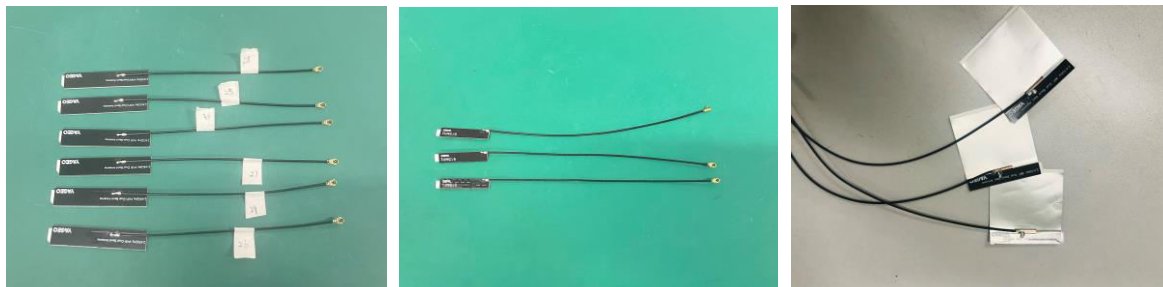

Sample No.: 2602020

.....THE END.....

Reliability Test Report

Report No.: SH-HS-ETR-2602020

Date:2026/03/06

Test Result--- Salt mist test 盐雾测试

Sample Name	ANTX100P001B15163, ANTX100P001B24003 ANTX100P001BWPEN3, ANTX100P111B24003, ANTX100P111B24553 ANTX100P112B24553, ANTX100P113B24003, ANTX150P001B24003, ANTX150P011B24003, ANTX150P111B24553, ANTX150P116B08683, ANTX150P118B09153, ANTX200P001B24003, ANTX200P002B24553, ANTX230P001B24003	
Sample No.	:	
Test Ambient	: Temperature: 22.8°C	
	: Humidity:35%RH	
Sample Reception	: Fig.1	
Test Condition Setup	5% NaCl spray for 24 h, @ +35°C,+95% RH	
Test Process	: Fig.2	
Photos After Test	: Fig.3	
Test Result	: 试验后样品外观无氧化腐蚀, 功能测试 OK。 The samples cosmetic is OK after ORT test. The RF function test was passed.	
Final Result	: OK	√
	: NG	
Confirmed by	: HE HUAMING	
Date	: 2026.02.28	

Reliability Test Report

Report No.: SH-HS-ETR-2602020

Date:2026/03/06

Fig.1: Appearance photos of the samples before test.



Sample No.: 2602020

Fig.2: Photo of samples in test process.(实验条件/曲线)



Sample No.: 2602020

Fig.3: Appearance photos of the samples after test.

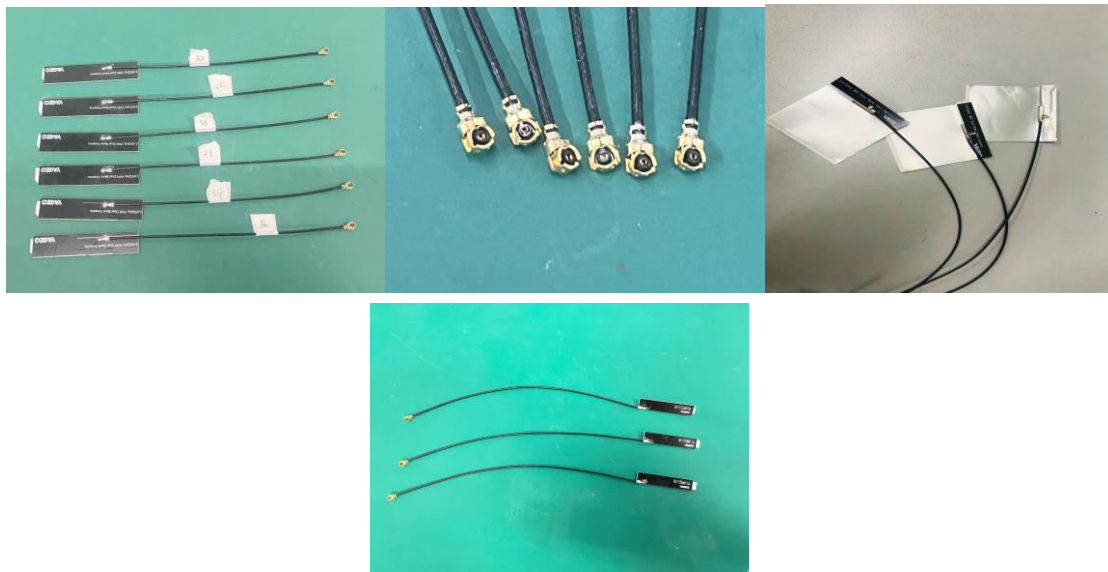

Sample No.: 2602020

.....THE END.....

Reliability Test Report

Report No.: SH-HS-ETR-2602020

Date:2026/03/06

Test Result--- Random vibration test 随机振动

Sample Name	ANTX100P001B15163, ANTX100P001B24003 ANTX100P001BWPEN3, ANTX100P111B24003, ANTX100P111B24553 ANTX100P112B24553, ANTX100P113B24003, ANTX150P001B24003, ANTX150P011B24003, ANTX150P111B24553, ANTX150P116B08683, ANTX150P118B09153, ANTX200P001B24003, ANTX200P002B24553, ANTX230P001B24003	
Sample No.	:	
Test Ambient	: Temperature: 22.8°C	
	: Humidity:35%RH	
Sample Reception	: Fig.1	
Test Condition Setup	duration 3x15 minutes 3 planes, total 45 minutes. Crossover point(Hz)频率 Level(g2/Hz)加速度 8 0.001 20 0.01 40 0.001 80 0.001 120 0.00001	
Test Process	: Fig.2	
Photos After Test	: Fig.3	
Test Result	: 试验后样品未出现起翘脱落等现象. The samples cosmetic is OK after ORT test. The RF function test was passed.	
Final Result	: OK	√
	: NG	
Confirmed by	: HE HUAMING	
Date	: 2026.03.06	

Reliability Test Report

Report No.: SH-HS-ETR-2602020

Date:2026/03/06

Fig.1: Appearance photos of the samples before test.

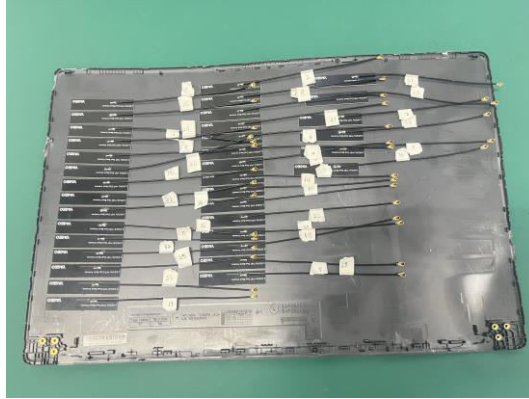

Sample No.: 2602020

Fig.2: Photo of samples in test process.(实验条件/曲线)

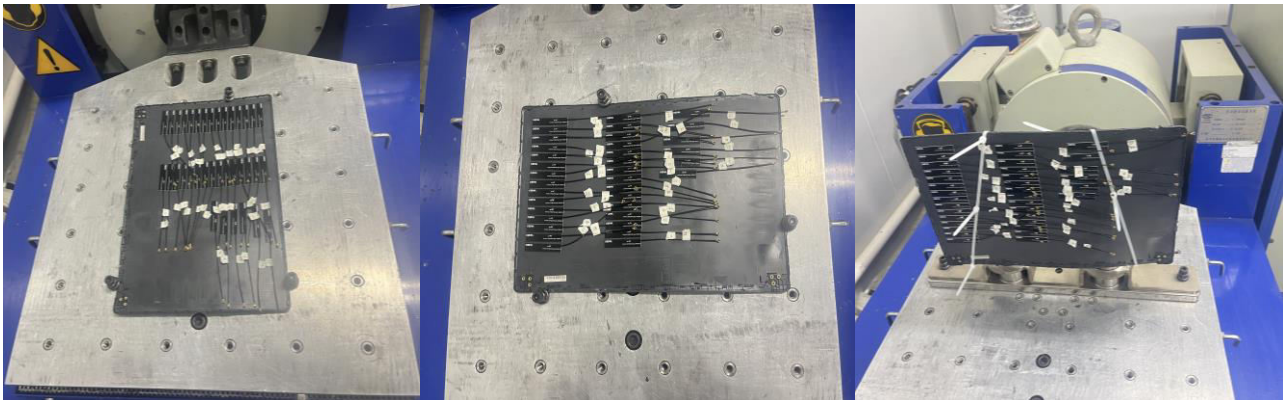

Sample No.: 2602020

Fig.3: Appearance photos of the samples after test.

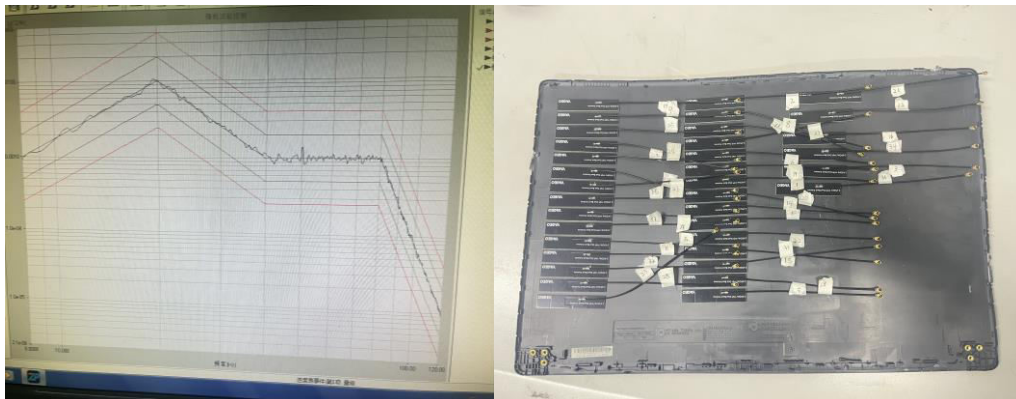

Sample No.: 2602020

.....THE END.....

Reliability Test Report

Report No.: SH-HS-ETR-2602020

Date:2026/03/06

Test Result--- Drop test 跌落试验

Sample Name	ANTX100P001B15163, ANTX100P001B24003 ANTX100P001BWPEN3, ANTX100P111B24003, ANTX100P111B24553 ANTX100P112B24553, ANTX100P113B24003, ANTX150P001B24003, ANTX150P011B24003, ANTX150P111B24553, ANTX150P116B08683, ANTX150P118B09153, ANTX200P001B24003, ANTX200P002B24553, ANTX230P001B24003	
Sample No.	:	
Test Ambient	: Temperature: 22.8°C	
	: Humidity:35%RH	
Sample Reception	: Fig.1	
Test Condition Setup	1 corner, 3 edges, 6 flats H:1M	
Test Process	: Fig.2	
Photos After Test	: Fig.3	
Test Result	: 试验后样品未出现起翘脱落等现象. No peel off defect after ORT test. The result is PASS.	
Final Result	: OK	√
	: NG	
Confirmed by	: HE HUAMING	
Date	: 2026.03.06	

Reliability Test Report

Report No.: SH-HS-ETR-2602020

Date:2026/03/06

Fig.1: Appearance photos of the samples before test.



Sample No.: 2602020

Fig.2: Photo of samples in test process.(实验条件/曲线)

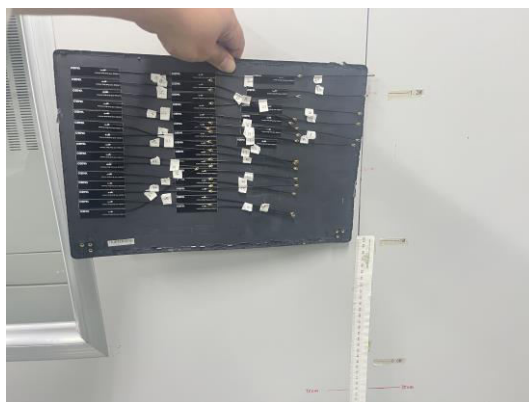

Sample No.: 2602020

Fig.3: Appearance photos of the samples after test.



Sample No.: 2602020

.....THE END.....

- Instructions:
1. Supplier have to fillout the yellow color area.
 2. The table will automatically calculate the data in white area.
 3. Any Alter or Rej Item should be attached CPK data for analysis.

FAI DATA SHEET

Part Number : ANTX100P001B15163					Supplier : Pulse (Suzhou)					Date: 2026-03-13					New:				
Part Description : ANTX100P001B15163					ISR No :					Cavity / Tool # : NA					Revised:				
Revision : 1					Material Spec: NA					Inspector: Chen Lu					Resubmission:				
CMM = Coordinate Measuring Machine, OMM = Optical Coordinate Measuring Machine, HT = Hardness Trester, TG = Thickness Gauge, VIS = Visual, PG = Plug Gauge, OTHER:																			
DRAWING SPECIFICATIONS					INSPECTION RESULTS								INSPECTION ANALYSIS				Supplier Remarks	RD Engineering Disposition	SQE Engineering Disposition
ITEM	Location	NOMINAL	+TOL	-TOL	Inspection Method	Sample Number			% Tolerance				Alert/Rej						
						1	2	3	1	2	3	Mean	UPPER	LOWER	HIGH	LOW			
1		100.00	3.000	3.000	Ruler	100.05	100	100	0.050	0.000	0.000	100.017	2%	0%					
2		40.00	0.300	0.300	Caplier	40.03	40.02	40	0.030	0.020	0.000	40.017	10%	0%					
3		7.50	0.300	0.300	Caplier	7.55	7.5	7.52	0.050	0.000	0.020	7.523	17%	0%					
4		0.55	0.150	0.150	Caplier	0.5	0.55	0.52	-0.050	0.000	-0.030	0.523	0%	33%					



- Instructions:
1. Supplier have to fillout the yellow color area.
 2. The table will automatically calculate the data in white area.
 3. Any Alter or Rej Item should be attached CPK data for analysis.

FAI DATA SHEET

Part Number : ANTX100P001B24003					Supplier : Pulse (Suzhou)					Date: 2026-03-13					New:				
Part Description : ANTX100P001B24003					ISR No :					Cavity / Tool # : NA					Revised:				
Revision : 1					Material Spec: NA					Inspector: Chen Lu					Resubmission:				
CMM = Coordinate Measuring Machine, OMM = Optical Coordinate Measuring Machine, HT = Hardness Trester, TG = Thickness Gauge, VIS = Visual, PG = Plug Gauge, OTHER:																			
DRAWING SPECIFICATIONS					INSPECTION RESULTS								INSPECTION ANALYSIS				Supplier Remarks	RD Engineering Disposition	SQE Engineering Disposition
ITEM	Location	NOMINAL	+TOL	-TOL	Inspection Method	Sample Number			% Tolerance				Alert/Rej						
						1	2	3	1	2	3	Mean	UPPER	LOWER	HIGH	LOW			
1		100.00	3.000	3.000	Ruler	100.05	100.05	100	0.050	0.050	0.000	100.033	2%	0%					
2		18.40	0.300	0.300	Caplier	18.42	18.4	18.45	0.020	0.000	0.050	18.423	17%	0%					
3		7.50	0.300	0.300	Caplier	7.52	7.53	7.52	0.020	0.030	0.020	7.523	10%	0%					
4		0.55	0.150	0.150	Caplier	0.53	0.55	0.52	-0.020	0.000	-0.030	0.533	0%	20%					



- Instructions:
1. Supplier have to fillout the yellow color area.
 2. The table will automatically calculate the data in white area.
 3. Any Alter or Rej Item should be attached CPK data for analysis.

FAI DATA SHEET

Part Number : ANTX100P001BWPEN3					Supplier : Pulse (Suzhou)					Date: 2026-03-13					New:				
Part Description : ANTX100P001BWPEN3					ISR No :					Cavity / Tool # : NA					Revised:				
Revision : 1					Material Spec: NA					Inspector: Chen Lu					Resubmission:				
CMM = Coordinate Measuring Machine, OMM = Optical Coordinate Measuring Machine, HT = Hardness Trester, TG = Thickness Gauge, VIS = Visual, PG = Plug Gauge, OTHER:																			
DRAWING SPECIFICATIONS					INSPECTION RESULTS							INSPECTION ANALYSIS				Supplier Remarks	RD Engineering Disposition	SQE Engineering Disposition	
ITEM	Location	NOMINAL	+TOL	-TOL	Inspection Method	Sample Number			% Tolerance				Alert/Rej						
						1	2	3	1	2	3	Mean	UPPER	LOWER	HIGH	LOW			
1		100.00	3.000	3.000	Ruler	100.05	100.05	100	0.050	0.050	0.000	100.033	2%	0%					
2		50.00	0.200	0.200	Caplier	50.02	50.01	50.03	0.020	0.010	0.030	50.020	15%	0%					
3		20.00	0.200	0.200	Caplier	20.05	20.03	20.02	0.050	0.030	0.020	20.033	25%	0%					
4		0.55	0.150	0.150	Caplier	0.52	0.51	0.52	-0.030	-0.040	-0.030	0.517	0%	27%					

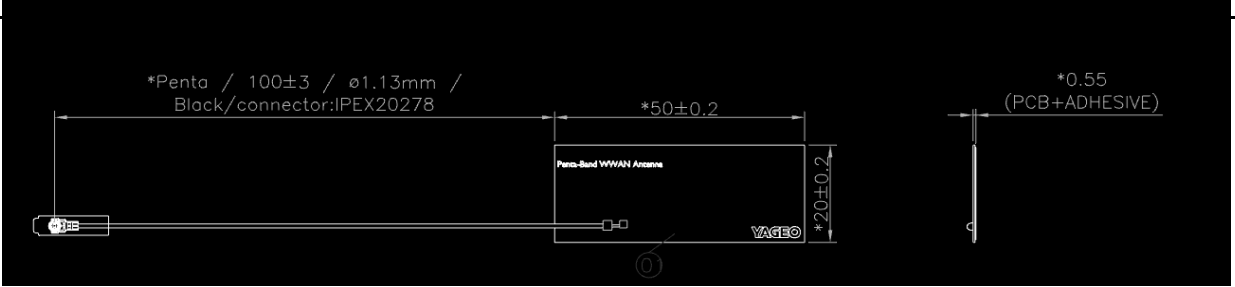

- Instructions:
1. Supplier have to fillout the yellow color area.
 2. The table will automatically calculate the data in white area.
 3. Any Alter or Rej Item should be attached CPK data for analysis.

FAI DATA SHEET

Part Number : ANTX100P111B24003	Supplier : Pulse (Suzhou)	Date: 2026-03-13	New:
Part Description : ANTX100P111B24003	ISR No :	Cavity / Tool # : NA	Revised:
Revision : 1	Material Spec: NA	Inspector: Chen Lu	Resubmission:

CMM = Coordinate Measuring Machine, OMM = Optical Coordinate Measuring Machine, HT = Hardness Trester, TG = Thickness Gauge, VIS = Visual, PG = Plug Gauge,
OTHER:

DRAWING SPECIFICATIONS					INSPECTION RESULTS								INSPECTION ANALYSIS				Supplier Remarks	RD Engineering Disposition	SQE Engineering Disposition
ITEM	Location	NOMINAL	+TOL	-TOL	Inspection Method	Sample Number			% Tolerance				Alert/Rej						
						1	2	3	1	2	3	Mean	UPPER	LOWER	HIGH	LOW			
1		100.00	3.000	3.000	Ruler	100	100	100	0.000	0.000	0.000	100.000	0%	0%					
2		39.00	0.300	0.300	Caplier	39.02	39.01	39.05	0.020	0.010	0.050	39.027	17%	0%					
3		10.00	0.300	0.300	Caplier	10.02	10.03	10.02	0.020	0.030	0.020	10.023	10%	0%					
4		20.00	0.300	0.300	OMM	20.02	20.05	20.01	0.020	0.050	0.010	20.027	17%	0%					
5		0.00	2.300	0.000	Caplier	1.9	1.85	1.8	1.900	1.850	1.800	1.850	83%		Alert				
6		0.55	0.150	0.150	Caplier	0.53	0.52	0.53	-0.020	-0.030	-0.020	0.527	0%	20%					

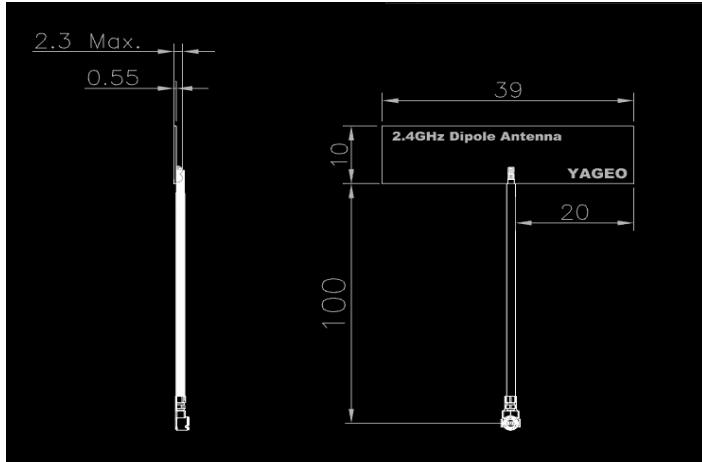

- Instructions:
1. Supplier have to fillout the yellow color area.
 2. The table will automatically calculate the data in white area.
 3. Any Alter or Rej Item should be attached CPK data for analysis.

FAI DATA SHEET

Part Number : ANTX100P111B24553					Supplier : Pulse (Suzhou)					Date: 2026-03-13					New:				
Part Description : ANTX100P111B24553					ISR No :					Cavity / Tool # : NA					Revised:				
Revision : 1					Material Spec: NA					Inspector: Chen Lu					Resubmission:				
CMM = Coordinate Measuring Machine, OMM = Optical Coordinate Measuring Machine, HT = Hardness Trester, TG = Thickness Gauge, VIS = Visual, PG = Plug Gauge, OTHER:																			
DRAWING SPECIFICATIONS					INSPECTION RESULTS								INSPECTION ANALYSIS				Supplier Remarks	RD Engineering Disposition	SQE Engineering Disposition
ITEM	Location	NOMINAL	+TOL	-TOL	Inspection Method	Sample Number			% Tolerance				Alert/Rej						
						1	2	3	1	2	3	Mean	UPPER	LOWER	HIGH	LOW			
1		100.00	3.000	3.000	Ruler	100	100	100	0.000	0.000	0.000	100.000	0%	0%					
2		40.00	0.300	0.300	Caplier	40.02	40.02	40.05	0.020	0.020	0.050	40.030	17%	0%					
3		8.00	0.300	0.300	Caplier	8.02	8.03	8.05	0.020	0.030	0.050	8.033	17%	0%					
4		0.55	0.150	0.150	Caplier	0.54	0.52	0.52	-0.010	-0.030	-0.030	0.527	0%	20%					



- Instructions:
1. Supplier have to fillout the yellow color area.
 2. The table will automatically calculate the data in white area.
 3. Any Alter or Rej Item should be attached CPK data for analysis.

FAI DATA SHEET

Part Number : ANTX100P112B24553					Supplier : Pulse (Suzhou)					Date: 2026-03-13					New:				
Part Description : ANTX100P112B24553					ISR No :					Cavity / Tool # : NA					Revised:				
Revision : 1					Material Spec: NA					Inspector: Chen Lu					Resubmission:				
CMM = Coordinate Measuring Machine, OMM = Optical Coordinate Measuring Machine, HT = Hardness Trester, TG = Thickness Gauge, VIS = Visual, PG = Plug Gauge,																			
OTHER:																			
DRAWING SPECIFICATIONS					INSPECTION RESULTS								INSPECTION ANALYSIS				Supplier Remarks	RD Engineering Disposition	SQE Engineering Disposition
ITEM	Location	NOMINAL	+TOL	-TOL	Inspection Method	Sample Number			% Tolerance				Alert/Rej						
						1	2	3	1	2	3	Mean	UPPER	LOWER	HIGH	LOW			
1		100.00	3.000	3.000	Ruler	100	100	100	0.000	0.000	0.000	100.000	0%	0%					
2		40.00	0.200	0.200	Caplier	40.02	40.02	40.05	0.020	0.020	0.050	40.030	25%	0%					
3		6.00	0.200	0.200	Caplier	6.02	6.05	6.02	0.020	0.050	0.020	6.030	25%	0%					
4		0.55	0.150	0.150	Caplier	0.53	0.53	0.52	-0.020	-0.020	-0.030	0.527	0%	20%					

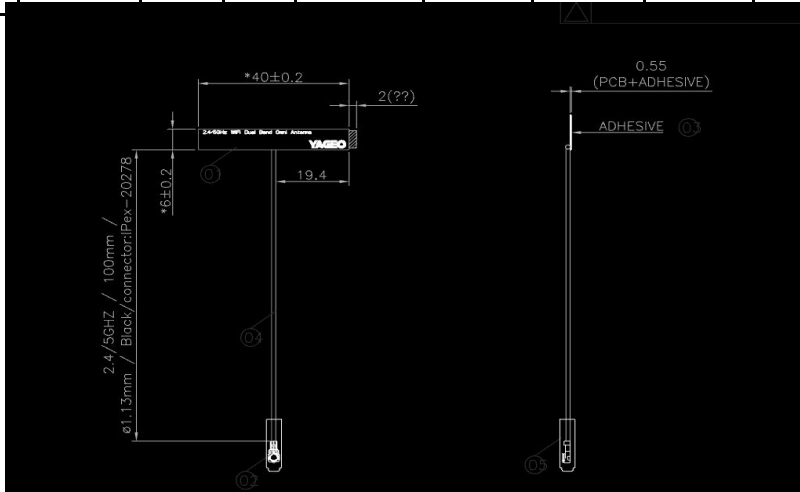

- Instructions:
1. Supplier have to fillout the yellow color area.
 2. The table will automatically calculate the data in white area.
 3. Any Alter or Rej Item should be attached CPK data for analysis.

FAI DATA SHEET

Part Number : ANTX100P113B24003					Supplier : Pulse (Suzhou)					Date: 2026-03-13					New:				
Part Description : ANTX100P113B24003					ISR No :					Cavity / Tool # : NA					Revised:				
Revision : 1					Material Spec: NA					Inspector: Chen Lu					Resubmission:				
CMM = Coordinate Measuring Machine, OMM = Optical Coordinate Measuring Machine, HT = Hardness Trester, TG = Thickness Gauge, VIS = Visual, PG = Plug Gauge,																			
OTHER:																			
DRAWING SPECIFICATIONS					INSPECTION RESULTS								INSPECTION ANALYSIS				Supplier Remarks	RD Engineering Disposition	SQE Engineering Disposition
ITEM	Location	NOMINAL	+TOL	-TOL	Inspection Method	Sample Number			% Tolerance				Alert/Rej						
						1	2	3	1	2	3	Mean	UPPER	LOWER	HIGH	LOW			
1		100.00	3.000	3.000	Ruler	100	100	100	0.000	0.000	0.000	100.000	0%	0%					
2		40.00	0.200	0.200	Caplier	40.02	40.02	40.05	0.020	0.020	0.050	40.030	25%	0%					
3		6.00	0.200	0.200	Caplier	6.02	6.05	6.02	0.020	0.050	0.020	6.030	25%	0%					
4		0.55	0.150	0.150	Caplier	0.53	0.53	0.52	-0.020	-0.020	-0.030	0.527	0%	20%					

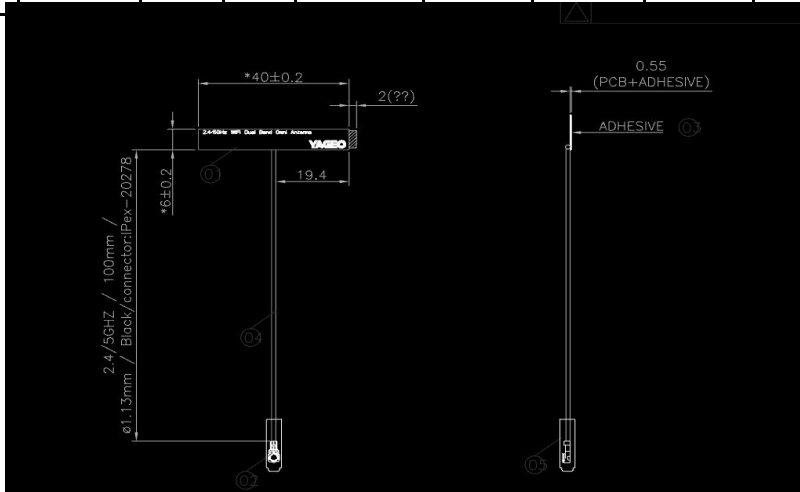

- Instructions:
1. Supplier have to fillout the yellow color area.
 2. The table will automatically calculate the data in white area.
 3. Any Alter or Rej Item should be attached CPK data for analysis.

FAI DATA SHEET

Part Number : ANTX150P001B24003					Supplier : Pulse (Suzhou)					Date: 2026-03-13					New:				
Part Description : ANTX150P001B24003					ISR No :					Cavity / Tool # : NA					Revised:				
Revision : 1					Material Spec: NA					Inspector: Chen Lu					Resubmission:				
CMM = Coordinate Measuring Machine, OMM = Optical Coordinate Measuring Machine, HT = Hardness Trester, TG = Thickness Gauge, VIS = Visual, PG = Plug Gauge, OTHER:																			
DRAWING SPECIFICATIONS					INSPECTION RESULTS								INSPECTION ANALYSIS				Supplier Remarks	RD Engineering Disposition	SQE Engineering Disposition
ITEM	Location	NOMINAL	+TOL	-TOL	Inspection Method	Sample Number			% Tolerance				Alert/Rej						
						1	2	3	1	2	3	Mean	UPPER	LOWER	HIGH	LOW			
1		150.00	3.000	3.000	Ruler	150	150.05	150	0.000	0.050	0.000	150.017	2%	0%					
2		18.40	0.300	0.300	Caplier	18.45	18.48	18.4	0.050	0.080	0.000	18.443	27%	0%					
3		7.50	0.300	0.300	Caplier	7.5	7.51	7.54	0.000	0.010	0.040	7.517	13%	0%					
4		0.55	0.150	0.150	Caplier	0.52	0.52	0.51	-0.030	-0.030	-0.040	0.517	0%	27%					

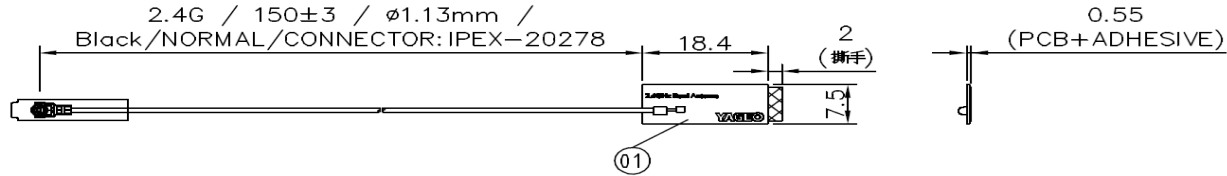

- Instructions:
1. Supplier have to fillout the yellow color area.
 2. The table will automatically calculate the data in white area.
 3. Any Alter or Rej Item should be attached CPK data for analysis.

FAI DATA SHEET

Part Number : ANTX150P011B24003					Supplier : Pulse (Suzhou)					Date: 2026-03-13					New:				
Part Description : ANTX150P011B24003					ISR No :					Cavity / Tool # : NA					Revised:				
Revision : 1					Material Spec: NA					Inspector: Chen Lu					Resubmission:				
CMM = Coordinate Measuring Machine, OMM = Optical Coordinate Measuring Machine, HT = Hardness Trester, TG = Thickness Gauge, VIS = Visual, PG = Plug Gauge, OTHER:																			
DRAWING SPECIFICATIONS					INSPECTION RESULTS								INSPECTION ANALYSIS				Supplier Remarks	RD Engineering Disposition	SQE Engineering Disposition
ITEM	Location	NOMINAL	+TOL	-TOL	Inspection Method	Sample Number			% Tolerance				Alert/Rej						
						1	2	3	1	2	3	Mean	UPPER	LOWER	HIGH	LOW			
1		150.00	3.000	3.000	Ruler	150	150	150	0.000	0.000	0.000	150.000	0%	0%					
2		39.00	0.300	0.300	Caplier	39.05	39.03	39.02	0.050	0.030	0.020	39.033	17%	0%					
3		10.00	0.300	0.300	Caplier	10.02	10.05	10.03	0.020	0.050	0.030	10.033	17%	0%					
4		0.55	0.150	0.150	Caplier	0.53	0.51	0.52	-0.020	-0.040	-0.030	0.520	0%	27%					

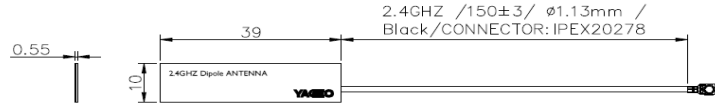

- Instructions:
1. Supplier have to fillout the yellow color area.
 2. The table will automatically calculate the data in white area.
 3. Any Alter or Rej Item should be attached CPK data for analysis.

FAI DATA SHEET

Part Number : ANTX150P111B24553					Supplier : Pulse (Suzhou)					Date: 2026-03-13					New:				
Part Description : ANTX150P111B24553					ISR No :					Cavity / Tool # : NA					Revised:				
Revision : 1					Material Spec: NA					Inspector: Chen Lu					Resubmission:				
CMM = Coordinate Measuring Machine, OMM = Optical Coordinate Measuring Machine, HT = Hardness Trester, TG = Thickness Gauge, VIS = Visual, PG = Plug Gauge, OTHER:																			
DRAWING SPECIFICATIONS					INSPECTION RESULTS								INSPECTION ANALYSIS				Supplier Remarks	RD Engineering Disposition	SQE Engineering Disposition
ITEM	Location	NOMINAL	+TOL	-TOL	Inspection Method	Sample Number			% Tolerance				Alert/Rej						
						1	2	3	1	2	3	Mean	UPPER	LOWER	HIGH	LOW			
1		150.00	3.000	3.000	Ruler	150	150	150	0.000	0.000	0.000	150.000	0%	0%					
2		40.00	0.300	0.300	Caplier	40.02	40.03	40.05	0.020	0.030	0.050	40.033	17%	0%					
3		8.00	0.300	0.300	Caplier	8.02	8.01	8.02	0.020	0.010	0.020	8.017	7%	0%					
4		0.55	0.150	0.150	Caplier	0.55	0.52	0.52	0.000	-0.030	-0.030	0.530	0%	20%					

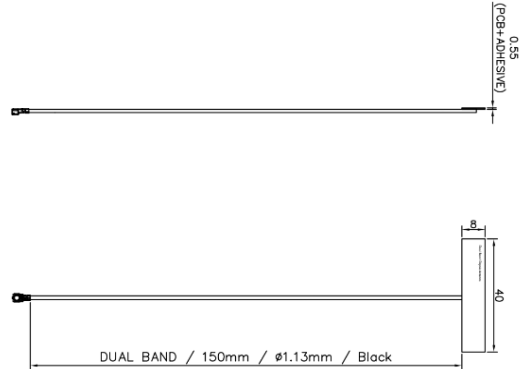

- Instructions:
1. Supplier have to fillout the yellow color area.
 2. The table will automatically calculate the data in white area.
 3. Any Alter or Rej Item should be attached CPK data for analysis.

FAI DATA SHEET

Part Number : ANTX150P116B08683					Supplier : Pulse (Suzhou)					Date: 2026-03-13					New:				
Part Description : ANTX150P116B08683					ISR No :					Cavity / Tool # : NA					Revised:				
Revision : 1					Material Spec: NA					Inspector: Chen Lu					Resubmission:				
CMM = Coordinate Measuring Machine, OMM = Optical Coordinate Measuring Machine, HT = Hardness Trester, TG = Thickness Gauge, VIS = Visual, PG = Plug Gauge, OTHER:																			
DRAWING SPECIFICATIONS					INSPECTION RESULTS								INSPECTION ANALYSIS				Supplier Remarks	RD Engineering Disposition	SQE Engineering Disposition
ITEM	Location	NOMINAL	+TOL	-TOL	Inspection Method	Sample Number			% Tolerance				Alert/Rej						
						1	2	3	1	2	3	Mean	UPPER	LOWER	HIGH	LOW			
1		150.00	2.000	2.000	Ruler	150	150	150	0.000	0.000	0.000	150.000	0%	0%					
2		34.00	0.300	0.300	Caplier	34.05	34.03	34.02	0.050	0.030	0.020	34.033	17%	0%					
3		9.00	0.300	0.300	Caplier	9.02	9.05	9.03	0.020	0.050	0.030	9.033	17%	0%					
4		0.80	0.050	0.050	Caplier	0.81	0.8	0.81											
5		0.95	0.150	0.150	Caplier	0.93	0.91	0.92	-0.020	-0.040	-0.030	0.920	0%	27%					

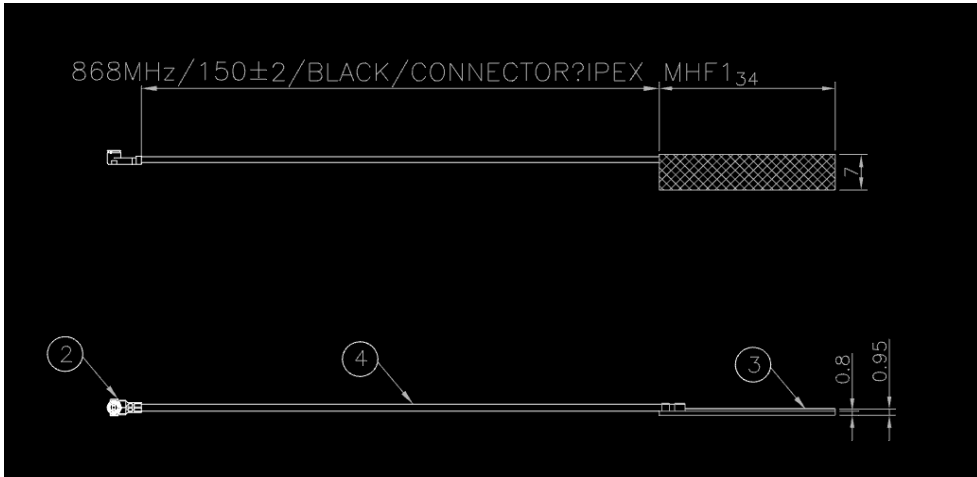

- Instructions:
1. Supplier have to fillout the yellow color area.
 2. The table will automatically calculate the data in white area.
 3. Any Alter or Rej Item should be attached CPK data for analysis.

FAI DATA SHEET

Part Number : ANTX150P118B09153					Supplier : Pulse (Suzhou)					Date: 2026-03-13					New:				
Part Description : ANTX150P118B09153					ISR No :					Cavity / Tool # : NA					Revised:				
Revision : 1					Material Spec: NA					Inspector: Chen Lu					Resubmission:				
CMM = Coordinate Measuring Machine, OMM = Optical Coordinate Measuring Machine, HT = Hardness Trester, TG = Thickness Gauge, VIS = Visual, PG = Plug Gauge,																			
OTHER:																			
DRAWING SPECIFICATIONS					INSPECTION RESULTS							INSPECTION ANALYSIS				Supplier Remarks	RD Engineering Disposition	SQE Engineering Disposition	
ITEM	Location	NOMINAL	+TOL	-TOL	Inspection Method	Sample Number			% Tolerance				Alert/Rej						
						1	2	3	1	2	3	Mean	UPPER	LOWER	HIGH	LOW			
1		150.00	3.000	3.000	Ruler	150	150	150	0.000	0.000	0.000	150.000	0%	0%					
2		34.00	0.300	0.300	Caplier	34.03	34.05	34.02	0.030	0.050	0.020	34.033	17%	0%					
3		7.00	0.300	0.300	Caplier	7.05	7.02	7.02	0.050	0.020	0.020	7.030	17%	0%					
4		0.80	0.050	0.050	Caplier	0.8	0.81	0.81											
5		0.95	0.150	0.150	Caplier	0.95	0.92	0.92	0.000	-0.030	-0.030	0.930	0%	20%					

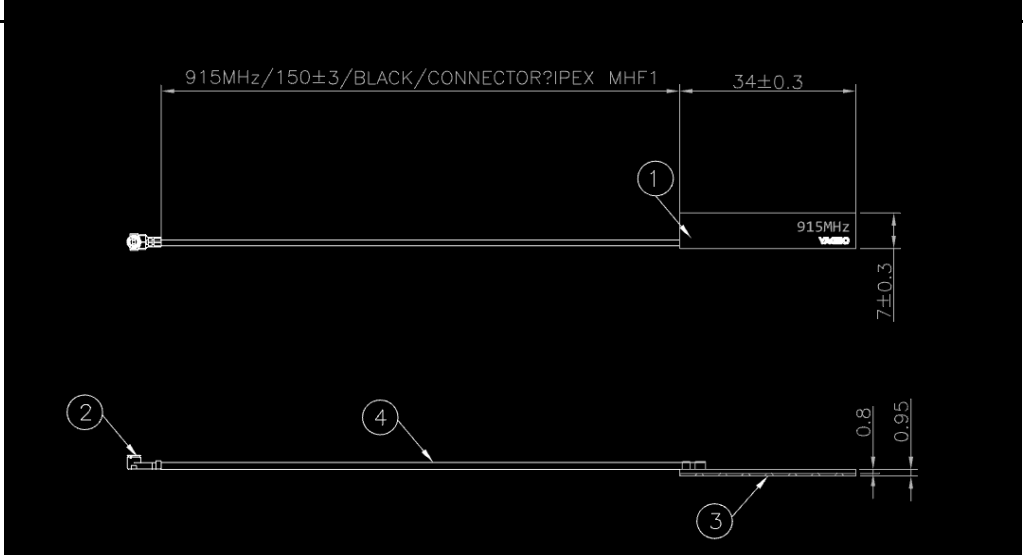

- Instructions:
1. Supplier have to fillout the yellow color area.
 2. The table will automatically calculate the data in white area.
 3. Any Alter or Rej Item should be attached CPK data for analysis.

FAI DATA SHEET

Part Number : ANTX200P001B24003					Supplier : Pulse (Suzhou)					Date: 2026-03-13					New:				
Part Description : ANTX200P001B24003					ISR No :					Cavity / Tool # : NA					Revised:				
Revision : 1					Material Spec: NA					Inspector: Chen Lu					Resubmission:				
CMM = Coordinate Measuring Machine, OMM = Optical Coordinate Measuring Machine, HT = Hardness Trester, TG = Thickness Gauge, VIS = Visual, PG = Plug Gauge, OTHER:																			
DRAWING SPECIFICATIONS					INSPECTION RESULTS								INSPECTION ANALYSIS				Supplier Remarks	RD Engineering Disposition	SQE Engineering Disposition
ITEM	Location	NOMINAL	+TOL	-TOL	Inspection Method	Sample Number			% Tolerance				Alert/Rej						
						1	2	3	1	2	3	Mean	UPPER	LOWER	HIGH	LOW			
1		200.00	3.000	3.000	Ruler	200	200	200	0.000	0.000	0.000	200.000	0%	0%					
2		18.40	0.300	0.300	Caplier	18.42	18.4	18.41	0.020	0.000	0.010	18.410	7%	0%					
3		7.50	0.300	0.300	Caplier	7.51	7.5	7.5	0.010	0.000	0.000	7.503	3%	0%					
4		0.65	0.150	0.150	Caplier	0.65	0.65	0.67	0.000	0.000	0.020	0.657	13%	0%					

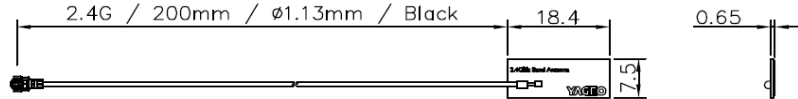

- Instructions:
1. Supplier have to fillout the yellow color area.
 2. The table will automatically calculate the data in white area.
 3. Any Alter or Rej Item should be attached CPK data for analysis.

FAI DATA SHEET

Part Number : ANTX200P002B24553					Supplier : Pulse (Suzhou)					Date: 2026-03-13					New:				
Part Description : ANTX200P002B24553					ISR No :					Cavity / Tool # : NA					Revised:				
Revision : 1					Material Spec: NA					Inspector: Chen Lu					Resubmission:				
CMM = Coordinate Measuring Machine, OMM = Optical Coordinate Measuring Machine, HT = Hardness Trester, TG = Thickness Gauge, VIS = Visual, PG = Plug Gauge, OTHER:																			
DRAWING SPECIFICATIONS					INSPECTION RESULTS								INSPECTION ANALYSIS				Supplier Remarks	RD Engineering Disposition	SQE Engineering Disposition
ITEM	Location	NOMINAL	+TOL	-TOL	Inspection Method	Sample Number			% Tolerance				Alert/Rej						
						1	2	3	1	2	3	Mean	UPPER	LOWER	HIGH	LOW			
1		200.00	3.000	3.000	Ruler	200	200	200	0.000	0.000	0.000	200.000	0%	0%					
2		40.00	0.300	0.300	Caplier	40.05	40.03	40.02	0.050	0.030	0.020	40.033	17%	0%					
3		8.00	0.300	0.300	Caplier	8.05	8.03	8.02	0.050	0.030	0.020	8.033	17%	0%					
4		0.55	0.150	0.150	Caplier	0.52	0.53	0.55	-0.030	-0.020	0.000	0.533	0%	20%					

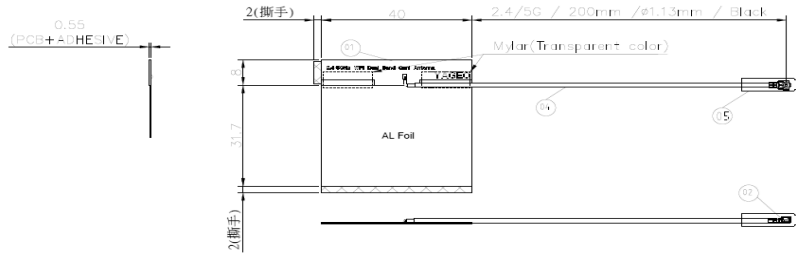

- Instructions:
1. Supplier have to fillout the yellow color area.
 2. The table will automatically calculate the data in white area.
 3. Any Alter or Rej Item should be attached CPK data for analysis.

FAI DATA SHEET

Part Number : ANTX230P001B24003					Supplier : Pulse (Suzhou)					Date: 2026-03-13					New:				
Part Description : ANTX230P001B24003					ISR No :					Cavity / Tool # : NA					Revised:				
Revision : 1					Material Spec: NA					Inspector: Chen Lu					Resubmission:				
CMM = Coordinate Measuring Machine, OMM = Optical Coordinate Measuring Machine, HT = Hardness Trester, TG = Thickness Gauge, VIS = Visual, PG = Plug Gauge, OTHER:																			
DRAWING SPECIFICATIONS					INSPECTION RESULTS							INSPECTION ANALYSIS				Supplier Remarks	RD Engineering Disposition	SQE Engineering Disposition	
ITEM	Location	NOMINAL	+TOL	-TOL	Inspection Method	Sample Number			% Tolerance				Alert/Rej						
						1	2	3	1	2	3	Mean	UPPER	LOWER	HIGH	LOW			
1		230.00	3.000	3.000	Ruler	230	230	230.05	0.000	0.000	0.050	230.017	2%	0%					
2		18.40	0.300	0.300	Caplier	18.43	18.45	18.42	0.030	0.050	0.020	18.433	17%	0%					
3		7.50	0.300	0.300	Caplier	7.51	7.52	7.51	0.010	0.020	0.010	7.513	7%	0%					
4		0.55	0.150	0.150	Caplier	0.53	0.54	0.53	-0.020	-0.010	-0.020	0.533	0%	13%					

