



PARTNER | SOLVE | DELIVER®



Reed Switches & Sensors

PRODUCT LINE BROCHURE



Standex | Smart.

Partner, Solve, Deliver® "Solving your complex problems is why we exist."



CONTENTS

- 03 About Standex
- 06 Our Capabilities
- 08 Tool Shop
- 10 Our Approach & Process
- 12 Reed Switch Technology
- 16 Reed Switch Selection Guide
- 24 Custom Sensors
- 26 Reed Sensors
- 34 Magnets
- 36 Sensor Activation Distances
- 37 Hall Effect Sensors
- 38 Fluid Sensors & Floats
- 42 Custom Fluid Level & Flow Sensors

ABOUT STANDEX

Customer Focused Engineering Solutions. “Innovating for more than 50 years.”

The Standex Electronics business, a division of Standex International Corporation (NYSE:SXI), has been providing solutions through high-performing products since the 1950's. Through growth, acquisition, strategically partnering with customers, and applying the latest engineering designs to the needs of our ever-changing world, Standex Electronics technology has been providing quality results to the end-user. The approach is achieved by partnering with customers to design and deliver individual solutions and products that truly address customers' needs.

Standex Electronics is headquartered in Cincinnati, Ohio, USA, Standex Electronics has nine manufacturing facilities in six countries, located in the United States, Germany, China, Mexico, the United Kingdom, and Japan.



That's **Standex** | Smart.

standexelectronics.com

WHO WE ARE / WHERE WE PLAY

Powerfully transforming. “When failure is not an option, designers of critical electronic components rely on Standex and their decades of experience.”

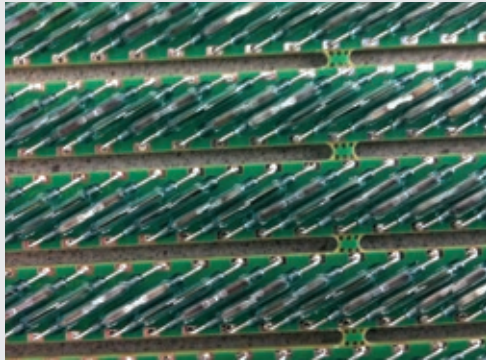

Standex Electronics is a worldwide market leader in the design, development and manufacture of reed switch and sensor solutions. Our sensor solutions include Meder, Standex and KOFU (formerly OKI) brand reed switches, as well as a complete portfolio of reed relays, and a comprehensive array of fluid level, proximity, motion, water flow, HVAC condensate,

hydraulic pressure differential, capacitive, conductive and inductive sensors. Our work, growth, and dedication to providing reliable high-quality products through our engineering and manufacturing expertise go beyond products we ship. We offer engineered product solutions for a broad spectrum of product applications in all major markets, including but not limited to:

- Aerospace & Military
- Alternative Energy
- Automotive & Transportation
- Fluid Flow
- Food Service
- General Industrial
- Heavy Duty Truck
- Household & Appliances
- HVAC / R
- Hydraulics
- Industrial & Power
- Lighting

- Medical
- Metering
- Off Highway
- Pool & Spa
- Recreational
- Security & Safety
- Space
- Test & Measurement
- Utilities & Smart Grid

Our values and what we believe align to the partner, solve, and deliver® approach. We produce parts but we are more than that. Connecting with your team as a strategic partner, listening to your challenges, and arriving at ways to solve your complex problems through our solutions are why we exist. We have custom capabilities that address your needs. Our team leverages our dynamic and diverse engineering expertise and other resources such as our global facilities for logistics and production.

50
YEARS of
INNOVATION

Standex Electronics has been innovating for over 50 years by developing new products, partnering with customers, and expanding our global capabilities. We have also grown our global reach and local touch through synergistic acquisitions.

1960 National Transistor
1969 Paul Smith Company

1971 Comtelco
1973 Underwood Electric
1974 Van Products

1998 ATR Coil /
Classic Coil Winding

2001 ATC-Frost Magnetics
2002 Cin-Tran
2003 Magnético /Trans America
2004 Lepco
2008 BG Laboratories

2012 Meder Electronic
2014 Planar Quality Corp.
2015 Northlake Engineering, Inc.®
2017 OKI Sensor Device Corp.
2018 Agile Magnetics

1960

1970

1990

2000

2010



NORTHLAKE ENGINEERING, INC.®



OUR CAPABILITIES



I A T F
16949

ISO9001
CERTIFIED

REGISTERED
AS9100

MANUFACTURING

Automated Optical Inspection (AOI)
Auto AT Switch Sorting
SMT Line with Pick & Place & Reflow
Reed Switch Manufacturing & Sensor Packaging
Wire Prep & Harness Assembly
Thermoplastic & Thermoset Overmolding
Wave & Selective Soldering
Low Pressure (Hot Melt) & Injection Molding
Potting - 2 Component
Reflow Oven – Multiple Zone Convection
Laser Welding
Plasma Surface Treatment
Stainless Steel, Metal & Plastic Fabrication
Lean Manufacturing Principles
Complete, In-House Machine Shop

ENGINEERING

3-D Magnetic Sensor Mapping
3-D CAD Modeling & 3-D Printing
Electronic sensor engineering
Circuit Design and PCB Layout
Mechanical Design & Packaging
Rapid Prototyping
Magnetic Simulation Software
Mechanical, Thermal & FEA Analysis
Plastic Mold Flow Simulation
APQP Project Management

QUALITY & COMPLIANCE

AS9100, ISO9001 & IATF16949 Certifications
ITAR Compliance
Regulatory Agency Approvals
PPAP & First Article Inspection

SPC Data Collection
RoHS, REACH, UL, ATEX & IECEx

TESTING & LAB CAPABILITIES

High Voltage/Partial Discharge Testing
Specialized Lab Testing Equipment: Network Analyzers, Nanovoltmeters, Gauss / Teslameters, Fluxmeters, Picoammeters
Reed Switch Parametric Testing
Custom Sensor Test System Design & Build
Full Load & Temperature Rise Testing
2-D/3-D Microfocus X-ray Inspection
Digital Microscopic Inspection
Burn-In & Life Testing
Thermal Shock & Temperature Cycling
Humidity, Salt Fog, & Solderability
Moisture Resistance & Seal Testing

Complete, In-House Machine Shop

“Utilizing advanced techniques in milling, wire eroding, die sinking, and grinding since 1996”

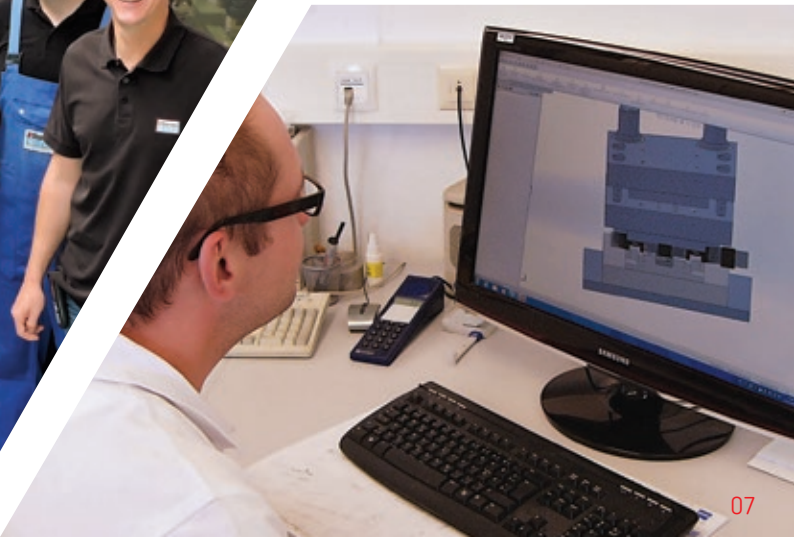

TOOL SHOP - MACHINERY, TOOLS & ASSEMBLY



Tool Shop - Machinery & Equipment, Tools & Assembly Services

Standex Electronics' tool shop was established in 1996, as a result of the growing demand for high precision quality tooling for our Reed Products as well as a means of expanding our customer service offering. Our qualified tool shop is a reliable partner providing customer support in the areas of planning, designing and constructing molding tools, punching tools and smaller pressure die-casting tools. Whether single piece or mass production tooling, a team of highly motivated and qualified employees will work with you to design

and construct the tooling that is according to your specifications as agreed upon in the form of a written quotation. The most advanced techniques will be utilized in milling, wire eroding, die sinking and grinding, as well as a select grade of steel in connection with the ideal coating will be used to guarantee that the best quality and durability is achieved for the longest life of the tool. In general, sampling, optimizing and in-house maintenance are provided for all tooling as well as first sample and failure analysis reporting.

Machinery & Equipment

- Sink EDM Machine "Exeron" -
Machining stroke max.620x420x400mm
- Sink EDM Machine "Ingersoll" -
Machining stroke max.400x400x350mm
- CNC Highspeed Milling Machine "Hermle C 30 V" -
Machining stroke max.500x450x400mm
- CNC Milling Machine "Bridgeport XR1000" -
Machining stroke max.1000x500x500mm
- Wire EDM Machine "Mitsubishi FX 10k" -
Machining stroke max.400x400x175mm
- Wire EDM Machine "Sodick ALC 400G" -
Machining stroke max.400x300x250mm
- Wire EDM Machine "Sodick AQ 537L" -
Machining stroke max.530x370x265mm
- Grinding Machine "Elb-Schliff" -
Machining stroke max.800x400x475mm
- Grinding Machine "Ziersch ZT 24" -
Machining stroke max.400x250x350mm
- Several different conventional lathe, milling and grinding machines
- Measuring machine "Zeiss Scan Max" -
Machining stroke 450x450x400mm
- Optical measuring machine "Zeiss"
- Hardness measurement machinery

Machine & Assembly Services

Stainless steel tube machining
cutting, laser welding, marking



Fixture design and production

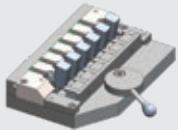

Development, design and construction



Injection Mold Tools

Design parts with high quality surfaces



Manufacturing of electrodes
in copper or graphite



Tooling repair and maintenance



CNC design, simulation, verification and integration



Optical components



Specific Tools

Die-cast zinc tools



Transfer molding tools



Stamping Tools

Progressive stamping tools
for lead frames



Technical molded parts

Gearwheels, spindles, frames and holders



Various types for prototyping, molding and stamping

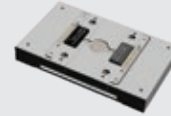

Low-pressure injection molding



Stamped parts for housing shields and contact pins



Insert molded parts



Our Approach

PARTNER // TEAMWORK

Dig deep into the customer's project and develop relationship through our thought leadership, expertise, team, and global footprint.

SOLVE // UNDERSTAND

Capabilities, lab, size, shape, power management, ranges, frequency, and more around how our capabilities can provide efficient, productive, designs & products.

DELIVER // QUALITY

Help customers win through our diverse products, dynamic capabilities, reliable high-quality magnetics solutions, and customer driven innovation and service.

Our Custom Solutions Process

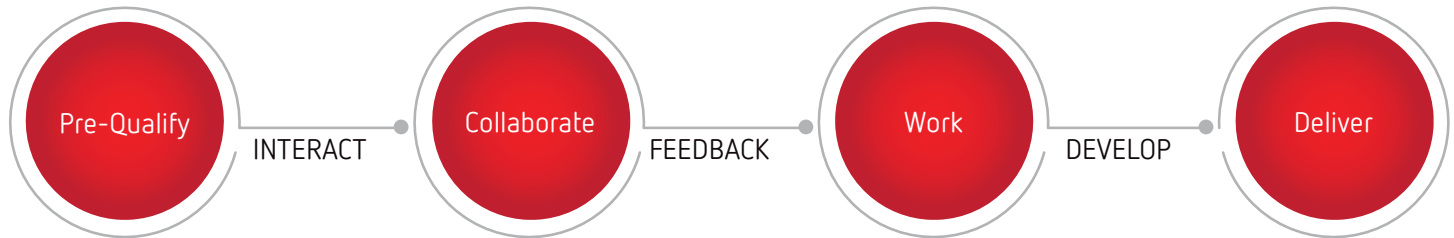

- Understand Application
- Define Design Targets
- No. of Switches
- Form (A,B,C,E)
- Max Voltage, Power, & Current
- Hot or Cold Switching
- Life Expectancy Requirements
- Isolation Requirements
- Impedence Limitations
- Temperature Range

- Certifications & Standards
- Open Engineering Team Dialogue
- Footprint, Special Pin-Outs
- Optimize Efficiency
- Electrical Modeling
- Preliminary Design Approval
- Identify Custom Components
- Creepage & Clearance Distances
- Generate Print & Quotation

- Final Design Approval
- Generate BOM
- Order Material
- Queue Samples
- Sample Build
- Test & Report
- Application Testing
- Feedback
- Repeat As Needed

- Production Order
- APQP
- FAI
- DFMEA & PFMEA
- Line Audit
- PPAP
- Delivery
- Sustaining Engineering

Complex problems deserve custom solutions - As your "application engineer experts", we select the appropriate advanced sensing technology to meet the demands of our customers. Our versatile engineering expertise in magnetic sensing technologies and custom packaging allows us to be a one-stop-shop for your sensing requirements."





3
LEADING
BRANDS

REED SWITCH TECHNOLOGY

Standex Electronics is the world's largest manufacturer of reed switches (>700M/yr) with >50% market share offering the most comprehensive listing of reed switches that cover the majority of low power switching requirements. Because reed switches are hermetically sealed (glass to metal seal) they are impervious to almost all environments. This opens up a vast number of applications where they are the only technology capable of meeting specific requirements where certain mechanical switches and semiconductor switches are environmentally limited.

Reed relays and reed sensors both use the reed switch as the heart of their switching mechanism. New applications continue to arise at a significant pace for both products because of the reed switch's unique switching capability. What is driving these new applications is the ever broadening of new reed relay, reed sensor and fluid level designs by Standex Electronics. Our solutions include KOFU (formerly OKI Sensor Device Corp.), MEDER and KENT brand reed switches...

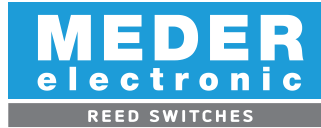

“Standex offers the most comprehensive listing of reed switches that cover the majority of low power switching requirements”

KOFU REED SWITCHES

- Largest global production volume >500M/yr
- Widest product range 7mm - 21mm
- Highest industry quality/long life
- Suitable for high-rel automotive & ATE
- Meet high voltage/breakdown requirements

MEDER REED SWITCHES

- Mechanized manufacturing in Germany
- World's smallest 3.95mm
- Unique flat blade ideal for surface mounting
- High voltage vacuum version now available

KENT REED SWITCHES

- Manufactured in the UK
- Clear glass 12.7mm - 20mm glass
- Highly automated, lowest industry cost
- Industrial grade- security, appliance, consumer



The Reed Switch was first invented by Bell Labs in the late 1930s. However, it was not until the 1940s when it began to find application widely as a sensor and a Reed Relay. Here it was used in an assortment of stepping/switching applications, early electronic equipment and test equipment. In the late 1940s Western Electric began using Reed Relays in their central office telephone switching stations, where they are still used in some areas today. The Reed Switch greatly contributed to the development of telecommunications technology.

Over the years several manufacturers have come and gone, some staying longer than they should have, tainting the marketplace with poor quality, and poor reliability. However, most of the manufacturers of Reed Switches today produce very high quality and very reliable switches. This has given rise to unprecedented growth.

Today Reed Switch technology is used in all market segments including: test and measurement equipment, medical electronics, telecom, automotive, security, appliances, general purpose, etc. Its growth rate is stronger than ever, where the world output cannot stay abreast with demand.

As a technology, the Reed Switch is unique. Being hermetically sealed, it can exist or be used in almost any environment. Very simple in its structure, it crosses many technologies in its manufacture. Critical to its quality and reliability is its glass to metal hermetic seal, where the glass and metal used must have exact linear thermal coefficients of expansion. Otherwise, cracking and poor seals will result. Whether sputtered or plated, the process of applying the contact material, usually Rhodium or Ruthenium, must be carried out precisely in ultra clean environments similar to semiconductor technology. Like semiconductors, any foreign particles present in the manufacture will give rise to losses, quality and reliability problems.

Over the years, the Reed Switch has shrunk in size from approximately 50 mm (2 inches) to 3.9 mm (0.153 inches) or less. These smaller sizes have opened up many more applications particularly in RF and fast time domain requirements.

AEC-Q200



RoHS



ELECTRICAL & MECHANICAL BENEFITS

Ability to switch up to 10,000 Volts

Ability to switch currents up to 5 Amps

Ability to switch or carry as low as 10 nanoVolts without signal loss

Ability to switch or carry as low as 1 femtoAmp without signal loss

Ability to switch or carry up to 7 GigaHz with minimal signal loss

Isolation across the contacts up to 10^{15} W

Contact resistance (on resistance) typical 50 milliOhms (mW)

In its off state it requires no power or circuitry

Ability to offer a latching feature

Operate time in the 100 ms to 300 ms range

Ability to operate at extreme temperature ranges from -55°C to 200°C

Ability to operate in all types of environments including air, water, vacuum, oil, fuels, and dust laden atmospheres

Ability to withstand shocks up to 200 G

Ability to withstand vibration environments of 50 Hz to 2000 Hz at up to 30 G

Long life with no wearing parts, load switching under 5 Volts at 10 mA, will operate well into the billions of operations

OUR PRODUCTS ARE RECOGNIZED*

Tested in accordance with AEC-Q200

In compliance with UL, CSA, EN60950, VDE, BAPT 223ZV5, ATEX & IECEx, RoHS, REACH (*not applicable to all products)

REED SWITCH SELECTION GUIDE

“Standex has the expertise and specialized equipment to ensure the highest quality during the custom reed switch manufacturing process.”



Standex Reed Switches can be customized for your design needs. Some customization includes sorting specific magnetic sensitivity pull-in ranges and cutting and/or bending the Reed contact leads for either horizontal or vertical surface mount applications or other special mounting requirements. All GR/GP, KSK and ORD Reed Switch series with normally open, normally closed or SPDT switching functions can be customized. Various different pad layouts, length of soldering pin and magnetic sensitivity class are standard options when it comes to customizing a reed switch.

In addition to these standard options, we can also customize any switch to your own design including many value add services such as PCB assembly, epoxy sealing, conformal coating, wire termination and much more. Custom switches can also be supplied in tape and reel or other desired packaging. Standex has the expertise and specialized equipment to ensure the highest quality during the custom reed switch manufacturing process.

SOLUTIONS | Reed Switches

Note: All dimensions are in mm and tolerances according to ISO 2768-m. Please refer to the product datasheets on our website for full dimensions, specifications, tolerances, etc. Not all part number combinations are possible, consult the factory for more info. We reserve the right to make any changes according to technological progress or further developments.

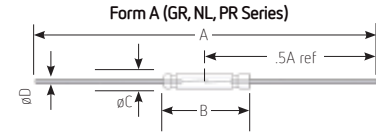
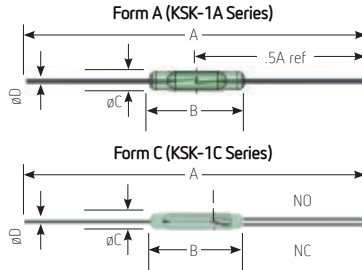
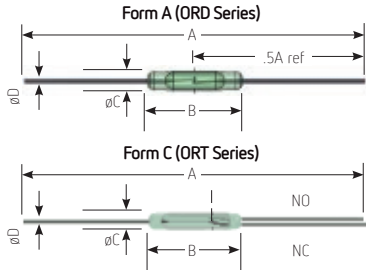
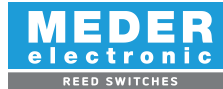

	Super Ultraminiature <8mm			Ultraminiature 9-14mm	
Reed Switch Series	KSK-1A04*	KSK-1A80*	MK23-80 (SMD)	GP400*	KSK-1A87
Description	World's Smallest Flat Lead	Long Life/Close Differential	Long Life/Close Differential	Professional Grade	Long Life
* Most Used					
Dimensions in mm (inches)					
A - Overall Length	34.5 (1.358)	35.8 (1.410)	123 (0.484)-1335 (0.525)	54 (2.125)	35.7 (1.405)
B - Glass Length Max.	3.95 (0.155)	7.0 (0.275)	7.0 (0.275)	10.0 (0.393)	10.0 (0.393)
C - Glass Dia. Max.	1.5 (0.059)	1.8 (0.070)	1.8 (0.070)	1.9 (0.075)	2.0 (0.078)
D - Lead Dia.	0.8 (0.031) x 0.15 (0.006) max	0.3 (0.011)	0.3 (0.011)	0.43 (0.017)	0.4 (0.015)
Specifications	FORM A				
Pull-In Range	5-30 AT	10-40 AT	10-40 AT	7-30 AT	10-40 AT
Rated Power Max.	3W	10W	10W	10W	10W
Switching Voltage	30VDC	170VDC	170VDC	180VDC	200VDC
Switching Current	0.3A DC	0.5A DC	0.5A DC	0.5A DC/AC	0.4A DC
Highlights					
UL Certificate NRNT2/8.E156887					

Note: All dimensions are in mm and tolerances according to ISO 2768-m. Please refer to the product datasheets on our website for full dimensions, specifications, tolerances, etc. Not all part number combinations are possible, consult the factory for more info. We reserve the right to make any changes according to technological progress or further developments.













Ultraminiature 9-14mm					
Reed Switch Series	GP400*	KSK-1A87	MK23-87 (SMD)	KSK-1A35	MK23-35 (SMD)
Description	Professional	Long Life	Long Life	Flat Lead	Flat Lead
* Most Used	Grade				
Dimensions in mm (inches)					
A - Overall Length	54 (2.125)	35.7 (1.405)	14.9 (0.586)-16.6 (0.653)	34.5 (1.358)	15.75 (0.620)-19.9 (0.775)
B - Glass Length Max.	10.0 (0.393)	10.0 (0.393)	10.0 (0.393)	10.5 (0.413)	10.5 (0.413)
C - Glass Dia. Max.	1.9 (0.075)	2.0 (0.078)	2.0 (0.078)	2.1 (0.082)	2.1 (0.082)
D - Lead Dia.	0.43 (0.017)	0.4 (0.015)	0.4 (0.015)	1.2 (0.047) x 0.2 (0.008)	1.2 (0.047) x 0.2 (0.008)
			FORM A		
Specifications	○-----○				
Pull-In Range	7-30 AT	10-40 AT	10-40 AT	10-40 AT	10-30 AT
Rated Power Max.	10W	10W	10W	20W	20W
Switching Voltage	180VDC	200VDC	200VDC	200VDC	200VDC
Switching Current	0.5A DC/AC	0.4A DC	0.4A DC	1A DC	1A DC
Highlights					
UL Certificate NRNT2/8.E156887					













Ultraminiature 9-14mm					
Reed Switch Series	KSK-1A35/1*	KSK-1A31	KSK-1A46	MK23-46 (SMD)	GR501*
Description	Mini/ Flat Lead	Miniature	Close	Close	High
* Most Used	High Voltage	Mercury	Differential	Differential	Stability
Dimensions in mm (inches)					
A - Overall Length	34.5 (1.358)	41.0 (1.614)	44.3 (1.744)	16.9 (0.665)-18.55 (0.730)	54 (2.125)
B - Glass Length Max.	10.5 (0.413)	11.0 (0.433)	12.0 (0.472)	12.0 (0.472)	12.7 (0.5)
C - Glass Dia. Max.	2.1 (0.082)	2.5 (0.098)	2.0 (0.078)	2.0 (0.078)	2.3 (0.090)
D - Lead Dia.	1.2 (0.047) x 0.2 (0.008)	0.5 (0.019)	0.5 (0.019)	0.5 (0.019)	0.45 (0.017)
			FORM A		
Specifications	○-----○				
Pull-In Range	10-40 AT	10-40 AT	10-40 AT	10-40 AT	10-35 AT
Rated Power Max.	50W	50W	10W	10W	10W
Switching Voltage	500VDC	500VDC	200VDC	200VDC	200VDC
Switching Current	2.0A DC	2.0A DC	0.5A DC	0.5A DC	0.5A DC/AC
Highlights					
UL Certificate NRNT2/8.E156887					

SOLUTIONS | Reed Switches

Note: All dimensions are in mm and tolerances according to ISO 2768-m. Please refer to the product datasheets on our website for full dimensions, specifications, tolerances, etc. Not all part number combinations are possible, consult the factory for more info. We reserve the right to make any changes according to technological progress or further developments.











MEDER electronic REED SWITCHES		Ultraminiature 9-14mm			
Reed Switch Series	KSK-1A66*	KSK-1E66	KSK-1A66/3*	MK23-66 (SMD)	KSK-1B90U*
Description	High Automotive Grade	Latching	High Performance	High-Grade Automotive	Normally Closed
* Most Used		High Automotive Grade			
Dimensions in mm (inches)					
A - Overall Length	44.3 (1.744)	44.3 (1.744)	44.3 (1.744)	188 (0.740)-20.55 (0.809)	55.1 (2.169)
B - Glass Length Max.	14.0 (0.551)	14.0 (0.551)	14.0 (0.551)	14.0 (0.551)	14.0 (0.551)
C - Glass Dia. Max.	2.2 (0.086)	2.2 (0.086)	2.2 (0.086)	2.2 (0.086)	2.54 (0.1)
D - Lead Dia.	0.5 (0.019)	0.5 (0.019)	0.5 (0.019)	0.5 (0.019)	0.5 (0.019)
Specifications	FORM A	FORM E	FORM A	FORM B	
Pull-In Range	10-40 AT	30-40 AT	10-40 AT	10-40 AT	15-45 AT
Rated Power Max.	10W	10W	10W	10W	10W
Switching Voltage	180VDC	100VDC	200VDC	180VDC	175VDC
Switching Current	0.5A DC	0.5A DC	0.5A DC	0.5A DC	0.5A DC
Highlights	 	 	 	 	 
UL Certificate	NRNT2/8.E156887				

MEDER electronic REED SWITCHES		KENT REED SWITCHES		Ultraminiature 9-14mm	
Reed Switch Series	KSK-1C90U*	KSK-1C90F	MK23-90 (SMD)	GR560*	PR560
Description	Changeover	Changeover	Changeover	High Stability	AC Line Voltage
* Most Used		NC Dog Leg Bend	NC Dog Leg Bend		
Dimensions in mm (inches)					
A - Overall Length	55.1 (2.169)	54.5 (2.145)	24.9 (0.980)-25.9 (1.019)	54 (2.125)	54 (2.125)
B - Glass Length Max.	14.0 (0.551)	14.0 (0.551)	14.0 (0.551)	14.2 (0.559)	14.2 (0.559)
C - Glass Dia. Max.	2.54 (0.1)	2.54 (0.1)	2.54 (0.1)	2.3 (0.090)	2.3 (0.090)
D - Lead Dia.	0.5 (0.019)	0.5 (0.019)	0.5 (0.019)	0.6 (0.023)	0.6 (0.023)
Specifications	FORM C	FORM C	FORM A	FORM A	
Pull-In Range	15-45 AT	15-45 AT	15-45 AT	10-50 AT	20-40 AT
Rated Power Max.	10W	10W	10W	10W	10W
Switching Voltage	175VDC	175VDC	175VDC	200VDC	100VDC/250VAC
Switching Current	0.5A DC	0.5A DC	0.5A DC	1.0A DC/AC	1.0A DC/AC
Highlights	 	 	 	 	 
UL Certificate	NRNT2/8.E156887				













Note: All dimensions are in mm and tolerances according to ISO 2768-m. Please refer to the product datasheets on our website for full dimensions, specifications, tolerances, etc. Not all part number combinations are possible, consult the factory for more info. We reserve the right to make any changes according to technological progress or further developments.



Miniature 16-21 mm					
Reed Switch Series	KSK-1A55	KSK-1A82	GR100	NL126	PR126
Description	Lamp Load	High Current	Medium Power	Lamp Load	Line Voltage
* Most Used			Professional Grade		
Dimensions in mm (inches)					
A - Overall Length	44.1 (1.736)	44.1 (1.736)	54 (2.125)	54 (2.125)	54 (2.125)
B - Glass Length Max.	16.5 (0.649)	16.5 (0.649)	20.3 (0.799)	20.3 (0.799)	20.3 (0.799)
C - Glass Dia. Max.	2.8 (0.110)	2.8 (0.110)	2.5 (0.098)	2.5 (0.098)	2.5 (0.098)
D - Lead Dia.	0.6 (0.023)	0.6 (0.023)	0.6 (0.023)	0.7 (0.027)	0.7 (0.027)
Specifications	FORM A				
Pull-In Range	15-60 AT	30-40 AT	10-40 AT	20-50 AT	20-50 AT
Rated Power Max.	50W	120W	10W	50W	70W
Switching Voltage	100VDC	150VDC	100VDC / 150VAC	200VDC / 150VAC	300VAC / 200VDC
Switching Current	0.5A DC	2.0A DC	1.0A DC	1.5A DC / AC	1.5A DC / AC
Highlights	 	 	 	 	 
UL Certificate NRNT2/8.E156887					



Miniature 16-21 mm					
Reed Switch Series	KSK-1A53	KSK-1A52	MK23-52 (SMD)	MK23-85 (SMD)	KSK-1A85
Description	High Frequency	High Breakdown Voltage	High Breakdown Voltage	Vacuum High Power	Vacuum High Power
* Most Used					
Dimensions in mm (inches)					
A - Overall Length	55 (2.165)	55.4 (2.181)	27.9 (1.098)-29.6 (1.165)	27.9 (1.098)-29.6 (1.165)	55.5 (2.185)
B - Glass Length Max.	20.5 (0.807)	21.0 (0.826)	21.0 (0.826)	21.0 (0.826)	21.0 (0.826)
C - Glass Dia. Max.	2.8 (0.110)	2.75 (0.108)	2.75 (0.108)	2.75 (0.108)	2.75 (0.108)
D - Lead Dia.	0.6 (0.023)	0.6 (0.023)	0.6 (0.023)	0.6 (0.023)	0.6 (0.023)
Specifications	FORM A				
Pull-In Range	-	15-70 AT	15-70 AT	15-55 AT	15-55 AT
Rated Power Max.	10W	50W	50W	100W	100W
Switching Voltage	200VDC	350VDC	350VDC	1,000VDC	1,000VDC
Switching Current	1.0A DC	0.5A DC	0.5A DC	1.0A DC	1.0A DC
Highlights	 	 	 	 	 
UL Certificate NRNT2/8.E156887					

SOLUTIONS | Reed Switches

Note: All dimensions are in mm and tolerances according to ISO 2768-m. Please refer to the product datasheets on our website for full dimensions, specifications, tolerances, etc. Not all part number combinations are possible, consult the factory for more info. We reserve the right to make any changes according to technological progress or further developments.



Reed Switch Series	KSK-1B85	KSK-1E85	KSK-1C10	KSK-1A33	KSK-1A83
Description	Normally Closed	Latching	High Current	High Current	High Current
* Most Used	Latching		Changeover		Flat Lead
Dimensions in mm (inches)					
A - Overall Length	55.5 (2.185)	55.5 (2.185)	86.1 (3.390)	79.0 (3.110)	81.6 (3.212)
B - Glass Length Max.	21.0 (0.826)	21.0 (0.826)	34.3 (1.350)	52.0 (2.047)	53.4 (2.102)
C - Glass Dia. Max.	2.75 (0.108)	2.75 (0.108)	5.16 (0.203)	5.4 (0.212)	5.4 (0.212)
D - Lead Dia.	0.6 (0.023)	0.6 (0.023)	1.01 (0.040)	0.5 (0.019)	2.49 (0.098) x 0.54 (0.213)
Specifications	FORM B	FORM E	FORM C	FORM A	
Pull-In Range	15-55 AT	30-55 AT	60-80 AT	80-100 AT	100-150 AT
Rated Power Max.	100W	100W	100W	50W	50W
Switching Voltage	350VDC	350VDC	500VDC	10,000VDC	7,500VDC
Switching Current	1.0A DC	1.0A DC	3.0A DC	3.0A DC	3.0A DC
Highlights					
UL Certificate NRNT2/8.E156887					



Reed Switch Series	KSK-1A69	KSK-1A54
Description	High Current	High
* Most Used	Flat Lead	Frequency
Dimensions in mm (inches)		
A - Overall Length	81.6 (3.212)	81.6 (3.212)
B - Glass Length Max.	53.4 (2.102)	53.4 (2.102)
C - Glass Dia. Max.	5.4 (0.212)	5.4 (0.212)
D - Lead Dia.	2.49 (0.098) x 0.54 (0.213)	1.3 (0.051)
Specifications	FORM A	
Pull-In Range	95-170 AT	-
Rated Power Max.	50W	25W
Switching Voltage	10,000VDC	500VDC
Switching Current	3.0A DC	1.5A DC
Highlights		
UL Certificate NRNT2/8.E156887		

Note: All dimensions are in mm and tolerances according to ISO 2768-m. Please refer to the product datasheets on our website for full dimensions, specifications, tolerances, etc. Not all part number combinations are possible, consult the factory for more info. We reserve the right to make any changes according to technological progress or further developments.



	Super Ultraminiature <8mm		Ultraminiature 9-14mm		
Reed Switch Series	ORD213*	ORD311*	ORD211*	ORD219*	ORD312*
Description					
* Most Used					
Dimensions in mm (inches)					
A - Overall Length	35.8 (1.409)	35.8 (1.409)	35.7 (1.405)	44.3 (1.744)	44.3 (1.744)
B - Glass Length Max.	7.0 (0.275)	7.0 (0.275)	10.0 (0.393)	12.0 (0.472)	12.0 (0.472)
C - Glass Dia. Max.	1.8 (0.070)	1.8 (0.070)	2.0 (0.078)	2.0 (0.078)	2.0 (0.078)
D - Lead Dia.	0.3 (0.011)	0.33 (0.013)	0.4 (0.015)	0.5 (0.019)	0.5 (0.019)
Specifications	FORM A				
Pull-In Range	10-40 AT	10-40 AT	10-40 AT	10-40 AT	10-40 AT
Rated Power Max.	1W	10W	1W	10W	30W
Switching Voltage	24VAC/DC	100VAC / DC	24VAC/DC	100VAC / DC	200VDC / 100VAC
Switching Current	0.1A DC	0.5A DC	0.1A DC	0.5A DC	0.5A DC
Highlights	KOFU	KOFU	KOFU	KOFU	KOFU
UL Certificate NRNT2.E70063					



	Ultraminiature 9-14mm				
Reed Switch Series	ORD221	ORD2221	ORD228VL*	ORD324*	ORD324H
Description	Offset	Offset	High Automotive Grade	High Performance	High Performance Long Lead
* Most Used		Long Lead			
Dimensions in mm (inches)					
A - Overall Length	44.2 (1.740)	56.7 (2.232)	44.3 (1.744)	44.3 (1.744)	56.7 (2.232)
B - Glass Length Max.	13.0 (0.512)	13.0 (0.512)	14.0 (0.551)	14.0 (0.551)	14.0 (0.551)
C - Glass Dia. Max.	2.3 (0.090)	2.3 (0.090)	2.2 (0.086)	2.2 (0.086)	2.2 (0.086)
D - Lead Dia.	0.35 (0.014) x 0.6 (0.024)	0.35 (0.014) x 0.6 (0.024)	0.5 (0.019)	0.5 (0.019)	0.5 (0.019)
Specifications	FORM A				
Pull-In Range	10-30 AT	10-30 AT	10-40 AT	10-40 AT	10-40 AT
Rated Power Max.	10W	10W	10W	10W	10W
Switching Voltage	100VAC / DC	100VAC / DC	100VAC / DC	200VDC / 150VAC	200VDC / 150VAC
Switching Current	0.3A DC	0.3A DC	0.5A DC	0.5A DC	0.5A DC
Highlights	KOFU	KOFU	KOFU	KOFU	KOFU
UL Certificate NRNT2.E70063					

SOLUTIONS | Reed Switches

Note: All dimensions are in mm and tolerances according to ISO 2768-m. Please refer to the product datasheets on our website for full dimensions, specifications, tolerances, etc. Not all part number combinations are possible, consult the factory for more info. We reserve the right to make any changes according to technological progress or further developments.



	Ultraminiature 9-14mm		Miniature 16-21mm		
Reed Switch Series	ORT551	ORT551-1	ORD2211	ORD2211H	ORD9215
Description	Changeover	Changeover	Lamp Load	Lamp Load	General Purpose Miniature
* Most Used		NC Dog Leg Bend		Long Lead	
Dimensions in mm (inches)					
A - Overall Length	56.1 (2.208)	55.1 (2.169)	44.1 (1.736)	57.0 (2.244)	44.1 (1.736)
B - Glass Length Max.	14.0 (0.551)	14.0 (0.551)	16.5 (0.649)	16.5 (0.649)	17.0 (0.668)
C - Glass Dia. Max.	2.54 (0.1)	2.54 (0.1)	2.8 (0.110)	2.7 (0.106)	2.8 (0.110)
D - Lead Dia.	0.5 (0.019)	0.5 (0.019)	0.6 (0.023)	0.6 (0.023)	0.5 (0.019)
Specifications					
	FORM C		FORM A		
Pull-In Range	10-30 AT	10-30 AT	20-40 AT	20-40 AT	10-50 AT
Rated Power Max.	3W	3W	50W	50W	10W
Switching Voltage	30VAC / DC	30VDC	100VAC / DC	100VAC / DC	100VAC / DC
Switching Current	0.2A DC	0.2A DC	0.5A DC inrush 3A	0.5A DC inrush 3A	0.4A DC
Highlights	KOFU	KOFU	KOFU	KOFU	KOFU
UL Certificate NRNT2.E70063					



	Miniature 16-21mm		
Reed Switch Series	ORD229	ORD2210	ORD2210V
Description	Pressurized		Vacuum
* Most Used	High Breakdown Voltage		High Breakdown Voltage
Dimensions in mm (inches)			
A - Overall Length	55.4 (2.181)	55.4 (2.181)	55.4 (2.181)
B - Glass Length Max.	21.0 (0.826)	21.0 (0.826)	21.0 (0.826)
C - Glass Dia. Max.	2.75 (0.108)	2.75 (0.108)	2.75 (0.108)
D - Lead Dia.	0.6 (0.023)	0.6 (0.023)	0.6 (0.023)
Specifications			
	FORM A		
Pull-In Range	20-60 AT	15-60 AT	20-60 AT
Rated Power Max.	50W	50W	100W
Switching Voltage	350VDC / 300VAC	200VDC / 150VAC	350VDC / 300VAC
Switching Current	0.7A DC / 0.5A AC	1.0A DC / 0.7A AC	1.0A DC
Highlights	KOFU	KOFU	KOFU
UL Certificate NRNT2.E70063			

ORD/ORT switches are measured with Standex Electronics Japan (KOFU) standard coils. Pull-In value is measured with tolerances of +/-2AT



CUSTOM SENSORS

“Complex problems deserve custom solutions”

Standex Electronics incorporates our magnetic reed switches into a wide variety of custom proximity sensors and switches. The reed sensors come in hundreds of different sizes and shapes to meet a multitude of different application requirements. Customers have the opportunity to work with our engineers to design or select the best packaging concept that will line up with their application.

Our unique and patented production process allows us to produce not only very small reed switches, but when we incorporate these into proximity sensors the result is a small sensor with big performance impact.

These ultra-miniature components allow big improvements in the performance of diverse products within medical devices, security systems, safes, and industrial control applications.



SENSING TECHNOLOGIES

Customer Focused
Engineering
Solutions

reed

- No power required
- Reliable 2-wire device
- High-end sensing applications
- World leader in reed technology/applications

TYPES OF SENSORS

- Proximity
- Push Button
- Fluid Flow
- Pressure Differential
- Metal Detection
- Fluid Level



combo

- Combine any of our sensing technologies and temperature together for multi-sensing/smart sensing

TYPES OF SENSORS

- Various technologies



hall effect

- Advanced outputs over reed on / off
- Ideal for speed sensing
- Power consumption in low mA

TYPES OF SENSORS

- Proximity
- Angular
- Fluid Level
- Linear
- Speed
- Fluid Flow



capacitive

- Continuous analog output for fluid level sensing
- Solid state solution with no moving parts
- Capable of working over a wide temperature range

TYPES OF SENSORS

- Fluid Level



magneto resistive (AMR, GMR & TMR)

- Highest sensitivity
- Very low power consumption
- High accuracy over wide temperature range

TYPES OF SENSORS

- Proximity
- Angular
- Fluid Level
- Linear
- Speed
- Fluid Flow

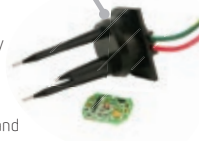

inductive

- Non contact metal detection
- Ideal in applications with small changes in position
- Solid-state reliability

TYPES OF SENSORS

- Proximity
- Metal Detection



conductive

- Solid state reliability
- Measure fluid quality (WIF, Salinity, etc.)
- Patented false full and electrolysis protection

TYPES OF SENSORS

- Fluid Level
- Fluid Quality

That's **Standex** | Strong.

standexelectronics.com

REED SENSORS

MK24 - $\frac{B}{1} - \frac{0}{2} - \frac{0E}{3}$

Surface Mount (SMD)

Rated Power Max. 3W/30VDC/0.3A | Operating Range 5-30 AT | Contact Form A, B

- Sensitivity Range AT: A=5-10, B=10-15, C=15-20, D=20-25, +5AT spans
- Lead Design: 1 (Axial), 2 (Gull-Wing), 3 (J-Lead)
- Option: Contact Form B (Normally Closed)

Highlights



- On/Off control switch, position detection
- Portable medical device, white goods, telecomm, security
- Supplied in tape and reel according to IEC 286 / part 3
- Worlds smallest SMD reed sensor

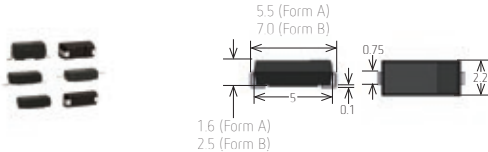

MK31 - $\frac{B}{1} - \frac{3}{2}$

Surface Mount (SMD)

Rated Power Max. 3W/30VDC/0.3A | Operating Range 5-30 AT | Contact Form A

- Sensitivity Range AT: B=10-15, C=15-20, D=20-25, ...+5AT increments
- Lead Design: 3 (J-Lead)

Highlights



- On/Off control switch, position detection
- Portable medical device, white goods, telecomm, security
- Supplied in tape and reel according to IEC 286 / part 3
- J-lead, UL

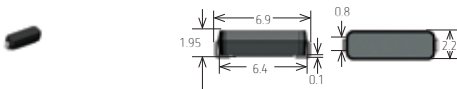

MK23 - $\frac{000}{1} - \frac{0}{2} - \frac{0}{3}$

Surface Mount (SMD)

Rated Power Max. 100W/1000VDC/1A | Operating Range 10-60 AT | Contact Form A, C

- Switch Model: 35, 46, 52, 66, 80, 85, 87, 90 (Form C), 501
- Sensitivity Range AT: B=10-15, C=15-20, D=20-25, ...+5AT increments
- Lead Design: 1 (Axial), 2 (Gull-Wing), 5 (Helix)

Highlights



- On/Off control switch, position detection
- Telecomm, white goods, industrial, security
- Supplied in tape and reel according to IEC 286 / part 3
- Axial, Gull-Wing, inverse Gull-Wing, or helix lead, UL

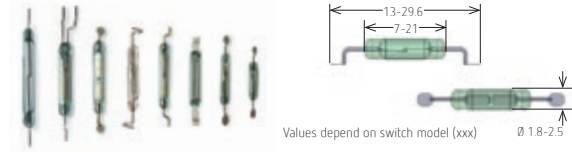

MK17 - $\frac{B}{1} - \frac{0}{2}$

Surface Mount (SMD)

Rated Power Max. 10W/170VDC/0.25A | Operating Range 10-40 AT | Contact Form A

- Sensitivity Range AT: B=10-15, C=15-20, D=20-25, ...+5AT increments
- Lead Design: 1 (Axial), 2 (Gull-Wing), 3 (J-Lead)

Highlights



- On/Off control switch, position detection
- Portable medical device, white goods, telecomm, security
- Supplied in tape and reel according to IEC 286 / part 3
- Axial, Gull-Wing or J-lead, UL

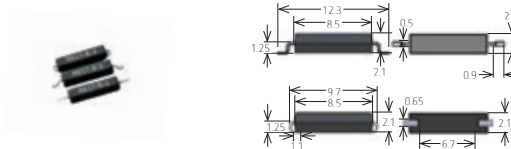

Note: All dimensions are in mm and tolerances according to ISO 2768-m. Please refer to the product datasheets on our website for full dimensions, specifications, tolerances, etc. Not all part number combinations are possible, consult the factory for more info. We reserve the right to make any changes according to technological progress or further developments. All product images are scaled 1:1 unless otherwise noted.

MK22 - $\frac{B}{1} - \frac{Q}{2}$

Surface Mount (SMD)

Rated Power Max. 20W/200VDC/1.0A | Operating Range 10-30 AT | Contact Form A

- Sensitivity Range AT: B=10-15, C=15-20, D=20-25, ...+5AT increments
- Lead Design: 1 (Axial), 2 (Short Gull-Wing), 4 (Long Gull-Wing)

Highlights



- On/Off control switch, position detection
- Portable medical device, white goods, telecomm, security
- Supplied in tape and reel according to IEC 286/part 3
- Axial or Gull-Wing lead, UL

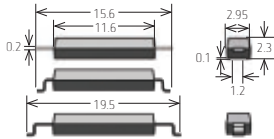

MK16 - $\frac{B}{1} - \frac{Q}{2}$

Surface Mount (SMD)

Rated Power Max. 10W/200VDC/0.5A | Operating Range 10-60 AT | Contact Form A

- Sensitivity Range AT: B=10-15, C=15-20, D=20-25, ...+5AT increments
- Lead Design: 1 (Axial), 2 (Gull-Wing)

Highlights



- On/Off control switch, position detection
- Portable medical device, white goods, telecomm, security
- Supplied in tape and reel according to IEC 286/part 3
- Axial or Gull-Wing lead, UL

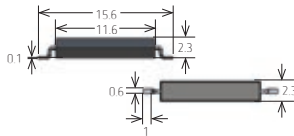

MK23 - $\frac{501}{1} - \frac{B}{2} - \frac{Q}{2}$ "Helix"

Surface Mount (SMD)

Rated Power Max. 10VA/200VDC/0.5A | Operating Range 7-30 AT | Contact Form A

- Sensitivity Range AT: B=10-15, C=15-20, D=20-25, E=25-30
- Lead Design: 5 (Helix)

Highlights



- On/Off control switch, position detection
- Telecomm, white goods, industrial, security
- Supplied in tape and reel according to IEC 286/part 3
- Axial or Helix lead, UL

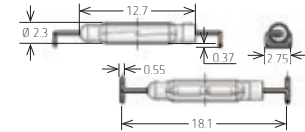

MK15 - $\frac{B}{1} - \frac{Q}{2}$

Surface Mount (SMD)

Rated Power Max. 10W/200VDC/0.5A | Operating Range 10-60 AT | Contact Form A, B

- Sensitivity Range AT: B=10-15, C=15-20, D=20-25, ...+5AT increments
- Lead Design: 1 (Axial), 2 (Gull-Wing)

Highlights



- On/Off control switch, position detection
- Telecomm, white goods, industrial, security
- Supplied in tape and reel according to IEC 286/part 3
- Axial or Gull-Wing lead, high power switch, UL

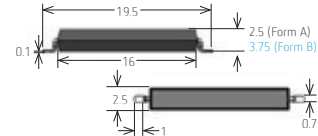



Note: All dimensions are in mm and tolerances according to ISO 2768-m. Please refer to the product datasheets on our website for full dimensions, specifications, tolerances, etc. Not all part number combinations are possible, consult the factory for more info. We reserve the right to make any changes according to technological progress or further developments. All product images are scaled 1:1 unless otherwise noted.

MK01 - $\frac{X}{1}$

Surface Mount (SMD)

Rated Power Max. 10VA/200VDC/0.5A | Operating Range 10-60 AT | Contact Form A, B, C

- | | |
|---|-------------------|
| <ol style="list-style-type: none"> Sensitivity Range AT: B=10-15, C=15-20, D=20-25, E=25-30 (Form A,B)
H=15-20, I=20-25, K=25-30 (Form C) <ul style="list-style-type: none"> On/Off control switch, position detection Telecomm, white goods, industrial, security Supplied in tape and reel according to IEC 286/part 3 J-Lead, high power switch, UL | <p>Highlights</p> |
|---|-------------------|

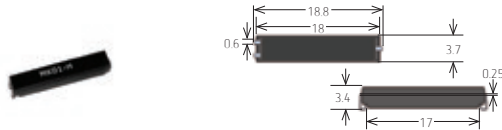

MK02 $\frac{0}{1} - \frac{1}{2} \frac{X}{3} \frac{00}{4} - \frac{0000}{5} \frac{X}{Termination}$

Metal Detection

Rated Power Max. 10W/200VDC/0.5A | Operating Range 4.5-15 MM

- | | |
|---|-------------------|
| <ol style="list-style-type: none"> Operation Series: 0, 1, 2, 3, 4 Contact Quantity: 1 Contact Form: A, B, C Switch Model: 66, 90 Cable Length (mm): 200, 300, 500, 1000, 1500, 2000, 3000, 5000 <ul style="list-style-type: none"> Integrated magnet (Only MK02/4 requires ext. magnet), Front or above operation | <p>Highlights</p> |
|---|-------------------|

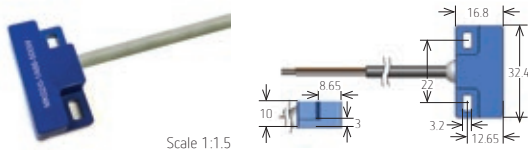

MK28 - $\frac{1}{1} \frac{X}{2} - \frac{000}{3} \frac{X}{Termination}$

Metal Detection

Rated Power Max. 10W/175VDC/0.5A | Operating Range Exact

- | | |
|---|-------------------|
| <ol style="list-style-type: none"> Contact Quantity: 1 Contact Form: A, B, C Switch Model: 90 Cable Length (mm): 500 <ul style="list-style-type: none"> Vane operated screw mount proximity/motion sensor (integrated magnet) Automotive, industrial automation equipment, robotics, harsh environments | <p>Highlights</p> |
|---|-------------------|

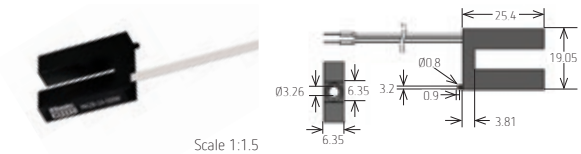

MK04 - $\frac{1}{1} \frac{X}{2} \frac{00}{3} \frac{0}{4} - \frac{0000}{5} \frac{W}{Termination}$

Screw Flange

Rated Power Max. 10W/400VDC/0.5A | Operating Range 10-60 AT

- | | |
|--|-------------------|
| <ol style="list-style-type: none"> Contact Quantity: 1 Contact Form: A, B, C Switch Model: 66, 90 Sensitivity Range AT: B=10-15, C=15-20, D=20-25, ...+5AT increments Cable Length (mm): 200, 300, 500, 1000, 1500, 2000, 3000, 5000 <p>*Magnet sold separate</p> | <p>Highlights</p> |
|--|-------------------|

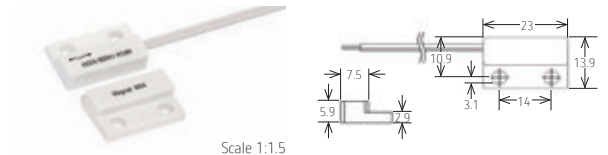

Note: All dimensions are in mm and tolerances according to ISO 2768-m. Please refer to the product datasheets on our website for full dimensions, specifications, tolerances, etc. Not all part number combinations are possible, consult the factory for more info. We reserve the right to make any changes according to technological progress or further developments. All product images are scaled 1:1 unless otherwise noted.

MK05 - $\frac{1}{1} \times \frac{00}{2} \frac{0}{3} \frac{0}{4} - \frac{0000}{5} \frac{W}{\text{Termination}}$

Screw Flange

Rated Power Max. 10W/400VDC/0.5A | Operating Range 10-60 AT

- Contact Quantity: 1
- Contact Form: A, B, C
- Switch Model: 66, 90
- Sensitivity Range AT: B=10-15, C=15-20, D=20-25, ...+5AT increments
- Cable Length (mm): 200, 300, 500, 1000, 1500, 2000, 3000, 5000

*Magnet sold separate

Highlights



Position, level, and end limit sensing

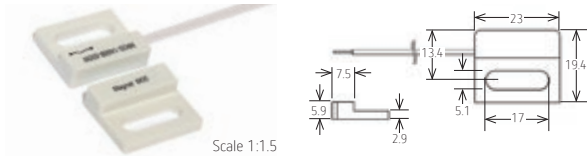

Scale 1:1.5

MK13 - $\frac{1}{1} \times \frac{00}{2} \frac{0}{3} \frac{0}{4} - \frac{0000}{5} \frac{W}{\text{Termination}}$

Screw Flange

Rated Power Max. 10W/400VDC/0.5A | Operating Range 10-60 AT

- Contact Quantity: 1
- Contact Form: A, B, C
- Switch Model: 66, 90
- Sensitivity Range AT: B=10-15, C=15-20, D=20-25, ...+5AT increments
- Cable Length (mm): 200, 300, 500, 1000, 1500, 2000, 3000, 5000

*Magnet sold separate

Highlights



Position, level, and end limit sensing

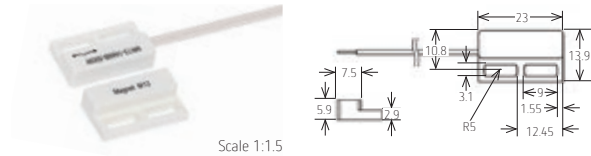

Scale 1:1.5

MK12 - $\frac{1}{1} \times \frac{00}{2} \frac{0}{3} \frac{0}{4} - \frac{0000}{5} \frac{W}{\text{Termination}}$

Screw Flange

Rated Power Max. 10W/400VDC/0.5A | Operating Range 10-60 AT

- Contact Quantity: 1
- Contact Form: A, B, C
- Switch Model: 66, 90
- Sensitivity Range AT: B=10-15, C=15-20, D=20-25, ...+5AT increments
- Cable Length (mm): 200, 300, 500, 1000, 1500, 2000, 3000, 5000

*Magnet sold separate

Highlights



Position, level, and end limit sensing

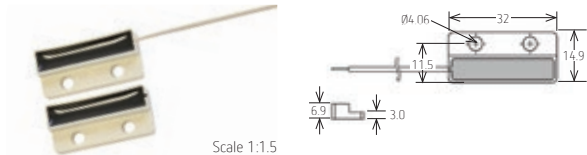

Scale 1:1.5

MK26 - $\frac{1}{1} \times \frac{00}{2} \frac{0}{3} \frac{0}{4} - \frac{0000}{5} \frac{W}{\text{Termination}}$

Screw Flange

Rated Power Max. 100W/1000VDC/1.0A | Operating Range 10-60 AT

- Contact Quantity: 1
- Contact Form: A, B, C
- Switch Model: 66, 90
- Sensitivity Range AT: B=10-15, C=15-20, D=20-25, ...+5AT increments
- Cable Length (mm): 200, 300, 500, 1000, 1500, 2000, 3000, 5000
- Termination: W

*Magnet sold separate

Highlights



Position, level, and end limit sensing

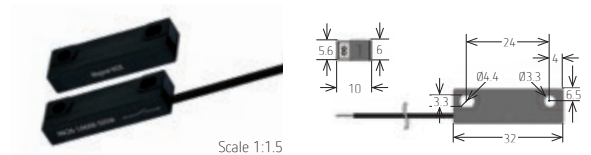

Scale 1:1.5



Note: All dimensions are in mm and tolerances according to ISO 2768-m. Please refer to the product datasheets on our website for full dimensions, specifications, tolerances, etc. Not all part number combinations are possible, consult the factory for more info. We reserve the right to make any changes according to technological progress or further developments. All product images are scaled 1:1 unless otherwise noted.

MK27 - 1 A 00 0 - 000 W
 1 2 3 4 5 Termination

Screw Flange

Rated Power Max. 100W/1000VDC/1.0A | Operating Range 10-60 AT

- 1 Contact Quantity: 1
 - 2 Contact Form: A
 - 3 Switch Model: 66, 85
 - 4 Sensitivity Range AT: B=10-15, C=15-20, D=20-25, ...+5AT increments
 - 5 Cable Length (mm): 500
- *Magnet included

Highlights



Position, level, and end limit sensing up to 40mm



Scale 1:2

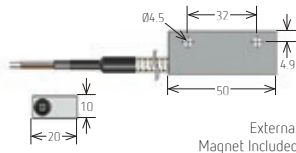

External Magnet Included

MK21 / X - 1 X 00 0 - 0000 W
 1 2 3 4 5 6 Termination

Screw Flange

Rated Power Max. 100W/1000VDC/1.0A | Operating Range 10-60 AT

- 1 Case Version: P=Potted, M=Molded (M = High Temp +150°C)
 - 2 Contact Quantity: 1
 - 3 Contact Form: A, B, C
 - 4 Switch Model: 66, 90
 - 5 Sensitivity Range AT: B=10-15, C=15-20, D=20-25, ...+5AT increments
 - 6 Cable Length (mm): 500, 1000, 1500, 2000, 3000, 5000
- *Magnet sold separate

Highlights



Position, level, and end limit sensing



Scale 1:1.5

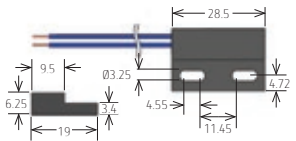

MK20 / 2 - X - 000 W
 1 2 Termination

Cylindrical

Rated Power Max. 3W/30VDC/0.25A | Operating Range 10-30 AT

- 1 Contact Quantity: 1
 - 2 Contact Form: A
 - 3 Switch Model: 04
 - 1 Sensitivity Range AT: B=10-15, D=20-25
 - 2 Cable Length (mm): 100, 200, 300, 500
- *Magnet sold separate

Highlights



Position, level, and end limit sensing

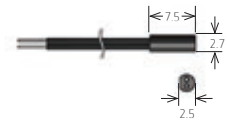

MK20 / 1 - X - 000 W
 1 2 Termination

Cylindrical

Rated Power Max. 10W/30VDC/0.25A | Operating Range 10-60 AT

- 1 Contact Quantity: 1
 - 2 Contact Form: A
 - 3 Switch Model: 80
 - 1 Sensitivity Range AT: B=10-15, C=15-20, D=20-25, E=25-30
 - 2 Cable Length (mm): 100, 200, 300, 500
- *Magnet sold separate

Highlights



Position, level, and end limit sensing

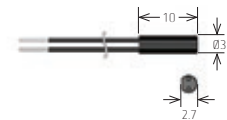

Note: All dimensions are in mm and tolerances according to ISO 2768-m. Please refer to the product datasheets on our website for full dimensions, specifications, tolerances, etc. Not all part number combinations are possible, consult the factory for more info. We reserve the right to make any changes according to technological progress or further developments. All product images are scaled 1:1 unless otherwise noted.

MK18 - X - 0000 W

1 2 Termination

Cylindrical

Rated Power Max. 10W/200VDC/0.5A | Operating Range 10-60 AT

- 1 Contact Quantity: 1
- 2 Contact Form: A
- Switch Model: 87
- 1 Sensitivity Range AT: B=10-15, C=15-20, D=20-25, E=25-30
- 2 Cable Length (mm): 100, 200, 300, 500, 1000, 1500

*Magnet sold separate

Highlights



5.0mm
Position, level,
and end limit
sensing



MK14 - 1 X 00 0 - 0000 W

1 2 3 4 5 Termination

Cylindrical

Rated Power Max. 10W/400VDC/0.5A | Operating Range 10-60 AT

- 1 Contact Quantity: 1
- 2 Contact Form: A, B, C
- 3 Switch Model: 66, 90
- 4 Sensitivity Range AT: B=10-15, C=15-20, D=20-25, ...+5AT increments
- 5 Cable Length (mm): 200, 300, 500, 1000, 1500

*Magnet sold separate

Highlights



4.0mm
Position, level,
and end limit
sensing



MK03 - 1 X 00 0 - 0000 W

1 2 3 4 5 Termination

Cylindrical

Rated Power Max. 10W/400VDC/0.5A | Operating Range 10-60 AT

- 1 Contact Quantity: 1
- 2 Contact Form: A, B, C
- 3 Switch Model: 66, 90
- 4 Sensitivity Range AT: B=10-15, C=15-20, D=20-25, ...+5AT increments
- 5 Cable Length (mm): 200, 300, 500, 1000, 1500, 2000, 3000, 5000

*Magnet sold separate

Highlights



5.75mm
Position, level,
and end limit
sensing



MK08 - 1 X 00 - 0000 W

1 2 3 4 Termination

Cylindrical

Rated Power Max. 60W/400VDC/1.0A | Operating Range 10-60 AT

- 1 Contact Quantity: 1
 - 2 Contact Form: A, B
 - 3 Switch Model: 66, 85
 - 4 Cable Length (mm): 200, 300, 500, 1000, 1500
- (KEMA 00ATEX1112 X, IECEx KEM09.0006 X according to DIN EN 60062)

Highlights



Oil resistant wire
Operate
-40°C to +130°C

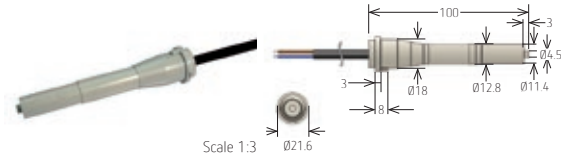

Note: All dimensions are in mm and tolerances according to ISO 2768-m. Please refer to the product datasheets on our website for full dimensions, specifications, tolerances, etc. Not all part number combinations are possible, consult the factory for more info. We reserve the right to make any changes according to technological progress or further developments. All product images are scaled 1:1 unless otherwise noted.

MK11 - 1 X 00 0 - 0000 W
 2 3 4 5 6 Termination

Threaded Barrel

Rated Power Max. 10W/200VDC/0.5A | Operating Range 10-60 AT

- Case, Thread Size: Stainless Steel M5 or M8
 - 1 Contact Quantity: 1
 - 2 Contact Form: A, B, C
 - 3 Switch Model: 66, 85, 90
 - 4 Sensitivity Range AT: C=15-20, D=20-25, E=25-30, ...+5AT increments
 - 5 Cable Length (mm): 200, 300, 500, 1000, 1500, 2000, 3000, 5000
- *Magnet sold separate

Highlights



Position, level, and end limit detection and sensing adjustment

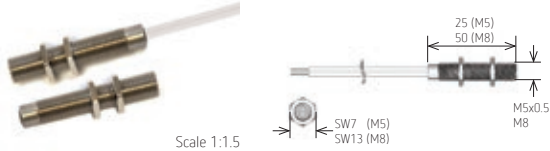

MK11 / B00 - 1 X 00 0 - 0000 W
 1 2 3 4 5 6 Termination

Threaded Barrel

Rated Power Max. 100W/1000VDC/1.0A | Operating Range 10-60 AT

- Case, Thread Size: B=Brass, 6=M6, 8=M8, 10=M10, 12=M12
 - 2 Contact Quantity: 1
 - 3 Contact Form: A, B, C
 - 4 Switch Model: 66, 85, 90
 - 5 Sensitivity Range AT: C=15-20, D=20-25, E=25-30, ...+5AT increments
 - 6 Cable Length (mm): 200, 300, 500, 1000, 1500, 2000, 3000, 5000
- *Magnet sold separate

Highlights



Position, level, and end limit detection and sensing adjustment

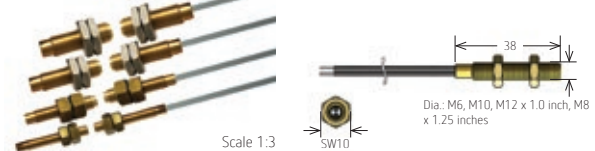

MK11 / M8 - 1 X 00 0 - 0000 W
 1 2 3 4 5 Termination

Threaded Barrel

Rated Power Max. 100W/1000VDC/1.0A | Operating Range 10-60 AT

- Case, Thread Size: Plastic M8
 - 1 Contact Quantity: 1
 - 2 Contact Form: A, B, C
 - 3 Switch Model: 66, 85, 90
 - 4 Sensitivity Range AT: C=15-20, D=20-25, E=25-30, ...+5AT increments
 - 5 Cable Length (mm): 200, 300, 500, 1000, 1500, 2000, 3000, 5000
- *Magnet sold separate

Highlights



Position, level, and end limit detection and sensing adjustment

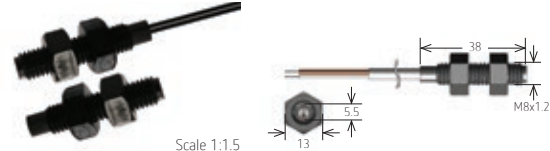

MK07 - 1 X 00 0 - 0000 W
 2 3 4 5 6 Termination

Threaded Barrel

Rated Power Max. 10W/200VDC/0.5A | Operating Range 10-60 AT

- Case, Thread Size: Plastic M8
 - 1 Contact Quantity: 1
 - 2 Contact Form: A, B
 - 3 Switch Model: 66, 85, 90
 - 4 Sensitivity Range AT: C=15-20, D=20-25, E=25-30, ...+5AT increments
 - 5 Cable Length (mm): 200, 300, 500, 1000, 1500
- *Magnet sold separate

Highlights



Position, level, and end limit sensing



SOLUTIONS | Reed Sensors

Note: All dimensions are in mm and tolerances according to ISO 2768-m. Please refer to the product datasheets on our website for full dimensions, specifications, tolerances, etc. Not all part number combinations are possible, consult the factory for more info. We reserve the right to make any changes according to technological progress or further developments. All product images are scaled 1:1 unless otherwise noted.



MK10 - $\frac{C}{1} - \frac{270}{2}$

Other Packaging

Rated Power Max. 10W/170VDC/0.25A | Operating Range 10-40 AT | Contact Form A

- | | |
|--|------------|
| 1 Sensitivity Range AT: B=10-15, C=15-20, D=20-25, E=25-30 | Highlights |
| 2 Resistance Q: 270 (others available) | |

- On/Off control switch, position detection
- Level sensing applications
- Excellent for low power operation

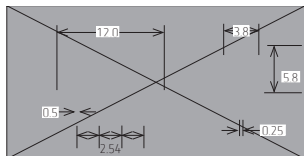

MK06 - $\frac{00}{1} - \frac{X}{2}$

Other Packaging

Rated Power Max. 10W/170-200VDC/0.25-0.5A | Operating Range 10-60 AT

- | | |
|--|------------|
| 1 Package Length (mm): 4=12.06, 5=14.30, 6=17.24, 7=19.78, 8=22.32, 10=28.50 | Highlights |
|--|------------|

- | | |
|---|--|
| 2 Sensitivity Range AT: B=10-15, C=15-20, D=20-25, E=25-30 (Form A,B)
H=15-20, I=20-25, K=25-30 (Form C) | |
| Switch Model: 66, 87, 90 (Form E Latching option) | |



Scale 1:1.5

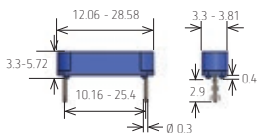

On/Off control switch, position detection
1inch (2.54mm) pin spacing

MK09 - $\frac{1}{1} \frac{A}{2} \frac{00}{3} - \frac{0}{4}$

Other Packaging

Rated Power Max. 10W/180VDC/1.25A | Operating Range 10-30 AT

- | | |
|--|------------|
| 1 Contact Quantity: 1 | Highlights |
| 2 Contact Form: A, B, C | |
| 3 Switch Model: 66, 84, 90 | |
| 4 Sensitivity Range AT: B=10-15, C=15-20, D=20-25, E=25-30 | |

*Reed sensor integrated into a standard Hirschmann connector

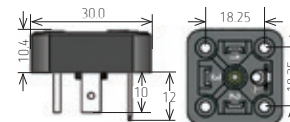

MK25 - $\frac{1}{1} \frac{X}{2} \frac{00}{3} - \frac{0000}{4} \frac{W}{Termination}$

Other Packaging

Rated Power Max. 10W/400VDC/0.5A | Push Button Reed Sensor / Contactless Switching

- | | | |
|--|------------------------|------------|
| 1 Contact Quantity: 1 | Operate -40°C to +60°C | Highlights |
| 2 Contact Form: A, B, C | (KEMA 05ATEX1206 X) | |
| 3 Switch Model: 46, 90 according to EN 60062 | | |
| 4 Cable Length (mm): 200, 300, 500, 1000, 1500, 2000, 3000, 5000 | | |

*Button Accessories Sold Separate



Scale 1:1.5

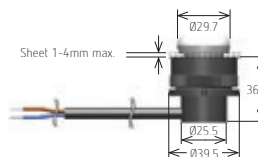

Button plates, emergency stop buttons, etc. can be provided with laser inscriptions as required. The information is burnt into the surface and thus, unlike with print-inscribed elements, is very durable.

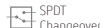
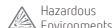

				
	LOW			HIGH
costs	Ferrite	AlNiCo	NdFeB	SmCo
energy (WxH max.)	Ferrite	AlNiCo	SmCo	NdFeB
working temperature	NdFeB	Ferrite	SmCo	AlNiCo
corrosion - resistant	NdFeB	SmCo	AlNiCo	Ferrite
opposing field - resistant	AlNiCo	Ferrite	NdFeB	SmCo
mechanical strength	Ferrite	SmCo	NdFeB	AlNiCo
temperature coefficient	AlNiCo	SmCo	NdFeB	Ferrite

A Reed Switch requires either a permanent magnet or magnetic field in order to activate the switch, thus it is commonly called a magnetic reed switch. Magnets have reversible and irreversible demagnetization specifications. Engineers should consider shock, vibration, strong external magnetic fields as well as high

temperatures in their designs. All these factors influence the magnetic force and the long term stability in different ways.

Preferably the magnet is mounted on the moving part of the application. Professional tuning of the magnet and reed switch pairing can improve the functionality of the whole sensor-magnet system. We offer permanent magnets in various standard housings for quick mounting or as is.

We offer the following types of permanent magnets:

- AlNiCo (Aluminum Nickel, Cobalt, Iron and Titanium)
- SmCo (Samarium–Cobalt) & NdFeB (Neodymium) - rare earth
- Hf - hard ferrite

These are some of our most widely used models, others available as required.

Dimensions in mm

AlNiCo

AlNiCo Ø2.5 x 12.7
 AlNiCo Ø3.0 x 12.0
 AlNiCo Ø4.0 x 19.0
 AlNiCo Ø5.0 x 4.0
 AlNiCo Ø5.0 x 20.0
 AlNiCo Ø5.5 x 22.0
 AlNiCo Ø7.5 x 27.0
 AlNiCo 3.2 x 3.2 x 19.0



Rare Earth

SmCo5 Ø1.9 x 3
 SmCo5 Ø3 x 4
 NdFeB N35 Ø4 x 19
 NdFeB N35H Ø4 x 19
 NdFeB N45 Ø4 x 19
 NdFeB 250/175H Ø6 x 10
 NdFeB 250/175H 10 x 5 x 1.9



Hard Ferrite

Hf 28/26 2.6 x 2.6 x 4.0
 Hf 28/26 3.5 x 1.8 x 1.8
 Hf 28/26 6.7 x 6.7 x 2.7



SOLUTIONS | Magnets

Note: All dimensions are in mm and tolerances according to ISO 2768-m. Please refer to the product datasheets on our website for full dimensions, specifications, tolerances, etc. Not all part number combinations are possible, consult the factory for more info. We reserve the right to make any changes according to technological progress or further developments. All product images are scaled 1:1 unless otherwise noted.

M02

M04

M13

M05

M21 / P(1,2)

Magnets in Housings

Dimensions in mm (inches)

L - 32.4 (1.275)	L - 23 (0.905)	L - 23 (0.905)	L - 23.2 (0.913)	L - 28.6 (1.125)
W - 16.7 (0.657)	W - 13.9 (0.547)	W - 13.9 (0.547)	W - 19.6 (0.771)	W - 19 (0.748)
H - 10 (0.393)	H - 5.9 (0.232)	H - 5.9 (0.232)	H - 5.9 (0.232)	H - 6.35 (0.25)



M27

M11(B)

M11(S)

M11(P)

M03

Magnets in Housings

Dimensions in mm (inches)

L - 50.0 (1.969)	L - 38 (1.496)	L - 25 (0.984)	L - 38 (1.496)	L - 25 (0.984)
W - 20.0 (0.787)	Ø - M6-M12	Ø - M5 x 0.5 / M8 x 0.5	Ø - M8 x 1.25	Ø - M5 x 0.5
H - 10.0 (0.394)	-	-	-	-

Scale 1:1.5

Scale 1:2.25



SENSOR ACTIVATION DISTANCES

Reed Sensor	Magnetic Sensitivity mT	Position and Movement Max. Pull-in Distance in mm					Position and Movement Min. Drop-out Distance in mm				
		D1	D2	D3	D4	D5	D1	D2	D3	D4	D5
MK03-1A66B-500W	> 1.70	15.0	6.5	9.3	8.5	8.5	17.5	8.0	11.4	10.1	10.1
MK03-1A66C-500W	> 2.30	13.0	4.4	7.4	7.2	7.2	16.5	6.5	9.9	9.5	9.5
MK03-1A66D-500W	> 2.70	11.0	4.0	5.7	6.5	6.5	14.5	5.5	8.5	9.0	9.0
MK03-1A66E-500W	> 3.10	10.0	3.5	4.5	5.7	5.7	13.5	5.0	8.0	8.5	8.5
MK04-1A66B-500W	> 1.70	15.0	6.5	9.3	8.5	8.5	17.5	8.0	11.4	10.1	10.1
MK04-1A66C-500W	> 2.30	13.0	4.4	7.4	7.2	7.2	16.5	6.5	9.9	9.5	9.5
MK04-1A66D-500W	> 2.70	11.0	4.0	5.7	6.5	6.5	14.5	5.5	8.5	9.0	9.0
MK04-1A66E-500W	> 3.10	10.0	3.5	4.5	5.7	5.7	13.5	5.0	8.0	8.5	8.5
MK05-1A66B-500W	> 1.70	15.0	6.5	9.3	8.5	8.5	17.5	8.0	11.4	10.1	10.1
MK05-1A66C-500W	> 2.30	13.0	4.4	7.4	7.2	7.2	16.5	6.5	9.9	9.5	9.5
MK05-1A66D-500W	> 2.70	11.0	4.0	5.7	6.5	6.5	14.5	5.5	8.5	9.0	9.0
MK05-1A66E-500W	> 3.10	10.0	3.5	4.5	5.7	5.7	13.5	5.0	8.0	8.5	8.5
MK11/M8-1A66B-500W	> 1.70	15.0	6.5	9.3	8.5	8.5	17.5	8.0	11.4	10.1	10.1
MK11/M8-1A66C-500W	> 2.30	13.0	4.4	7.4	7.2	7.2	16.5	6.5	9.9	9.5	9.5
MK11/M8-1A66D-500W	> 2.70	11.0	4.0	5.7	6.5	6.5	14.5	5.5	8.5	9.0	9.0
MK11/M8-1A66E-500W	> 3.10	10.0	3.5	4.5	5.7	5.7	13.5	5.0	8.0	8.5	8.5
MK13-1A66B-500W	> 1.70	15.0	6.5	9.3	8.5	8.5	17.5	8.0	11.4	10.1	10.1
MK13-1A66C-500W	> 2.30	13.0	4.4	7.4	7.2	7.2	16.5	6.5	9.9	9.5	9.5
MK13-1A66D-500W	> 2.70	11.0	4.0	5.7	6.5	6.5	14.5	5.5	8.5	9.0	9.0
MK13-1A66E-500W	> 3.10	10.0	3.5	4.5	5.7	5.7	13.5	5.0	8.0	8.5	8.5

Resulting from position and movement of the actuator magnet.

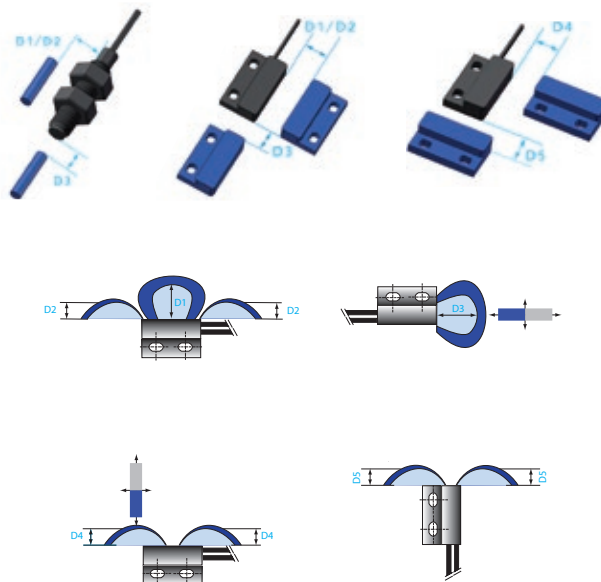

All distance data above are valid for the magnets below:

4003004003 / Perm. magnet Ø4 x 19mm
 2500000002 / M02
 2500000004 / M04

2500000005 / M05
 2500000013 / M13
 2500000021 / M21

HALL EFFECT SENSORS

Standex Electronics' Hall Effect Sensor series offer **solid state reliability**, **low power consumption**, and consistent activation points over a wide temperature range in a rugged and environmentally isolated package.

Micro-Power versions operate on 2.5-3.5V battery voltage with only 5µA average supply current vs. the industry average of 5mA.

Custom options include: output- switch, latch, etc., high temperature resistance, package design and much more.

MH21 - 00 X - 000 W

1 2 3 Termination

Screw Flange

Standard Power 3-24VDC/4mA ($V_{CC}=12V$) | Micro Power 2.5-3.5V/10µA ($V_{CC}=3.5V$)

- 1 Power Version: 11 = Standard Power, 10 = Micro Power
- 2 Function: Switch, *Latch (*Standard Power only)
- 3 Cable Length (mm): 300, 500, other lengths as needed

Highlights

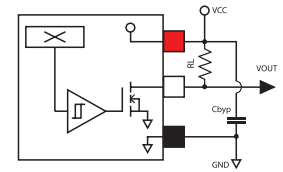
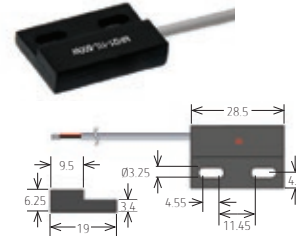

MH04 - 00 X - 000 W

1 2 3 Termination

Screw Flange

Standard Power 3-24VDC/4mA ($V_{CC}=12V$) | Micro Power 2.5-3.5V/10µA ($V_{CC}=3.5V$)

- 1 Power Version: 11 = Standard Power, 10 = Micro Power
- 2 Function: Switch, *Latch (*Standard Power only)
- 3 Cable Length (mm): 300, 500, other lengths as needed

Highlights

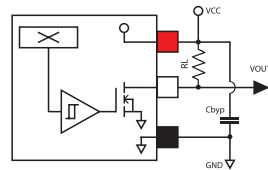
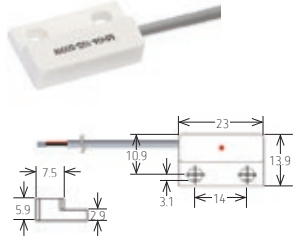

MH32 - 00 X - 000 W

1 2 3 Termination

Screw Flange

Standard Power 2.7-24VDC/25mA ($V_{CC}=12V$) | Micro Power 2.5-3.5V/10µA ($V_{CC}=3.5V$)

- 1 Power Version: 11 = Standard Power, 10 = Micro Power
- 2 Function: Bipolar Switch, *Bipolar Latch (*Standard Power only)
- 3 Cable Length (mm): 300, 500, other lengths as needed

Highlights

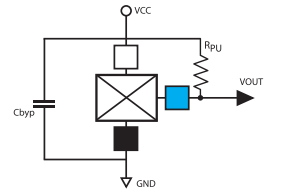
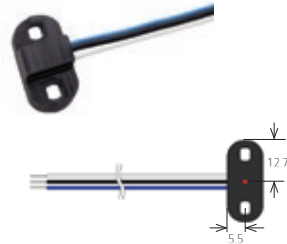

FLUID SENSORS & FLOATS

Standex Electronics supplies fluid level sensors that use a wide range of technologies - from magnetic Reed Switch technology to conductive technology. Standex Electronics designs fluid level sensors that are appropriate for each individual application. From basic sensors which are driven by external electronics to turnkey sensor systems with switched outputs, Standex Electronics delivers solutions to the most demanding fluid level sensing applications.

LS01 - 1 X 00 - PX - 0000 W

1 2 3 4 5 Termination

Single Level

Rated Power Max. 100/400VDC/1.0A | Vertical Mount

1 Contact Quantity:	1	3	Switch Model:	66, 85, 90
2 Contact Form:	A, B, C	4	Material:	PA, PP
5 Cable Length (mm):	500, 1000, 5000			

Highlights



Level control, detection and monitoring



Scale 1:2

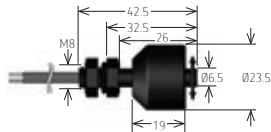

LS02 - 1 X 00 - PX - 0000 W

1 2 3 4 5 Termination

Single Level

Rated Power Max. 100/400VDC/1.0A | Vertical Mount

1 Contact Quantity:	1	3	Switch Model:	66, 85, 90
2 Contact Form:	A, B, C	4	Material:	PA, PP
5 Cable Length (mm):	500, 1000, 5000			

Highlights



Level control, detection and monitoring



Scale 1:2

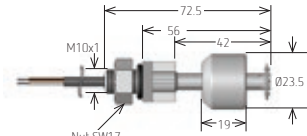

LS01 - 1 X 00 - PX - 0000 W

1 2 3 4 5 Termination

Single Level

Rated Power Max. 100/400VDC/1.0A | Vertical Mount

1 Contact Quantity:	1	3	Switch Model:	66, 85, 90
2 Contact Form:	A, B, C	4	Material:	S=Stainless
5 Cable Length (mm):	500, 1000, 5000			

Highlights



Level control, detection and monitoring



Scale 1:2

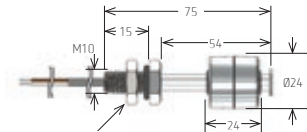

Note: All dimensions are in mm and tolerances according to ISO 2768-m. Please refer to the product datasheets on our website for full dimensions, specifications, tolerances, etc. Not all part number combinations are possible, consult the factory for more info. We reserve the right to make any changes according to technological progress or further developments. All product images are scaled 1:1 unless otherwise noted.

LS03 - 1 X 00 - PX - 0000 W
1 2 3 4 5 Termination

Single Level

Rated Power Max. 100/400VDC/1.0A | Horizontal Mount

1 Contact Quantity:	1	3	Switch Model:	66, 85, 90
2 Contact Form:	A, B, C	4	Material:	PA, PP
5 Cable Length (mm):	500, 1000, 5000			

- IP68-only up to screw in thread
- Compact Single Level Horizontal Mount Level Sensor
- High power switch option, other cables and connectors
- Shaft/Float: PA, PP

Highlights



Level control, detection and monitoring

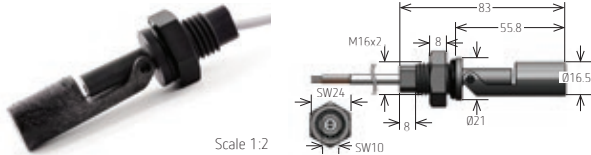

Scale 1:2

Standard Version



GZ Version



DK Version



Tank Wall

DL Version

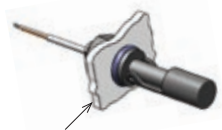

Tank Wall

KSS - BV00000

Single Level

Rated Power Max. 100/400VDC/1.0A | Horizontal Mount

1 Contact Quantity:	1
2 Contact Form:	A, B
3 Shaft/Float:	PP

Highlights



Level control, detection and monitoring

- Compact Single Level Horizontal Mount Level Sensor
- Mounted from the outside
- Ideal in blow or injection molded bottles
- Mates with Yazaki 7283-6434-40 and Packard 12162193 connector

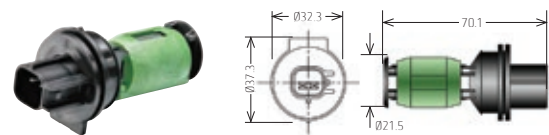

Scale 1:2

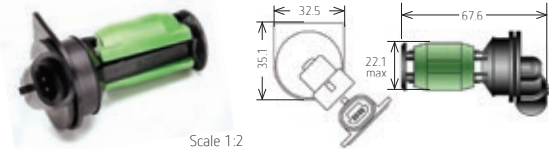

Scale 1:2

Note: All dimensions are in mm and tolerances according to ISO 2768-m. Please refer to the product datasheets on our website for full dimensions, specifications, tolerances, etc. Not all part number combinations are possible, consult the factory for more info. We reserve the right to make any changes according to technological progress or further developments. All product images are scaled 1:1 unless otherwise noted.

LS04 - 1 X 00 - 0 - 0000 W
 1 2 3 4 5 Termination

Single / Multi / Continuous

Rated Power Max. 100/400VDC/1.0A | Horizontal Mount

- | | | | |
|----------------------|-----------------|----------------------------|------------|
| 1 Contact Quantity: | 1 | 3 Switch Model: | 66, 85, 90 |
| 2 Contact Form: | A, B, C | 4 Shaft Length (mm): | 0, 2, 4, 5 |
| 5 Cable Length (mm): | 500, 1000, 5000 | 0=255, 2=130, 4=178, 5=190 | |

- Up to 6 floats, 1W-100W rated power, other cables, connectors
- Reservoir, tank, bottle or other container mounting configurations

Highlights



Single, multi and continuous level control, detection and monitoring

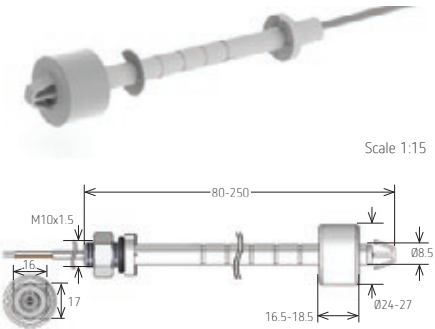

Scale 1:15

LS05 - 1 X 00 - 0 - 0000 W
 1 2 3 4 5 Termination

Single / Multi / Continuous

Rated Power Max. 100/400VDC/1.0A | Vertical Mount

- | | | | |
|----------------------|-----------------|---------------------------|------------|
| 1 Contact Quantity: | 1 | 3 Switch Model: | 66, 85, 90 |
| 2 Contact Form: | A, B, C | 4 Shaft Length (mm): | 1, 2, 5, 7 |
| 5 Cable Length (mm): | 500, 1000, 5000 | 1=55, 2=114, 5=152, 7=220 | |

- Multiple floats with a minimum 1.5" spacing
- 1W-100W rated power, other cables, connectors
- Shaft: SS, Floats: PA, PP, NBR, or SS
- High temp up to 200°C (SS) and pressure up to 12 bar

Highlights



Single, multi and continuous level control, detection and monitoring

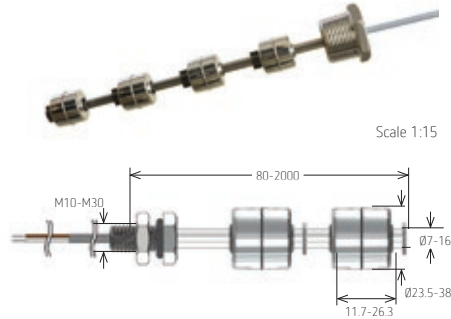

Scale 1:15

Note: All dimensions are in mm and tolerances according to ISO 2768-m. Please refer to the product datasheets on our website for full dimensions, specifications, tolerances, etc. Not all part number combinations are possible, consult the factory for more info. We reserve the right to make any changes according to technological progress or further developments. All product images are scaled 1:1 unless otherwise noted.

Series	Material	Outside Dia. mm (inches)	Inside Dia. mm (inches)	Height mm (inches)	Use with sensor	Additional Information	Floats
MS01-NBR	NBR	24.5 (0.964)	8 (0.314)	19.0 (0.748)	LS01, LS02, LS02-S LS04, LS05	Excellent resistance to petroleum derived liquids	
MS02-NBR	NBR	25.0 (0.984)	9.15 (0.360)	16.5 (0.649)			
MS18-NBR	NBR	28.5 (1.122)	9 (0.354)	16.5 (0.649)			
MS01-PA	PA	23.5 (0.925)	8.5 (0.334)	19.0 (0.748)	LS01, LS02-S LS05	High strength to weight ratio, shock and abrasion resistant	
MS02-PA	PA	25.0 (0.984)	9.15 (0.360)	16.55 (0.651)			
MS07-PA	PA	36.0 (1.417)	16.15 (0.635)	19.0 (0.748)			
MS01-PP	PP	23.5 (0.925)	8.4 (0.330)	19.0 (0.748)	LS01, LS02 LS02-S LS04, LS05	Highly resistant to chemical solvents, bases and acids	
MS02-PP	PP	25.2 (0.992)	9.15 (0.360)	16.55 (0.651)			
MS02/R-PP	PP	25.0 (0.984)	9.15 (0.360)	16.55 (0.651)			
MS03-PP	PP	27.0 (1.062)	11 (0.433)	11.7 (0.460)	All Reed Sensors	Highly resistant to chemical solvents, bases and acids	
MS04-PP	PP	18.5 (0.728)	10.2 (0.401)	20.0 (0.787)			
MS08-PP	PP	20.0 (0.787)	9.15 (0.360)	16.0 (0.630)			
MS06-PP	PP	30.0 (1.181)	N/A	8.0 (0.314)			
B12469	PP	32.6 (1.283)	N/A	22.9 (0.901)			
B12482	PP	42.0 (1.653)	11.4 (0.448)	25.0 (0.984)	R12481	Float located in bottle assembly, specific gravity per application	
B12450	PP	L - 17.5 (0.688)	W - 13.4 (0.527)	24.9 (0.980)	R11744/R12180	Float located in bottle assembly, operates with fluid specific gravity at 0.79 min	
MS09-S	V2A	24.0 (0.944)	9.5 (0.374)	24.0 (0.944)	LS02-S	Resistant to high temperatures and ideal for food and beverage industry	
MS10-S	V2A	38.3 (1.507)	9.5 (0.374)	26.3 (1.035)	LS05		

PA (Polyamide) | PP (Polypropylene) | NBR (Nitrile Butadiene Rubber) | V2A (Stainless Steel)



CUSTOM FLUID LEVEL & FLOW SENSORS

“Complex problems deserve custom solutions”

The fluid level reed sensors sense level changes in liquid in an assortment of liquid mediums. The sensors generally have an attached float with an embedded magnet that moves up and down on an encased stem where the reed switches are housed. The reed switches will change their closure state when the float comes within their magnetic influence. The closure initiates a sequence of events alerting the change of the liquid level.

We offer an extensive selection of different reed sensor packages, switch configurations, stem lengths, float density sensitivities allowing for diverse applications. Our engineers are ready to match custom designs to stringent requirements.

Our reed sensors are used in the automotive industry to measure fuel, oil, brake fluid, radiator, windshield washer level, and other fluids. They are also found in recreational vehicles, such as jet skis, sensing oil and fuel levels. Wherever a liquid exists or can accumulate, Standex Electronics offers a sensing solution.





That's **Standex** | Smart.

standexelectronics.com

HVAC/R Series Flood Prevention Switches - Reed Technology

Truly Reliable, Plug-N-Play and Hassle Free

Standex Electronics provides the HVAC industry with high performing Flood Prevention Switches (FPS's) that are easy to install and service. Our expertise and capabilities allow for reliable innovations that prevent overflowing that causes damage to floors, walls, ceilings and the like. For example, if water levels in the auxiliary or main drain pipe

rose due to a clogged air conditioning condensate, the switch shuts off the system.

Pressure Differential Sensors - Reed Technology

Differential pressure sensors are utilized in the hydraulics industry to alert equipment operators that their hydraulic fluid filter has reached the end of its life. Standex Electronics designs and

manufactures many configurations of these "filter bypass" sensors with options for custom connection methods, varying trip and reset pressures, NO/NC/SPDT switch configurations, mounting and sealing to the filter head. The hermetically sealed reed switch contacts are more reliable in these applications than other technologies such as open mechanical contacts, visual pop-up indicators, or



snap action switch assemblies. The contact quality, switching life and non-intrusive sensing arrangement of reed switches increases indicator reliability. We partner with the customer to design and validate the custom indicators to specific OEM requirements, often creating a proprietary product line for each customer.

Fluid Level Sensors - Conductive Technology

Standex Electronics manufactures state-of-the-art conductive liquid sensors that detect changes in levels without the use of a float. These sensors are used generally in water based conductive fluids when the application cannot use a float based system. Our conductive fluid level sensors have a patented false full protection and current level shift

to indicate fluid level. They guard against electrolysis and conduction paths along the sensor packaging with high quality performance. Applications include the measurement of syrups and juices in the food industry, measurement of liquid soaps in washing applications, liquid waste products, storm drains, bilge pumps, sump water, and many other functions.

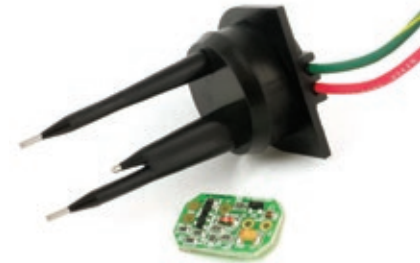



Flow Sensors - Reed Technology

Standex Electronics designs and manufactures custom reed switch and magnet based flow switches for specific customer applications. The designs often include harsh environments, significant durability requirements, and precise flow rate switching. Designs can be intrusive or non-intrusive with multiple custom packaging options for terminating and wiring and add-ons for temperature sensing, salinity, and multiple trip points.

Utilizing our vast experience in reed switch application engineering, mechanical packaging, and related manufacturing process, Standex Electronics provides quality flow switching products for markets such as home appliances and pool/spa.

Advanced Fluid Level Sensors - Hall Effect & Capacitive Technology

Standex Electronics Solid State Hall Effect Level Sensors (HLS) and Capacitive Level Sensors (CLS) are

custom designed solutions for continuous fluid level monitoring. These smart sensors have an integrated onboard microcontroller with calibrated and programmable output for various tank geometries. Our patent pending & revolutionary designs can be configured in either engineering plastic or stainless-steel housings with PP, PA, NBR, and stainless floats as well as multiple mounting options.

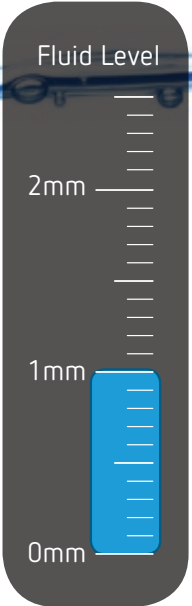

FEATURES

- Full scale accuracy up to +/- 2%
- High resolution better than 1mm (HLS)
- Solid-state reliability in harsh environments
- Custom length continuous liquid level sensing
- For fuel, oil, water, ethanol blends, diesel, urea, etc.
- Onboard electronics analog output 0-5V or 4-20mA
- Wide operating temperature -40°C to +125°C
- Can meet IP67 requirements



Standex-Meder Electronics

Robert-Bosch-Str. 4
78224 Singen/Germany

Tel. +49 7731 8399 0 salesemea@standelectronic.com
Fax +49 7731 8399 30 standelectronic.com



ttiurope.com

TTI European Headquarters

TTI, Inc.
Ganghoferstr. 34
D-82216 Maisach-Gernlinden

Tel. +49 8142 6680 -0 sales@de.ttiinc.com
Fax +49 8142 6680 -490 ttiurope.com