

SCC Series Supercapacitors

High Capacitance Cylindrical Supercapacitors



The new series of cylindrical electrochemical double-layer capacitors offers excellent pulse power handling characteristics based on the combination of very high capacitance and very low ESR. Used by themselves or in conjunction with primary or secondary batteries, they provide extended back up time, longer battery life, and provide instantaneous power pulses as needed. Offers great solutions to Hold Up, Energy Harvesting, and Pulse Power Applications.

FEATURES

- Cap Values from 1F – 3500F
- High pulse power capability
- Low ESR
- Low Leakage Current

APPLICATIONS

- Camera Flash Systems
- Energy Harvesting
- GSM/GSR Pulse Applications
- UPS/Industrial
- Wireless Alarms
- Remote Metering
- Scanners
- Toys and Games

HOW TO ORDER

SCC T	R T	12 T	B T	105 T	S T	R T	B T	T T
Series SuperCap Cylindrical	Diameter Q=6.3mm R = 8mm S = 10mm T = 12.5mm U = 16mm V = 18mm W = 22mm X = 30mm Y = 35mm Z = 60mm	Case Length Two digits Represent case Length in mm, With the exception Of the following: 1A = 120mm 1E = 138mm 1F = 165mm	Voltage Code B = 2.7V	Capacitance Code 105 = 1F 106 = 10F 107 = 100F 108 = 1000F	Tolerance M = ±20% S = +30%/-10% V = +25%/-5%	Lead Format R = Radial S = Solder Pin C = Cylindrical	Package B = Bulk	Custom Code __ = No Change XX = Per Spec

QUALITY INSPECTION

Parts are tested for Life Cycle, high temperature load life, temperature characteristics, vibration resistance, and humidity characteristics. See page 2 for more information.

TERMINATION

These supercapacitors are compatible with hand soldering, as well as reflow and wave soldering processes, so long as appropriate precautions are followed. See page 5 for more information

OPERATING TEMPERATURE

-40°C to +65°C @ 2.7V
-40°C to +85°C @ 2.3V



SCC Series Supercapacitors

High Capacitance Cylindrical Supercapacitors



RATINGS & PART NUMBER REFERENCE

AVX Part Number	Diameter (mm)	Length (mm)	Capacitance (F)	Capacitance Tolerance	Rated Voltage (V)	Rated Temperature (°C)	DCL Max @ 72 Hrs (uA)	ESR Max @ 1000 KHz (mΩ)	ESR Max @ DC (mΩ)	Peak Current (A)	Power Density (W/kg)	Max Energy (Wh)	Energy Density (Wh/kg)
Radial Lead													
SCCQ12B105SRB	6.3	12	1	30%/-10%	2.7	65 *	6	200	500	0.9	2261	0.001	1.4
SCCR12B105SRB	8	12	1	30%/-10%	2.7	65 *	6	150	500	0.9	2039	0.001	1.2
SCCR16B205SRB	8	16	2	30%/-10%	2.7	65 *	10	100	360	1.57	2240	0.002	1.9
SCCR20B335SRB	8	20	3.3	30%/-10%	2.7	65 *	12	95	290	2.32	2271	0.0033	2.7
SCCS20B505SRB	10	20	5	30%/-10%	2.7	65 *	15	70	180	4.09	2278	0.0051	2.4
SCCS25B705SRB	10	25	7	30%/-10%	2.7	65 *	20	60	150	4.61	3756	0.0071	2.8
SCCS30B106SRB	10	30	10	30%/-10%	2.7	65 *	30	40	75	9	3481	0.0101	3.3
SCCT20B106SRB	12.5	20	10	30%/-10%	2.7	65 *	30	50	75	9	3756	0.0101	3
SCCT30B156SRB	12.5	30	15	30%/-10%	2.7	65 *	50	35	80	9.2	2485	0.0152	3.5
SCCU25B256MRB	16	25	25	20%/-20%	2.7	65 *	60	27	50	15	2441	0.0253	3.5
SCCU30B356MRB	16	30	35	20%/-20%	2.7	65 *	70	20	40	18.4	2644	0.0356	3.7
SCCV40B506MRB	18	40	50	20%/-20%	2.7	65 *	75	18	20	40.5	3450	0.0506	4
SCCV60B107MRB	18	60	100	20%/-20%	2.7	65 *	260	15	18	53.6	2329	0.1013	4.9
Solder Pin Lead													
SCCW45B107VSB	22	45	100	+25%/-5%	2.7	65 *	260	8	12	61.3	3727	0.1013	5.2
SCCX50B207VSB	30	50	200	+25%/-5%	2.7	65 *	600	6	9	96.4	2468	0.2025	5.1
SCCY62B307VSB	35	62	300	+25%/-5%	2.7	65 *	650	6	9	103.8	2131	0.3032	5.2
SCCY68B407VSB	35	68	400	+25%/-5%	2.7	65 *	1000	4	5	173.5	2639	0.4045	5.6
Cylindrical Lug Lead													
SCCY60B367VCB	35	60	360	+25%/-5%	2.7	65 *	1000	2	2.4	260.7	4288	0.3645	4.3
SCCZ51B657VCB	60	51	650	+25%/-5%	2.7	65 *	1800	0.56	0.78	582.2	4876	0.6581	2.9
SCCZ74B128VCB	60	74	1200	+25%/-5%	2.7	65 *	2700	0.38	0.54	983	4737	1.215	3.6
SCCZ1AB208VCB	60	120	2000	+25%/-5%	2.7	65 *	4200	0.26	0.35	1588	5375	2.025	4.4
SCCZ1EB308VCB	60	138	3000	+25%/-5%	2.7	65 *	5200	0.2	0.29	2165	5292	3.037	5.3
SCCZ1FB358VCB	60	165	3500	+25%/-5%	2.7	65 *	5800	0.16	0.29	2344	4567	3.5437	5.4

* With Voltage Derating to 2.3V per Cell Temp can be rated to 85°C

QUALIFICATION TEST SUMMARY

Test	Test Method	Parameter	Limits
Life Cycle	Capacitors are cycled between specified voltage and half-rated voltage under constant current at +25°C for 50,000 cycles	Capacitance Change ESR Appearance	≤30% of initial value ≤2 times initial value No remarkable defects
High Temperature Load Life	Temperature: 60 ± 2°C Voltage: 2.7V Test Duration: 1,000 +48/-0 hours	Capacitance Change ESR Appearance	≤30% of initial value ≤2 times initial value No remarkable defects
Temperature Characteristics	Storage Duration: 12 hours No Load Temperature: -40°C, +25°C, +65°C	Capacitance Change ESR Appearance	≤30% of initial value ≤2 times initial value No remarkable defects
Vibration Resistance	Amplitude: 1.5mm Frequency: 10 ~ 55Hz Direction: X, Y, Z (Each for 2 hours) Test Duration: 6 hours	Capacitance Change ESR Appearance	≤30% of initial value ≤2 times initial value No remarkable defects
Humidity	Voltage: 2.7V RH: 90~95% Test Duration: 240 hours Temperature: 40 ± 2°C	Capacitance Change ESR Appearance	≤30% of initial value ≤2 times initial value No remarkable defects

SCC Series Supercapacitors

High Capacitance Cylindrical Supercapacitors



QUALITY AND RELIABILITY

Capacitance Change v. Temperature

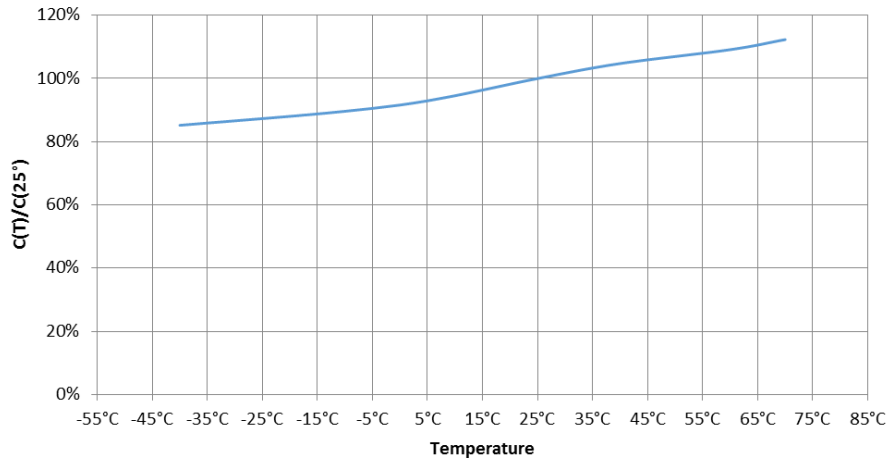

Leakage Current Change v. Temperature

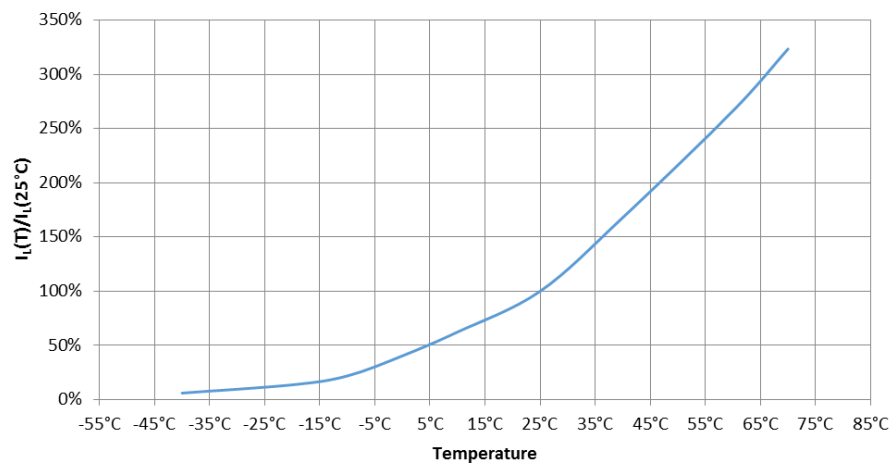

ESR Change v. Temperature

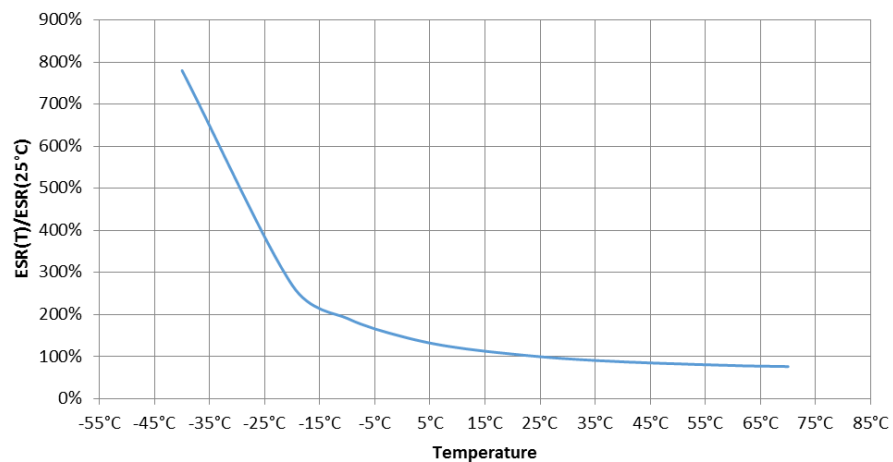

SCC Series Supercapacitors

High Capacitance Cylindrical Supercapacitors



MECHANICAL SPECIFICATIONS

Radial Lead Type 1F – 100F

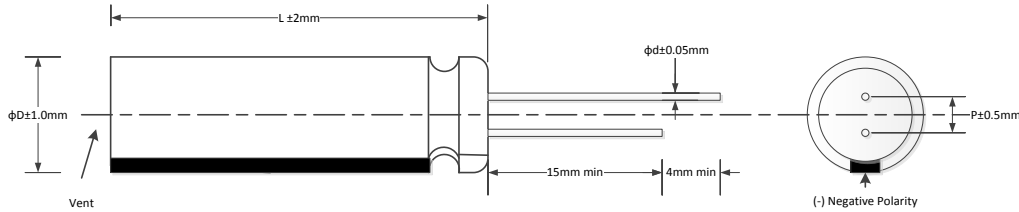

D	P	d
6.3	2.3	0.6
8	3.5	0.6
10	5.5	0.6
12.5	5.5	0.6
16	8	0.8
18	8	0.8

Solder Pin Type 2-pin 100F, 200F parts

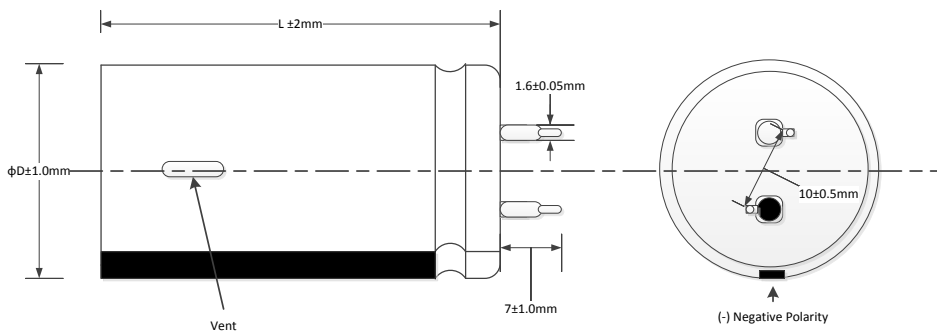

Solder Pin Type 4-pin 300F, 400F parts

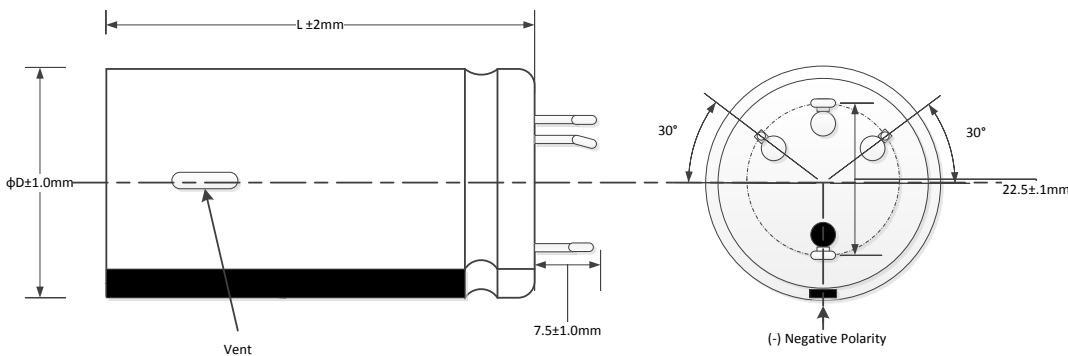

Cylindrical Type 360F – 3500F

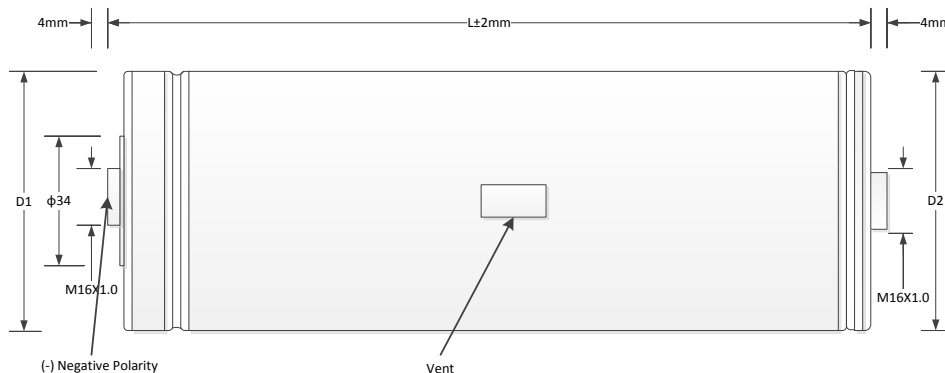

SCC Series Supercapacitors

High Capacitance Cylindrical Supercapacitors



SOLDERING RECOMMENDATIONS

When soldering supercapacitors to a PCB, the temperature & time that the body of the supercapacitor sees during soldering can have a negative effect on performance. We advise following these guidelines:

- Do not immerse the supercapacitors in solder. Only the leads should come in contact with the solder.
- Ensure that the body of the supercapacitor is never in contact with the molten solder, the PCB or other components during soldering.
- Excessive temperatures or excessive temperature cycling during soldering may cause the safety vent to burst or the case to shrink or crack, potentially damaging the PCB or other components, and significantly reduce the life of the capacitor.

HAND SOLDERING

Keep distance between the supercapacitor body and the tip of the soldering iron and the tip should never touch the body of the capacitor. Contact between supercapacitor body and soldering iron will cause extensive damage to the supercapacitor, and change its electrical properties. It is recommended that the soldering iron temperature should be less than 350°C, and contact time should be limited to less than 4 seconds. Too much exposure to terminal heat during soldering can cause heat to transfer to the body of the supercapacitor, potentially damaging the electrical properties of the supercapacitor.

WAVE SOLDERING

Only use wave soldering on Radial type supercapacitors. The PCB should be preheated only from the bottom and for less than 60 seconds, with temperature at, or below, 100°C on the top side of the board for PCBs equal to or greater than 0.8 mm thick.

Solder Temperature (°C)	Suggested Solder Time (s)	Maximum Solder Time (s)
220	7	9
240	7	9
250	5	7
260	3	5

REFLOW SOLDERING

Infrared or conveyor over reflow techniques can be used on these supercapacitors. Do not use a traditional reflow oven without clear rated reflow temperature for supercapacitors.

SCC Series Supercapacitors

High Capacitance Cylindrical Supercapacitors



TEST METHODS

IEC Capacitance Test Method

- Capacitance is measured using a Keithley 2400 or 2602 Meter
- Procedure
 - Charge Capacitor to Rated Voltage at room temperature
 - Disconnect parts from voltage to remove charging effects
 - Discharge cells with a constant current I determined by $4 * C * V_R$
 - Noting V_1, t_1, V_2, t_2 and performing the calculation for C

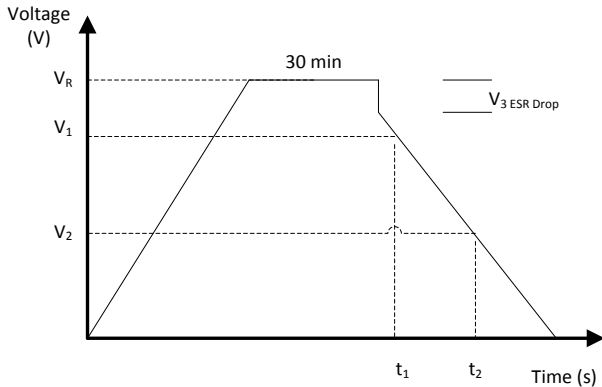

I – Discharge Current, $4 * C * V_R$
 V_R – Rated Voltage
 V_1 – Initial Test Voltage, 80% of V_R
 V_2 – Final Test Voltage, 40% of V_R
 t_1 – Initial Test time
 t_2 – Final Test time

$$C = I * (t_2 - t_1) / (V_1 - V_2)$$

DCL Measurement @ 25°C

- DCL is measured using a Multimeter with high internal impedance across a resistor
 - Charge Capacitor to Rated Voltage at room temperature for 72 Hours
 - Disconnect parts from Voltage by opening switch 1 (Stabilize for 10 Min)
 - Measure Voltage across a known Valued Resistor (1K Ohm)
 - Calculate $DCL = V/R$

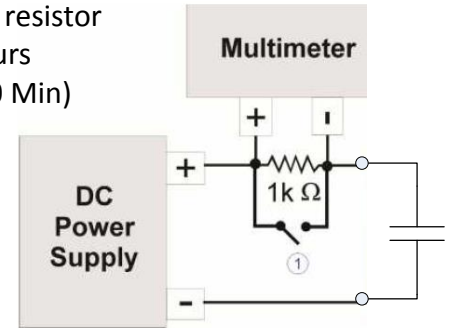

Initial ESR Measurement @ 25°C

- Using an Agilent 4263B LCR Meter and a Kelvin connection
 - Measure at frequency of 1000 Hz
 - Measurement Voltage of 10mV

DC ESR Measurement

- Six steps capacity and ESR_{DC} Test Method is used as illustrated in the figure right.
- Tests are carried out by charging and discharging the capacitor for two cycles at rated voltage and half rated voltage

$$C = (C_{DC1} + C_{DC2}) / 2$$

$$ESR_{DC} = (ESR_{DC1} + ESR_{DC2}) / 2$$

Where:

$$C_{DC1} = I_2 * (t_5 - t_4) / (V_3 - V_4)$$

$$C_{DC2} = I_2 * (t_{11} - t_{10}) / (V_9 - V_{10})$$

$$ESR_{DC1} = (V_5 - V_4) / I_2$$

$$ESR_{DC2} = (V_{11} - V_{10}) / I_2$$

$$I_1 = I_2 = 75mA/F$$

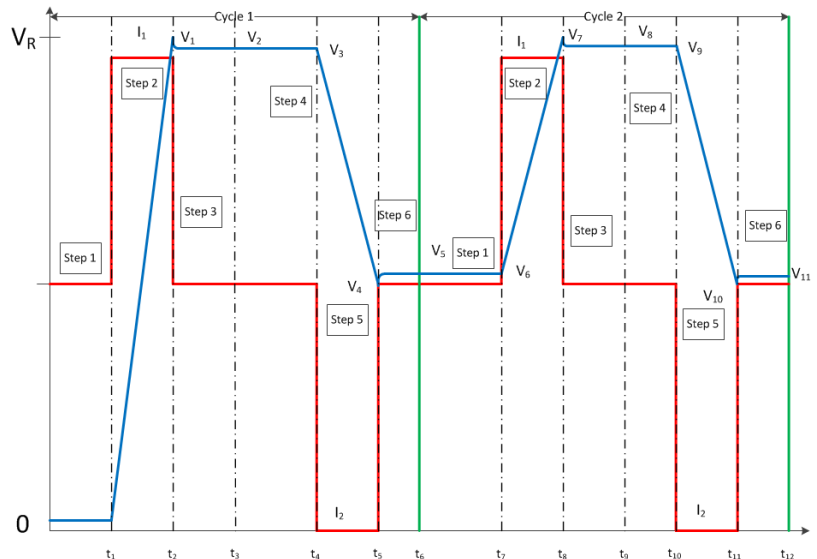

SCC Series Supercapacitors

High Capacitance Cylindrical Supercapacitors



TEST METHODS (continued)

Maximum Operating Current

- This is the maximum current when capacitor temperature rise of the capacitor during its operation is less than 15°C

Maximum Peak Current

- This is the maximum current in less than 1 sec

Watt Density

- Watt Density = $(0.12 \cdot V^2 / R_{DC}) / \text{mass}$

Energy density

- Energy density = $(\frac{1}{2} CV^2) / (3600 \cdot \text{mass})$

Polarity / Reverse Voltage

In principal the positive and negative electrodes of the super-capacitors are symmetrical and in theory they should not have a polarity but for product consistency and for optimum performance the negative polarity is marked because the capacitors do not discharge completely when in use. It is recommended that the polarity should be used as marked. If the polarity is reversed the circuit will not have a catastrophic failure but the circuit will see a much higher leakage current for a short duration of time and the life time of the super-capacitors will be reduced.

Life time and Temperature Performance

The life of a supercapacitor is impacted by a combination of operating voltage and the operating temperature according to the following equation:

$$\text{time to failure, } t \propto V^n \cdot \exp(-Q / k \cdot T) \dots\dots\dots(1)$$

where V is the voltage of operation, Q is the activation energy in electron volts (eV), k is the Boltzmann's constant in eV and T is the operating temperature in °K (where K is in degrees Kelvin). Typical values for the voltage exponent, n, is between 2.5 - 3.5, and Q is between 1.0 - 1.2 eV in the normal operating temperature range of 40° to 65°C.

The industry standard for super-capacitor end of life is when the equivalent series resistance, ESR, increases to 200% of the original value and the capacitance drops by 30%. Typically a super-capacitance shows an initial change in the ESR value and then levels off. If the capacitors are exposed to excessive temperatures the ESR will show a continuous degradation. In the extreme case, if the temperatures or voltages are substantially higher, than the rated voltage, this will lead to cell leakage or gas leakage and the product will show a faster change in the ESR which may increase to many times the original value.

Calculated values are shown in the charts on the following page .

Life time and Temperature Performance

Expected Lifetime at Various Voltages
SCC series 2.7V Rated

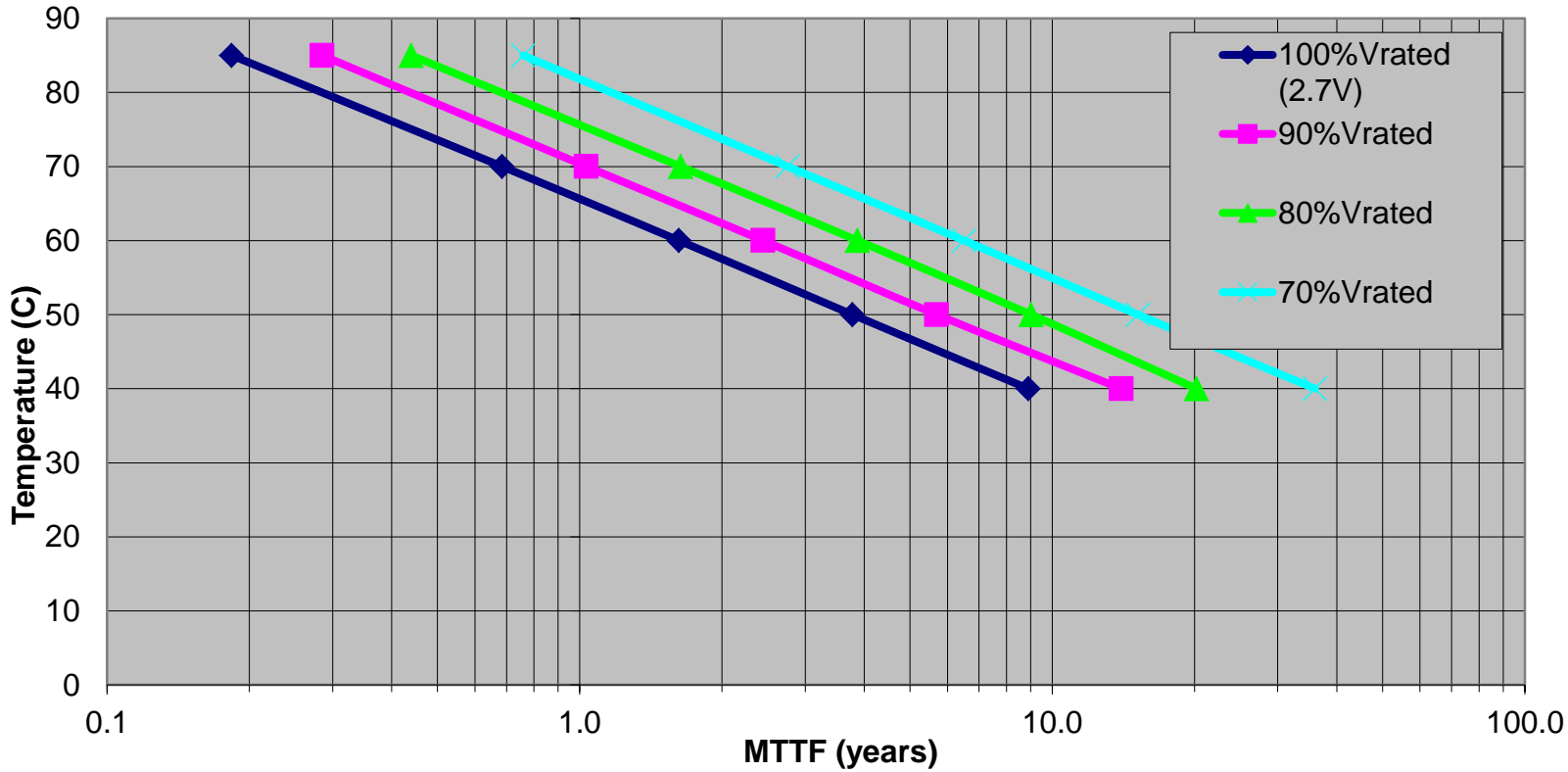

Expected Lifetime at Various Voltages
SCC series, 2.3V Rated

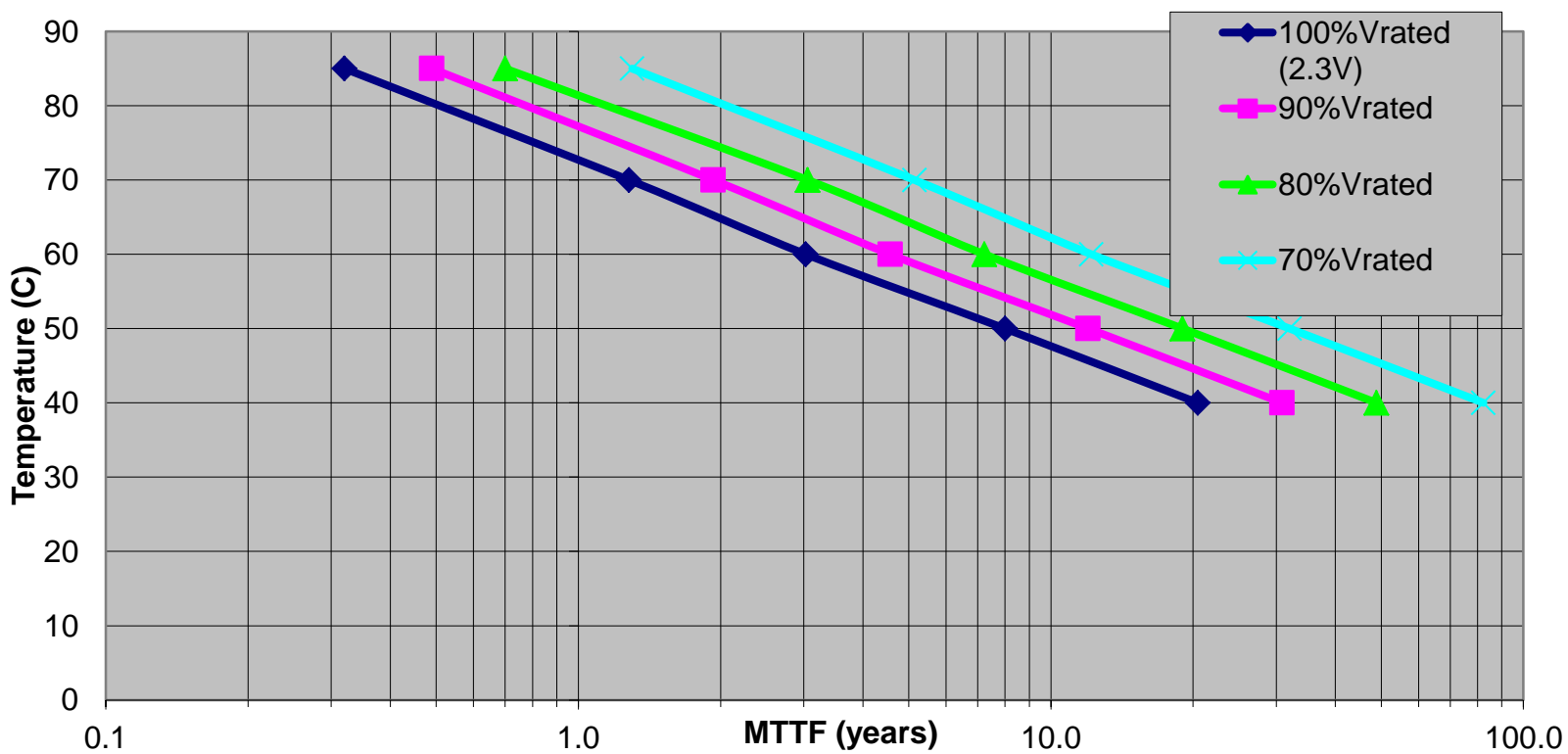

SCC Series Supercapacitors

High Capacitance Cylindrical Supercapacitors



SAFETY RECOMMENDATIONS

Warnings

- To Avoid Short Circuit, after usage or test, Super Capacitor voltage needs to discharge to $\leq 0.1V$
- Do not Apply Overvoltage, Reverse Charge, Burn or Heat Higher than $150^{\circ}C$, explosion-proof valve may break open
- Do not Press, Damage or disassemble the Super Capacitor, housing could heat to high temperature causing Burns
- If you observe Overheating or Burning Smell from the capacitor disconnect Power immediately, and do not touch

Emergency Applications

- If Housing is Leaking:
 - Skin Contact: Use soap and water thoroughly to wash the area of the skin
 - Eye Contact: Flush with flowing water or saline, and immediately seek medical treatment
 - Ingestion: Immediately wash with water and seek medical treatment

Transportation

Not subjected to US DOT or IATA regulations

UN3499, <0.3Wh, Non-Hazardous Goods

International shipping description – “Electronic Products – Capacitor”

Regulatory

- UL810a
- RoHS Compliant
- Reach Compliant / Halogen Free

Storage

- Capacitors may be stored within the operating temperature range of the capacitor
- Lower storage temperature is preferred as it extends the shelf life of the capacitor
- Do Not Store the Super Capacitors in the following Environments
 - High Temperature / High Humidity environments $>70^{\circ}C$ / 40% RH
 - Direct Sunlight
 - In direct contact with water, salt oil or other chemicals
 - In direct contact with corrosive materials, acids, alkalis, or toxic gases
 - Dusty environment
 - In environment with shock and vibration conditions